



2024

POIDS LOURDS - REMORQUES - UTILITAIRES
VEICOLI INDUSTRIALI - RIMORCHI - FURGONI
VEHÍCULOS INDUSTRIALES - SEMIRREMOLQUES



www.vignal-group.com



Photos à 360°
Foto a 360°
Fotos 360°



Fiches produits détaillées
Schede prodotto dettagliate
Fichas de producto detalladas



Centre de téléchargement
Centro download
Centro de descargas



Aide questions produits
Domande sui prodotti
Ayuda productos

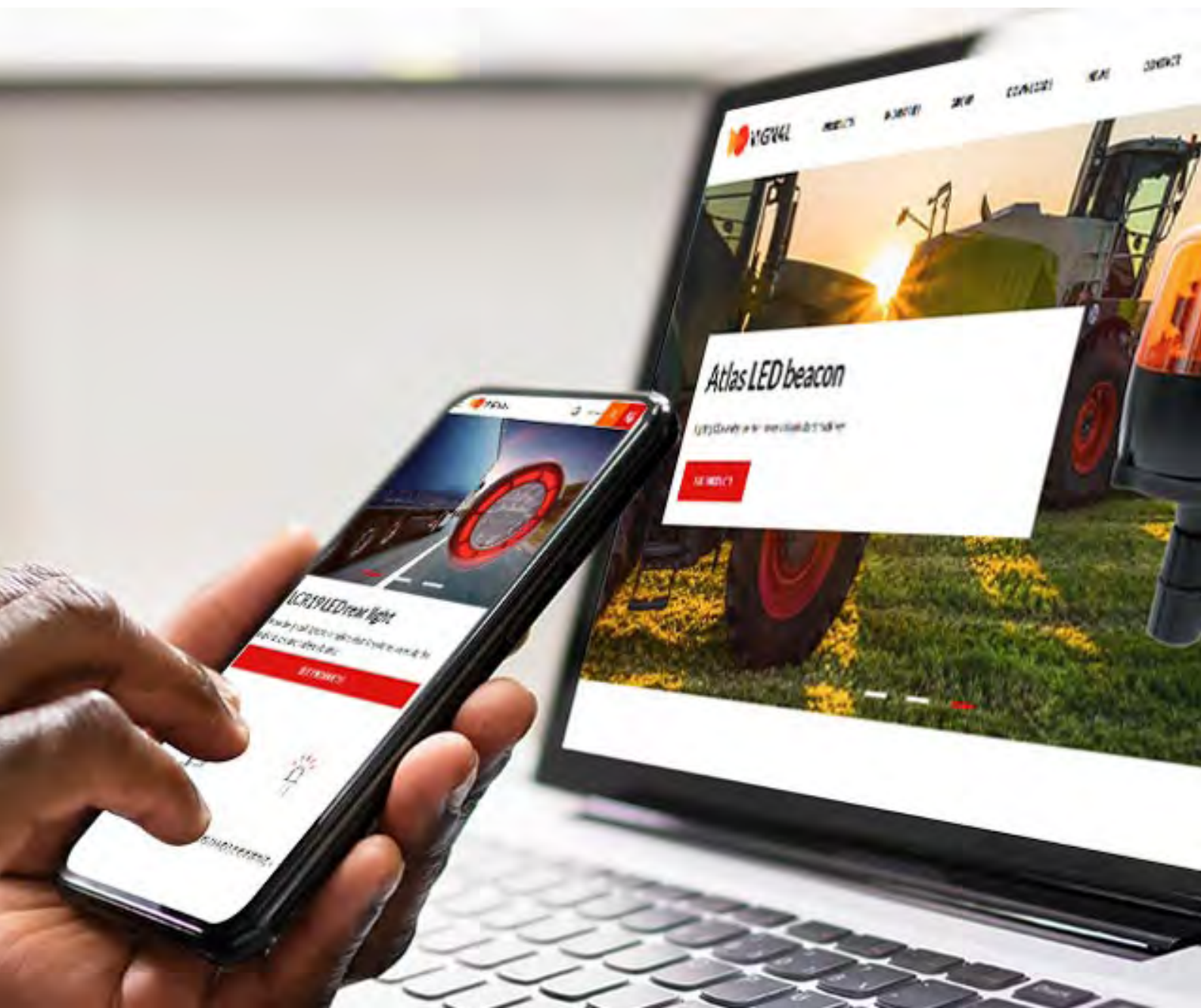

ALMAJDOUIE.....	8
ASCA.....	10
BENALU GROUP	14
CHEREAU	17
DAF	20
DE BUF	25
FELDBINDER	27
FIAT	29
FORD	30
FRUEHAUF	31
GROSSE EQUIPEMENT	33
IVECO	34
LAMBERET.....	44
LECAPITAINE.....	48
LECIÑENA.....	49
MAGYAR.....	51
MAN	52
MERCEDES / DAIMLER	55
NISSAN	58
OMEPS.....	59
OPEL.....	61
PEUGEOT CITROËN	62
RENAULT TRUCKS.....	63
SCANIA	91
SCHMITZ	93
SOR IBERICA	95
TROUILLET.....	97
UD TRUCKS.....	98
VAK OY.....	99
VOLKSWAGEN	100
VOLVO.....	101

SIGNALISATION - SEGNALAZIONE - SEÑALIZACIÓN

Feux arriere - Fanali posteriori - Pilotos traseros.....	111
Eclaireurs de plaque - Luce targa - Iluminación de placa	149
Feux clignotants - Luci intermittenti - Pilotos intermitentes	153
Feux de position - Luci di posizione - Pilotos de posición	159
Feux de gabarits - Luci d'ingombro - Luces de anchura.....	173
Signalisation passive - Segnaletica passiva - Señalización.....	179

ECLAIRAGE - ILLUMINAZIONE - ILUMINACIÓN

Phares de recul - Fari retromarcia - Faros marcha atrás	186
Phares de travail - Fari da lavoro - Faros de trabajo	185
Éclairage de sécurité - Luci di segnalazione - Faros de advertancia.....	201
Phares de conduite - Proiettori - Proyectores	202
Feux auxiliaire - Fari ausiliari - Iluminación auxiliar.....	209
Éclairage intérieur - Illuminazione interna - Iluminación interior	214

PRODUITS DE SÉCURITÉ - PRODOTTI DI SICUREZZA - PRODUCTOS DE SEGURIDAD

Gyrophares - Girofari - Luces rotativas.....	218
Rampes lumineuses - Barre di segnalazione - Puentes luminosos	231
Triflash.....	233
Feux de pénétration - Luci direzionali - Luces direccionales	237
Alarmes sonores de recul - Cicalino di retromarcia - Alarmas sonoras de marcha atrás	240
Systèmes caméras - Telecamere - Sistemas de cámara	243
Coffres porte extincteur - Cassonetti porta estintore - Porta extintores	251

ÉLECTRIQUE-ÉLECTRONIQUE - ELETTRICO-ELETTRONICO - ELÉCTRICOS-ELECTRÓNICOS

Prises et câbles spiralés - Spine e spirali - Enchufes y espirales	253
Connecteurs - Connettori - Conectores	259
Faisceaux - Cablaggi - Cableados.....	263
Systèmes câblage et feux - Kit cablaggi e fanali - Sistemas cableados e iluminación.....	272

RECHERCHE PRODUITS - RICERCA PRODOTTI - BÚSQUEDA PRODUCTOS

Par liste de correspondance - Per codice costruttore- Por referencias cruzadas.....	276
Par référence - Per riferimento - Por referencia.....	280
Par no. d'homologation - Per no. di omologazione - Por no. de homologación.....	282
Par photo - Per foto - Por foto.....	285

Vignal Group, le spécialiste de l'éclairage et de la sécurité pour véhicules industriels et commerciaux.

Vignal Group, lo specialista in illuminazione e sicurezza per veicoli industriali e commerciali.

Vignal Group, el especialista en iluminación y seguridad para vehículos industriales y comerciales.



+20 ans de politique RSE
+20 anni di politica CSR
+20 años de política de RSE



Certifié - Certificato - Certificado
ISO 14001 - ISO 9001
IATF 16949 - CCC - Certifer



Une croissance constante
Una crescita costante
Un crecimiento constante



10% des personnes en R&D
10% delle persone in R&S
10% de personas en I+D



Une solution globale... Una soluzione globale... Una solución global...



...pour vos véhicules. ...per i vostri veicoli. ... para sus vehículos.



Des marques validées par les constructeurs.

Marchi convalidati dai OE.

Marcas aprobadas OE.



Notre philosophie est de concevoir globalement et de produire localement. Nos sites sont présents sur trois continents pour vous offrir la meilleure flexibilité pour le meilleur service possible.

La nostra filosofia è quella di avere un design globale per una produzione locale. Nostri stabilimenti sono situati su tre continenti per offrirvi maggiore flessibilità per un servizio migliore.

Nuestra filosofía es diseñar globalmente y producir localmente. Nuestros sitios están presentes en tres continentes para ofrecerle la mejor flexibilidad y servicio posibles.



Vignal a fait du développement durable l'un de ses axes stratégiques majeurs.

Vignal ha fatto dello sviluppo sostenibile uno dei suoi principali assi strategici.

Vignal ha hecho del desarrollo sostenible uno de sus principales ejes estratégicos.



Camions et poids lourds - Camion - Camiones



Semi-remorques - Semirimorchio - Semiremolques



Utilitaires - Furgoni - Industrial



Produits d'origine constructeurs

Prodotti originali costruttori

Productos originales constructores



AMP 1.5-7P-M

Type connecteur - Nb pins - Mâle ou Femelle
 Tipo di connettore - Num pin - Maschio o Femmina
 Tipo de conector - Num pines - macho o hembra



Faisceau p. 266
 Cablaggio p. 266
 Cableado p. 266



Flashez le QR code pour plus d'infos
 Scansiona il codice QR per maggiori informazioni
 Escanee el código QR para obtener más info



Pièces détachées
 Componenti
 Componentes

08/2020 ->

Dates d'application
 Date di applicazione
 Fechas de aplicación



p. 154 Numéro page produit standard
 Numero di pagina del prodotto standard
 Número de página producto estándar

DETAIL CONNECTEUR 1.3	Identifier les positions des connecteurs	FUNCTION
1	WIRING	FUNCTION
2	POSITION	
3	SEAL	
4	INDICATEUR DE DIRECTION	
5	STOP	
6	INDICATED	
7	NOT USED	

Pinning connecteurs sur notre site web
 Pinning dei connettori sul nostro sito web
 Pinning conectores en nuestro sitio web

Ce catalogue présente une sélection d'application première monte constructeurs pour les poids lourds, camions, semi-remorques et utilitaires. Pour les autres applications véhicules (agricole, construction, cars et bus, road service...), veuillez vous référer au site web et à nos autres documentations.

Questo catalogo presenta una selezione di applicazioni OEM per mezzi pesanti, camion, semirimorchi e veicoli commerciali. Per altre applicazioni su veicoli (agricoli, edili, pullman e autobus, servizi stradali, ecc.), si rimanda al sito web e alla nostra documentazione.

Este catálogo presenta una selección de aplicaciones OEM para camiones, semirremolques y vehículos comerciales. Para otras aplicaciones de vehículos (agrícolas, construcción, autocares y autobuses, servicios de carretera, etc.), consulte el sitio web y el resto de nuestra documentación.

ALMAJDOUIE

LC12T LED p. 112

LED

 24V



161000



161190



gauche - sinistra - izquierda



AMP 1.5-7P-M

arrière
connettore posteriore
conector trasero



161010



161180



droit - destra - derecha



D11868

AMP 1.5-7P-F

LC8T p. 133



156040



gauche - sinistra - izquierda



AMP 1.5-7P-M

arrière
connettore posteriore
conector trasero



156050



droit - destra - derecha



D11868

AMP 1.5-7P-F



056700



gauche - sinistra - izquierda



056710



droit - destra - derecha

LPL18 p. 150

LED

 12/24V



199040

SS-2P-M



D13880

SS-2P-F

SMD04 p. 165

LED

 24V



104260

1500 mm 

CLICK-IN

FA3LED p. 174

LED

 12/24V



D14427

1500 mm

gauche - sinistra - izquierda

CLICK-IN



D14428

1500 mm

droit - destra - derecha

CLICK-IN

LC12T LED

 p. 112

LED

 24V



161000

gauche - sinistra - izquierda



AMP 1.5-7P-M

arrière
connettore posteriore
conector trasero



161010

droit - destra - derecha



D11868

AMP 1.5-7P-F

LC8T

 p. 133



156040

gauche - sinistra - izquierda



AMP 1.5-7P-M

arrière
connettore posteriore
conector trasero



156050

droit - destra - derecha



156060

gauche - sinistra - izquierda



D11868

AMP 1.5-7P-F



056700

gauche - sinistra - izquierda



056710

droit - destra - derecha



LC5TDX ⓘ p. 141



153660

gauche - sinistra - izquierda



AMP 1.5-7P-M
arrière
connettore posteriore
conector trasero



153670

droit - destra - derecha



D11868

AMP 1.5-7P-F



053700

gauche - sinistra - izquierda



053710

droit - destra - derecha



LC5T ⓘ p. 140



153000

gauche - sinistra - izquierda



AMP 1.5-7P-M
arrière
connettore posteriore
conector trasero



153010

droit - destra - derecha



153020

gauche - sinistra - izquierda



D11868

AMP 1.5-7P-F



053700

gauche - sinistra - izquierda



053710

droit - destra - derecha



EPP96 ⓘ p. 152



D10502

410 mm

CLICK-IN

EPP96 LED i p. 151

LED

⚡ 24V



D13609 400 mm
CLICK-IN

FE04 i p. 160

LED

⚡ 24V



104310 5000 mm



D10132 200 mm

SMD98 i p. 161

LED

⚡ 24V



D11399 1500 mm ^K
CLICK-IN



001716

SMD04 i p. 160

LED

⚡ 24V



104140 1500 mm ^K
CLICK-IN



104100 1500 mm ^K
CLICK-IN



104260 1500 mm ^K
CLICK-IN



104220 1500 mm ^K
CLICK-IN

DXLC8 p. 175



D13034

gauche - sinistra - izquierda

CLICK-IN



D13035

droit - destra - derecha

CLICK-IN

DX p. 176



D12428

W5W

1400 mm

CLICK-IN

FA3LED p. 174

LED



12/24V



D14427

1500 mm

gauche - sinistra - izquierda

CLICK-IN



D14428

1500 mm

droit - destra - derecha

CLICK-IN

MDJ p. 265



175020

BENALU GROUP

LC12 LED

 p.112

LED

 24V



161000

gauche - sinistra - izquierda



AMP 1.5-7P-M
arrière
connettore posteriore
conector trasero



161010

droit - destra - derecha



D11868

AMP 1.5-7P-F

NEW



D14781

gauche - sinistra - izquierda

NEW



D14782

droit - destra - derecha

SS-2P-F

LCR19

 p.114

LED

 24V

NEW



213010

AMP MCP-4P-M

NEW



213090

AMP MCP-4P-M

NEW



213150

AMP MCP-4P-M

SMC
Position lateral clignotant
Posizione laterale lampeggiante
Posición lateral e intermitente

POS
Position
Posizione
Posición

RI
Resistance integree (contrôle défaillance indicateur)
Resistenza integrata (controllo errore intermittente)
Resistencia integrada (control de fallo del intermitente)

Position Glowing - Stop - Clignotant
Posizione Glowing - Stop - Indicatore
Posición Glowing - Stop - Intermitente

Position Glowing - Stop - Clignotant
Posizione Glowing - Stop - Indicatore
Posición Glowing - Stop - Intermitente

Recul - Brouillard
Retromarcia - Retronebbia
Marcha atrás - Antiniebla

RI

SMC

POS



R23



LC8T p. 133



156040

gauche - sinistra - izquierda



AMP 1.5-7P-M

arrière
connettore posteriore
conector trasero



156050

droit - destra - derecha



D11868

AMP 1.5-7P-F



056700

gauche - sinistra - izquierda



056710

droit - destra - derecha



001830



LPL18 p. 150

LED

NEW



12/24V



199040

SS-2P-M



D13880

SS-2P-F

SMD04 p. 160

LED



24V



104140

1500 mm 

CLICK-IN



104090

500 mm 

104100

1500 mm 

CLICK-IN



104260

1500 mm 

CLICK-IN



104640

300 mm 

104650

1000 mm 

bride rallongée - supporto esteso - soporte extendido

CLICK-IN

BENALU GROUP

SMD98

 p. 161

LED



24V



D11399 1500 mm

K

CLICK-IN



001716

DXLC8

 p. 175



D12712

gauche - sinistra - izquierda

POS-2P-F



D12711

droit - destra - derecha

POS-2P-F

ASR

 p. 241



12/24V

Multi-Frequency



D13810

1500 mm

97 dB



CLICK-IN

Standard



630120

87 dB



SL 1000

 p. 188

LED



12/24V

NEW



D14850



BL15-CTL15

i p. 120

LED

24V



Exemple de montage - Esempio di montaggio - Ejemplo de montaje



DT04-4P-M



164000
(OE 21153)



DT04-4P-M



DTM04-4P-M



164010
(OE 21154)

Pour raccordement sur feu BL15
Per collegamento su fanale BL15
Para conectar sobre piloto BL15



165020
(OE 21781)

gauche - sinistra - izquierda



DT04-4P-M



DTM06-4S-4P-F



165030
(OE 21155)

droit - destra - derecha



D14436 DT06-4S-4P-F



D14437 DTM06-4S-4P-F



D14435 DTM04-4P-M

LC8T

i p. 133



156040

T FPL

156060

T FPL EPP

gauche - sinistra - izquierda

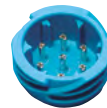

AMP 1.5-7P-M

arrière
connettore posteriore
conector trasero



156050

T FPL

156070

T FPL EPP

droit - destra - derecha



D11868 AMP 1.5-7P-F



056700

T

gauche - sinistra - izquierda



056710

T

droit - destra - derecha



156550

gauche - sinistra - izquierda



AMP 1.5-7P-M

arrière
connettore posteriore
conector trasero



156540

droit - destra - derecha



D11868

AMP 1.5-7P-F

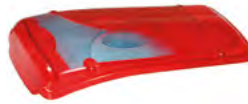

056000

gauche - sinistra - izquierda



056010

droit - destra - derecha



001846

NEW



SS-2P-M

153160

gauche - sinistra - izquierda



AMP 1.5-7P-M

arrière
connettore posteriore
conector trasero

NEW



SS-2P-M

153170

droit - destra - derecha



153020

gauche - sinistra - izquierda



153010

droit - destra - derecha



D11868

AMP 1.5-7P-F



053700

gauche - sinistra - izquierda



053710

droit - destra - derecha



EPP96 p. 150



196020 R10W

SL 1000 p. 186

LED

 12/24V

 R23



D14857 DT-2P-M



Feu homologué recul - Luce di retromarcia omologati
- Piloto marcha atrás homologado



D14170 DT-2P-F

04/2012 ->



155100
(OE 1875577)   
gauche - sinistra - izquierda



HDSCS-8P-M
latéral
connettere laterale
conector lateral





155110
(OE 1875576)  
droit - destra - derecha





Entraxe : 160 mm
Distanza tra le viti posteriori : 160 mm
Distancia entre tornillos : 160 mm



155120
(OE 1875578)   
droit - destra - derecha

04/2012 ->



155130
(OE 1875580)   
gauche - sinistra - izquierda



HDSCS-8P-M
arrière
connettere posteriore
conector trasero



155140
(OE 1875579)  
droit - destra - derecha



155150
(OE 1875581)   
droit - destra - derecha



D13878 **HDSCS-8P-F**



055020
(OE 1914690) 
gauche - sinistra - izquierda



055030
(OE 1914691) 
droit - destra - derecha



001830
(OE 1973239) 
Alarme sonore de recul
Cicalino di retromarcia
Alarma sonora de marcha atrás

1995 -> 04/ 2012



1995 ->2001



167640
(OE 1284211)  

168020
(OE 1304789)   

gauche - sinistra - izquierda



DAF
arrière
connettore posteriore
conector trasero



167630
(OE 1284212) 

168010
(OE 1304788)  

droit - destra - derecha



168890
(OE 1660967)   

droit - destra - derecha

2001 -> 04/2012



169160
(OE 1625985)   

gauche - sinistra - izquierda



AMP 1.5-7P-M
latéral
connettore laterale
conector lateral



169170
(OE 1625986)  

droit - destra - derecha



169380
(OE 1660968)   

droit - destra - derecha



D11868 **AMP 1.5-7P-F**



067500
(OE 1272653) 

gauche - sinistra - izquierda



067500
(OE 1272653) 

droit - destra - derecha



D12953
(OE 1519358) 

Alarme sonore de recul
Cicalino di retromarcia
Alarma sonora de marcha atrás

1993 ->



109010
(OE 1814096/1815754)

ICDL10

 p.156

01/2013 ->



117000
(OE 1846491)

gauche - sinistra - izquierda



117010
(OE 1846492)

droit - destra - derecha



001619

75 - 85 - XF - CF

FPL93

 p.168



193020
(OE 1329718)

K

JPT-2P-M

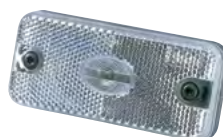

193200
(OE 1653605)

K

JPT-2P-M



001726
(OE 1608352)



D13876

JPT-2P-F

LF

LC5

 p.137

2001 ->



152170
(OE 1401713)

K

EPP

gauche - sinistra - izquierda



AMP 1.5-7P-M

arrière
connettere posteriore
conector trasero



152180
(OE 1401731)

K

droit - destra - derecha



D11868 AMP 1.5-7P-F



052500
(OE 1451482)

K

gauche - sinistra - izquierda



052500
(OE 1451482)

K

droit - destra - derecha

LF

FE95

 p. 162



195010
(OE 1403887)

gauche - sinistra - izquierda



195010
(OE 1403887)

droit - destra - derecha

ICDL94

 p. 157



119550
(OE 1626101)





001616
(OE 1626102)



D13877 

FE02

 p. 162



102200
Clippé - fissaggio con clip -
fijación con clip







001726
(OE 1608352)



D13876 

FPL93

 p. 168



193020
(OE 1329718)







001726
(OE 1608352)



D13876 

EPP98

 p. 152



196010
(OE 0867930)







D13876 

1993 -> 1995





168100
(OE 1626319/1284213)   
gauche - sinistra - izquierda



DIN
arrière
connettore posteriore
conector trasero



168390
(OE 1626320/1284214)   
droit - destra - derecha



067500
(OE 1272653) 
gauche - sinistra - izquierda



067500
(OE 1272653) 
droit - destra - derecha

LC12 LED p. 112



GLOWING

161280  

gauche - sinistra - izquierda



ORIGINAL

161000  

gauche - sinistra - izquierda



AMP 1.5-7P-M
arrière
connettore posteriore
conector trasero



161290  

droit - destra - derecha



161010  

droit - destra - derecha



D11868 **AMP 1.5-7P-F**

EPP96 LED p. 151



R14364 2000 mm

SS-2P-F

SMD04 p. 160



104140 1500 mm 

CLICK-IN



104100 1500 mm 

CLICK-IN

DE BUF

FA3 LED p. 174

LED

 12/24V



D14425

gauche - sinistra - izquierda





D14426

droit - destra - derecha



SL 1000 p. 186

LED

 12/24V

 R23



D14857



Feu homologué recul - Luce di retromarcia omologati
- Piloto marcha atrás homologado



D14170



SL 1500 p. 188

LED

 12/24V

NEW



D14851





D14170



ATLAS p. 220

LED

 12/24V



212420



D14513

LC12 LED p. 112

LED

 24V



161000

gauche - sinistra - izquierda



AMP 1.5-7P-M

arrière
connettore posteriore
conector trasero



161010

droit - destra - derecha



D11868

AMP 1.5-7P-F

LC8T p. 134



156250

gauche - sinistra - izquierda



AMP 1.5-7P-M

arrière
connettore posteriore
conector trasero



156260

droit - destra - derecha



D11868

AMP 1.5-7P-F



056720

gauche - sinistra - izquierda



056730

droit - destra - derecha



SMD04 p. 160

LED

 24V



104140

1500 mm 

CLICK-IN



104260

1500 mm 

CLICK-IN

FELDBINDER

SMD98

 p.161

LED

 24V



D10500 500 mm 

D11399 1500 mm 

CLICK-IN



D10497 500 mm 

CLICK-IN

FA3 LED

 p.174

LED

 12/24V



D14425

gauche - sinistra - izquierda **SS-2P-F**



D14426

droit - destra - derecha **SS-2P-F**

DXLC8

 p.175



D12712

gauche - sinistra - izquierda **POS-2P-F**



D12711

droit - destra - derecha **POS-2P-F**

ASR

 p.241

 12/24V

Standard



630120

87 dB



DUCATO

LC5

 p.138

07/2012 ->



Fixation 4 vis M6 (190x60mm)
Fijación 4 tornillos M6 (190x60mm)
4 vite di fissaggio M6 (190x60mm)



153270
(OE 1372699080)

gauche - sinistra - izquierda



AMP 1.5-7P-M

arrière
connettore posteriore
conector trasero



153280
(OE 1372698080)

droit - destra - derecha



D11868 AMP 1.5-7P-F



052500

gauche - sinistra - izquierda



052500

droit - destra - derecha



FPL93

 p.168



193360
(OE 1356794080 / 71749250)



SS-2P-M



193170
(OE 1305797)



SS-2P-M



001916



D13880

SS-2P-F

NEW



D16109
(OE 1940131)



gauche - sinistra - izquierda

NEW



D16108
(OE 1940132)



droit - destra - derecha



LC12 LED p. 112

LED

 24V



161000

gauche - sinistra - izquierda



AMP 1.5-7P-M
arrière
connettore posteriore
conector trasero



161010

droit - destra - derecha



LC8T p. 133



156040

gauche - sinistra - izquierda



AMP 1.5-7P-M
arrière
connettore posteriore
conector trasero



156050

droit - destra - derecha



D11868 **AMP 1.5-7P-F**



056700

gauche - sinistra - izquierda



056710

droit - destra - derecha



001830



BL15 p. 120

LED

 24V



165040

gauche - sinistra - izquierda



DT04-4P-M



DTM06-4S-4P-F



165050

droit - destra - derecha



D14436 **DT06-4S-4P-F**



D14437 **DTM06-4S-4P-F**



D14435 **DTM04-4P-M**

EPP96 LED p. 151

LED

 24V



D13609

400 mm

CLICK-IN

FRUEHAUF

EPP96

 p. 152



196020 R10W



D11888 1000 mm
CLICK-IN

DXLC8

 p. 175



D12712 350 mm
gauche - sinistra - izquierda **POS-2P-F**



D12711 350 mm
droit - destra - derecha **POS-2P-F**

FA3 LED

 p. 174

LED

 12/24V



D14427 1500 mm
gauche - sinistra - izquierda **CLICK-IN**



D14428 1500 mm
droit - destra - derecha **CLICK-IN**

SMD04

 p. 160

LED

 24V



104130 500 mm **K**

104140 1500 mm **K**

CLICK-IN



104090 500 mm **K**

104100 1500 mm **K**

CLICK-IN

5054

 p. 251



Max 6 kg

D14538

K Catadioptré
Catarifrangente
Catadióptrico

T Catadioptré triangulaire
Triangolo carifrangente
Catadióptrico triangular

K Connecteurs additionnels
Connettori addizionali
Conectores adicionales

LC12 LED

 p. 112

LED

 24V



161000



gauche - sinistra - izquierda



AMP 1.5-7P-M

arrière
connettore posteriore
conector trasero



161010



droit - destra - derecha



D11868

AMP 1.5-7P-F



D14781

SS-2P-F

gauche - sinistra - izquierda



D14782

SS-2P-F

droit - destra - derecha

LC5TDX

 p. 141



153660



gauche - sinistra - izquierda

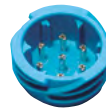

AMP 1.5-7P-M

arrière
connettore posteriore
conector trasero



153670



droit - destra - derecha



D11868

AMP 1.5-7P-F



053700



gauche - sinistra - izquierda



053710



droit - destra - derecha

EPP96 LED

 p. 151

LED

 24V



D13609

400 mm



CLICK-IN

LED

 24V

03/2016 ->





160150  
(OE 5802062689 / 5802240291)
gauche - sinistra - izquierda





HDSCS-8P-M
latéral
connettore laterale
conector lateral





160100  
(OE 5802000573 / 5802240295)
droit - destra - derecha





160080   
(OE 5802000568 / 5802240292)
gauche - sinistra - izquierda



160090   
(OE 5802000767 / 5802240296)
droit - destra - derecha

03/2016 ->





160110  
(OE 5802000570 / 5802240293)
gauche - sinistra - izquierda





HDSCS-8P-M
arrière
connettore posteriore
conector trasero





160130  
(OE 5802000770 / 5802240297)
droit - destra - derecha



160140   
(OE 5802055273 / 5802240294)
gauche - sinistra - izquierda



160120   
(OE 5802000772 / 5802240298)
droit - destra - derecha



D13878 **HDSCS-8P-F**





060000 
gauche - sinistra - izquierda



060010 
droit - destra - derecha

03/2016 ->



155450
(OE 5801637199)   
gauche - sinistra - izquierda



HDSCS-8P-M
latéral
connettore laterale
conector lateral



155460
(OE 5801637201)  
droit - destra - derecha





155470
(OE 5801637202)   
droit - destra - derecha

DESIGN EFFET FUMÉ - MÉTALLISÉ
DESIGN METALLIZZATO - FUMATO
DISEÑO EFECTO AHUMADO - METALIZADO

03/2016 ->



155480
(OE 5801637182)  
gauche - sinistra - izquierda





HDSCS-8P-M
arrière
connettore posteriore
conector trasero



155490
(OE 5801757328)  
droit - destra - derecha



155540
(OE 5802055272)   
gauche - sinistra - izquierda



155500
(OE 5801757326)   
droit - destra - derecha



D13878 **HDSCS-8P-F**



055040 
gauche - sinistra - izquierda



055050 
droit - destra - derecha



001830 
Alarme sonore de recul
Cicalino di retromarcia
Alarma sonora de marcha atrás

06/2011 -> EURO 6



153220
(OE 5801426889) 
gauche - sinistra - izquierda





AMP 1.5-7P-M
arrière
connettore posteriore
conector trasero





153210
(OE 5801426894) 
droit - destra - derecha



153200
(OE 5801426912)  
gauche - sinistra - izquierda



153230
(OE 5801426917)  
droit - destra - derecha



153240
(OE 5801426975) 
gauche - sinistra - izquierda



153250
(OE 5801426977) 
droit - destra - derecha

153260
(OE 5801426979)  
droit - destra - derecha



D11868 **AMP 1.5-7P-F**



052500
(OE 42566495) 
gauche - sinistra - izquierda



052500
(OE 42535711) 
droit - destra - derecha

FPL93

 p. 168



193020
(OE 500308514) 
JPT-2P-M



001726
(OE 1608352)



D13876 **SS-2P-F**

SMD98

 p. 166

-> 10/2014

 LED

 24V



198760
(OE 5801631615) 
SS-2P-M



D13880 **SS-2P-F**



STRALIS - TRAKKER - EURO CARGO

LC7

 p. 143

09/2011 -> EURO 6





169390
(OE 5801363428)  
gauche - sinistra - izquierda





DIN-8P-M
arrière
connettore posteriore
conector trasero





169410
(OE 5801363431)  
droit - destra - derecha



169400
(OE 5801363430)   
gauche - sinistra - izquierda



169420
(OE 5801363432)   
droit - destra - derecha



067500
(OE 93161844) 
gauche - sinistra - izquierda



067500
(OE 93161844) 
droit - destra - derecha



D12953 

STRALIS - TRAKKER - ASTRA HD7/HD8

C105

 p. 154

09/2012 ->



110550
(OE 5801572024)
gauche - sinistra - izquierda



110560
(OE 5801572018)
droit - destra - derecha



001619

FPL93

 p. 168



193170
(OE 41200664) 
superseal **SS-2P-M**



001916



D13880 **SS-2P-F**

2002 ->



168610
(OE 99463244)

gauche - sinistra - izquierda



IVECO
arrière
connettore posteriore
conector trasero



168600
(OE 99463242)

droit - destra - derecha



168480
(OE R504083205)

droit - destra - derecha



067500
(OE 93161844)

gauche - sinistra - izquierda



067500
(OE 93161844)

droit - destra - derecha



D12953



2002 -> 05/2007



119920
(OE 41221041)

gauche - sinistra - izquierda



119930
(OE 41221040)

droit - destra - derecha

05/2007 -> 09/2012



110520
(OE 42555042)

gauche - sinistra - izquierda



110530
(OE 42555041)

droit - destra - derecha



001619



Catadioptr
Catarifrangente
Catadióptrico



Feu de position latéral
Luce di posizione laterale
Piloto de posición lateral



Eclaireur de plaque
Luce targa
Iluminación de placa



Alarme sonore de recul
Cicalino di ritromarcia
Alarma sonora de marcha atrás



EUROCARGO

LC7

 p. 143

1996 ->





168590
(OE 99463243)  
gauche - sinistra - izquierda





IVECO
arrière
connettore posteriore
conector trasero



168600
(OE 99463242)  
droit - destra - derecha



168610
(OE 99463244)   
gauche - sinistra - izquierda



067500
(OE 93161844) 
gauche - sinistra - izquierda



067500
(OE 93161844) 
droit - destra - derecha

C105

 p. 154

06/2008 -> 09/2012



110520
(OE 42555042)
gauche - sinistra - izquierda



110530
(OE 42555041)
droit - destra - derecha

09/2012 ->



110550
(OE 5801572024)
gauche - sinistra - izquierda



110560
(OE 5801572018)
droit - destra - derecha





001619

LC7

 p. 143

1996 -> 2002



168610
(OE 99463244)   
gauche - sinistra - izquierda



IVECO
arrière
connettore posteriore
conector trasero



168600
(OE 99463242)  
droit - destra - derecha



067500
(OE 93161844) 
gauche - sinistra - izquierda



067500
(OE 93161844) 
droit - destra - derecha

FPL93

 p. 168



193020
(OE 500308514) 



001726
(OE 1608352)



D13876 

MASSIF 4 X 4

LC5

 p. 137

2002 ->



152180
(OE 791123) 
gauche - sinistra - izquierda

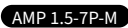

arrière
connettore posteriore
conector trasero



152180
(OE 791123) 
droit - destra - derecha



D11868 



052500
(OE A610067-002) 
gauche - sinistra - izquierda



052500
(OE A610067-002) 
droit - destra - derecha

DAILY LC15

 p. 137

07/2021 >

NEW



154200
(OE 5802830033 EZ)
gauche - sinistra - izquierda





AMP 1.5-7P-M
arrière
connettore posteriore
conector trasero

NEW



154210
(OE 5802830034 EZ)
droit - destra - derecha



NEW



154220
(OE 5802980630 EZ)
gauche - sinistra - izquierda



NEW



154220
(OE 5802980631 EZ)
droit - destra - derecha





D11868 **AMP 1.5-7P-F**



053730
(OE 5802984152 EZ)
gauche - sinistra - izquierda





053730
(OE 5802984152 EZ)
droit - destra - derecha



725

 p. 148

06/2006 -> 06/2021



D12334
(OE 69500032)
gauche - sinistra - izquierda





AMP 1.5-6P-M
arrière
connettore posteriore
conector trasero



D12335
(OE 69500026)
droit - destra - derecha





D11868 **AMP 1.5-7P-F**



D12336
(OE 42555132)
gauche - sinistra - izquierda





D12337
(OE 42555131)
droit - destra - derecha



06/2006 ->



D12338
(OE 69500591) **3.5T** **K**

D12340
(OE 69500047) **5T** **K**

gauche - sinistra - izquierda



D12339
(OE 69500590) **3.5T** **K**

D12341
(OE 69500044) **5T** **K**

droit - destra - derecha

725

i p. 148

1999 -> 06/2006



D11482
(OE 500356783) **K**

gauche - sinistra - izquierda



AMP 1.5-5P-M
arrière
connettore posteriore
conector trasero



D11481
(OE 500356782) **K**

droit - destra - derecha



D11868 **AMP 1.5-7P-F**

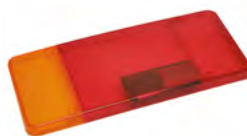

D11480 **K**

gauche - sinistra - izquierda



D11479 **K**

droit - destra - derecha

LC7

i p. 143

1996 -> 1999



168590
(OE 99463243) **K** **FPL**

gauche - sinistra - izquierda



IVECO
arrière
connettore posteriore
conector trasero



168600
(OE 99463242) **K** **FPL**

droit - destra - derecha



067500
(OE 93161844) **K**

gauche - sinistra - izquierda



067500
(OE 93161844) **K**

droit - destra - derecha

1996 ->



193020
(OE 500308514)

K

JPT-2P-M



001726
(OE 1608352)



D13876

JPT-2P-F



193290
(OE 504097923)

K

SS-2P-M



D13880

SS-2P-F

LAMBERET

LC12T LED

 p.112

LED

 24V



161000

gauche - sinistra - izquierda



AMP 1.5-7P-M
arrière
connettore posteriore
conector trasero



161010

droit - destra - derecha



D11868 **AMP 1.5-7P-F**



D11689 **AMP 1.5-7P**

LC12 LED

 p.112

LED

 24V



161260

gauche - sinistra - izquierda



AMP 1.5-7P-M
arrière
connettore posteriore
conector trasero



161270

droit - destra - derecha



D11868 **AMP 1.5-7P-F**



D11689 **AMP 1.5-7P**

LC8T

 p.133



156040

gauche - sinistra - izquierda



AMP 1.5-7P-M
arrière
connettore posteriore
conector trasero



156050

droit - destra - derecha



D11868 **AMP 1.5-7P-F**



056700

gauche - sinistra - izquierda



056710

droit - destra - derecha



D11689 **AMP 1.5-7P**



LC8

 p. 130



156310

gauche - sinistra - izquierda



AMP 1.5-7P-M

arrière
connettore posteriore
conector trasero



156300

droit - destra - derecha



D11868

AMP 1.5-7P-F

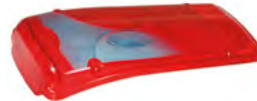

056500

gauche - sinistra - izquierda



056510

droit - destra - derecha



D11689

AMP 1.5-7P

LC5T

 p. 140



153000

gauche - sinistra - izquierda



AMP 1.5-7P-M

arrière
connettore posteriore
conector trasero



153010

droit - destra - derecha



D11868

AMP 1.5-7P-F



053700

gauche - sinistra - izquierda



053710

droit - destra - derecha



LPL18

 p. 150

LED

 12/24V



199040

SS-2P-M



D13880

SS-2P-F

LAMBERET

EPP96 LED

 p. 151

LED

 24V



D13874 2000 mm
POS-2P-F

EPP96

 p. 152



196020



D10227 700 mm
POS-2P-F

FE04

 p. 170

LED

 24V



104330 500 mm

SMD04

 p. 160

LED

 24V



104130 500 mm **K**
CLICK-IN



104090 500 mm **K**
104100 1500 mm **K**
CLICK-IN



104170 500 mm **K**
CLICK-IN



D14214
POS-2P-M

SMD98 p.166

LED

 24V



D10496 1500 mm 

CLICK-IN



001716

FA3 LED p.174

LED

 12/24V



D13875 1000 mm

SL 1000 p.186

LED

 12/24V

 R23



D14880

RCL 1200 p.215

LED

 9/30V

 1200 Lumen



300010



300000

chromé - cromato - cromado

MDJ p.265



175020

LED

24V



Exemple de montage - Esempio di montaggio - Ejemplo de montaje



164050
(OE 661058)



164010

Pour raccordement sur feu BL15
Per collegamento su fanale BL15
Para conectar sobre piloto BL15



165020

gauche - sinistra - izquierda



165030

droit - destra - derecha



D11689 **AMP 1.5-7P**

LC8T p.134



156250  
gauche - sinistra - izquierda



AMP 1.5-7P-M
arrière
connettore posteriore
conector trasero



156260  
droit - destra - derecha



156380   
gauche - sinistra - izquierda



156390   
droit - destra - derecha



D11868 **AMP 1.5-7P-F**



056720 
gauche - sinistra - izquierda



056730 
droit - destra - derecha

LC5T p.140



153000 
gauche - sinistra - izquierda



AMP 1.5-7P-M
arrière
connettore posteriore
conector trasero



153010 
droit - destra - derecha



153130  
droit - destra - derecha



D11868 **AMP 1.5-7P-F**



053700 
gauche - sinistra - izquierda



053710 
droit - destra - derecha

LECINENA

LC12T LED

 p.112

LED

 24V



161000

gauche - sinistra - izquierda



AMP 1.5-7P-M

arrière
connettore posteriore
conector trasero



161010

droit - destra - derecha



D11868

AMP 1.5-7P-F



D11689

AMP 1.5-7P

SMD04

 p.160

LED

 24V



104140

1500 mm 

CLICK-IN



104100

1500 mm 

CLICK-IN



104250

500 mm 

CLICK-IN

FPL93

 p.162

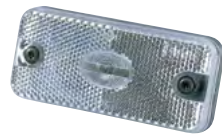

193200



JPT-2P-M



001726



D13876

JPT-2P-F

SMD98

 p.166

LED

 24V



D10494

500 mm 



001786

500 mm 



LC12 LED p. 112

LED

 24V



161000

gauche - sinistra - izquierda



AMP 1.5-7P-M
arrière
connettore posteriore
conector trasero



161010

droit - destra - derecha



D11868

AMP 1.5-7P-F



D14781

SS-2P-F

gauche - sinistra - izquierda



D14782

SS-2P-F

droit - destra - derecha

LCR19 p. 114

LED

 24V

NEW



213070

AMP MCP-4P-M

Position Glowing - Stop - Clignotant
Posizione Glowing - Stop - Indicatore
Posición Glowing - Stop - Intermitente

NEW



213150

AMP MCP-4P-M

Recul - Brouillard
Retromarcia - Retronebbia
Marcha atrás - Antiniebla



002100

POS
Position
Posizione
Posición



POS

POS



R23

SL 1000 p. 186

LED

 12/24V

 **R23**



D14857

DT-2P-M

Feu homologué recul - Luce di retromarcia omologati
- Piloto marcha atrás homologado





D14170

DT-2P-F

04/2017 ->
12V





155550  
(OE 65.25225-6004 / 7CE 945 095)
gauche - sinistra - izquierda



AMP 1.5-7P-M
arrière
connettore posteriore
conector trasero





155560  
(OE 65.25225-6005 / 7CE 945 096)
droit - destra - derecha

TGA - TGL - TGM - TGX - TGS

2005 ->





156200   
(OE 8125225-6544)
gauche - sinistra - izquierda



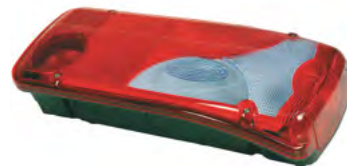

AMP 1.5-7P-M
latéral
connettore laterale
conector lateral



156210  
(OE 8125225-6545)
droit - destra - derecha



156220   
(OE 8125225-6547)
droit - destra - derecha



D11868 **AMP 1.5-7P-F**



056500 
(OE 8125229-6059 / 65.25229.0000 / 7CE 945 111)
gauche - sinistra - izquierda



056510 
(OE 8125229-6060 / 65.25229.001 / 7CE 945 112)
droit - destra - derecha



001830 90 Db
001872 55-90 Db

LED

 10/110V

03/2018 ->



212020 
(OE 81.25207-6074)
POS-2P-M



212030 
(OE 81.25207-6075)
POS-2P-M



D13879 **POS-2P-F**

SLA 2000

 p. 189

01/2022 ->

LED

 12/24V

NEW



D16110
(OE 81.25103-6076)

LEAR-2P-M

TGA

LC7

 p. 142

1999 -> 2005



169180
(OE 8125225-6526)

K FPL

gauche - sinistra - izquierda



AMP 1.5-7P-M

latéral
connettore laterale
conector lateral



169170
(OE 8125225-6523)

K FPL

droit - destra - derecha



169160
(OE 8125225-6524)

K FPL EPP

gauche - sinistra - izquierda



169190
(OE 8125225-6530)

K FPL 

droit - destra - derecha



D11868 **AMP 1.5-7P-F**



067500
(OE 8125229-6051)

K

gauche - sinistra - izquierda



067500
(OE 8125229-6051)

K

droit - destra - derecha

1990 -> 2004



168090
(OE 8125225-6033)



gauche - sinistra - izquierda



DIN 72480-8P-M

arrière
connettore posteriore
conector trasero



168090
(OE 8125225-6464)



droit - destra - derecha



168100
(OE 8125225-6034)



gauche - sinistra - izquierda



168490
(OE 8125225-6528)



droit - destra - derecha



067500
(OE 8125229-6051)



gauche - sinistra - izquierda



067500
(OE 8125229-6051)



droit - destra - derecha

ACTROS - UNIMOG

ATLAS

 p. 220



ACTROS 08/2020 ->

UNIMOG 03/2023 ->



LED

 24V



212710
(OE A 960 820 02 58 / A 960 820 03 58)  
MQS-2P-M





212420
(OE A 910 906 69 00 / A 405820 0158)  

ZETROS

LC8

09/2019 ->





155590
(OE A 959 544 01 03)   
gauche - sinistra - izquierda





AMP 1.5-7P-M
arrière
connettore posteriore
conector trasero



155600
(OE A 959 544 02 03)  
droit - destra - derecha



155610
(OE A 959 544 03 03)   
droit - destra - derecha



D11868 **AMP 1.5-7P-F**



056540
(OE A 000 826 20 56) 
gauche - sinistra - izquierda



056550
(OE A 000826 21 56) 
droit - destra - derecha



001830
Alarme sonore de recul
Cicalino di retromarcia
Alarma sonora de marcha atrás

LC11



 p. 117

03/2018 ->

LED

 12V





160400
(OE A 910 820 64 00)   

gauche - sinistra - izquierda



AMP 1.5-7P-M
arrière
connettore posteriore
conector trasero



160410
(OE A 910 820 65 00)  

droit - destra - derecha



D11868 **AMP 1.5-7P-F**



060000
(OE A 910 826 10 00) 

gauche - sinistra - izquierda



060010
(OE A 910 826 11 00) 



droit - destra - derecha

LC8

 p. 132

06/2006 ->





156340
(OE A 906 820 04 64)   

gauche - sinistra - izquierda



AMP 1.5-7P-M
arrière
connettore posteriore
conector trasero



156350
(OE A 906 820 17 64)  

droit - destra - derecha



D11868 **AMP 1.5-7P-F**



056540
(OE A 000 826 20 56) 

gauche - sinistra - izquierda



056550
(OE A 000 826 21 56) 

droit - destra - derecha

ATLAS



 p. 220

03/2018 ->

LED



 9/32V



212010
(OE A 910 906 29 00 / A 910 906 64 00)  

KOSTAL-2P-M



212420
(OE A 910 906 69 00)  

ECONIC

SMD98

 p. 166

04/2019->

LED

 24V



198760
(OE A 956 544 00 11)

K

SS-2P-M



D13880

SS-2P-F

FE08 H1

04/2019->

LED

 24V



116200
(OE A 956 820 00 59)

ATLAS

 p. 220

11/2023 ->

LED

 9/32V



212710
(OE A 960 820 02 58)



MQS-2P-M

SONDERFAHRZEUG

EPP96

 p. 152



06/2012 -> Lowliner



196170
(OE A 949 540 01 04) 500 mm

HDSCS-3P-M



152170
(OE 26555-9X126)  
gauche - sinistra - izquierda





AMP 1.5-7P-M
arrière
connettore posteriore
conector trasero



152180
(OE 26555-9X125) 
droit - destra - derecha



153120
(OE 26555-9X128)  
droit - destra - derecha



D11868 **AMP 1.5-7P-F**



052500
(OE 26554-9X126) 
gauche - sinistra - izquierda



052500
(OE 26554-9X126) 
droit - destra - derecha



119550
(OE 26164-9X402) **JPT-3P-M**



001616
(OE 26244-9X400)



D13877 **JPT-3P-F**

LC12 LED p. 112

LED

 24V



161280

gauche - sinistra - izquierda



AMP 1.5-7P-M

arrière
connettere posteriore
conector trasero



161290

droit - destra - derecha



D11868

AMP 1.5-7P-F



D14781

SS-2P-F

gauche - sinistra - izquierda



D14782

SS-2P-F

droit - destra - derecha

LCR19 p. 114

LED

 24V

NEW



213010

AMP MCP-4P-M

Position Glowing - Stop - Clignotant
Posizione Glowing - Stop - Indicatore
Posición Glowing - Stop - Intermitente

NEW



213070

AMP MCP-4P-M

Position Glowing - Stop - Clignotant
Posizione Glowing - Stop - Indicatore
Posición Glowing - Stop - Intermitente

NEW



213150

AMP MCP-4P-M

Recul - Brouillard
Retromarcia - Retronebbia
Marcha atrás - Antiniebla

SMC
Position lateral clignotant
Posizione laterale lampeggiante
Posición lateral e intermitente

POS
Position
Posizione
Posición

RI
Resistance integree (contrôle défaillance indicateur)
Resistenza integrata (controllo errore intermittente)
Resistencia integrada (control de fallo del intermitente)

RI



SMC

POS



POS

POS



R23

EPP96 LED p. 151

LED

 12/24V



R14364

SS-2P-M

SMD04 p. 160

LED

 12/24V



104690

K

SS-2P-M



104670

K

SS-2P-M



D13880

SS-2P-F

CARBONLUX p. 186

LED

 10/30V

 R23



D14811

DT-2P-M



Interrupteur - interruttore - interruptor



D14170

DT-2P-F

5054 p. 251



Max 6 kg

D14538

MOVANO - VIVARO

LC5

 p. 137

04/2010 ->



152180
(OE 4421265)

gauche - sinistra - izquierda





AMP 1.5-7P-M

arrière
connettore posteriore
conector trasero



152180
(OE 4421266)

droit - destra - derecha





D11868 **AMP 1.5-7P-F**



052500

gauche - sinistra - izquierda





052500

droit - destra - derecha



EPP98

 p. 152

04/2010 ->



196010
(OE 4421269)

JPT-2P-M



D13876

JPT-2P-F

07/2012 ->



Fixation 4 vis M6 (190x60mm)
Fijación 4 tornillos M6 (190x60mm)
4 vite di fissaggio M6 (190x60mm)



153270 
(OE 6350FS / 9815127080)

gauche - sinistra - izquierda



AMP 1.5-7P-M

arrière
connettore posteriore
conector trasero



153280 
(OE 6351FS / 9815126980)

droit - destra - derecha



D11868 



052500 

gauche - sinistra - izquierda



052500 

droit - destra - derecha

EURO 6 - T / K / C

LC9 LED

 p. 118



EURO 6

LED

 24V

12/2017->





158030
(OE 7425982261 / 7422800385 /
7484585208)   

gauche - sinistra - izquierda





AMP 1.5-7P-M
latéral
connettore laterale
conector lateral



158050
(OE 7425982262 / 7423080010 /
7484585206)  

droit - destra - derecha



158040
(OE 7425982262 / 7422800386 /
7484585204)   

droit - destra - derecha



D11868 **AMP 1.5-7P-F**



058000
(OE 7422800391) 

gauche - sinistra - izquierda



058000
(OE 7422800391) 

droit - destra - derecha

ATLAS

 p. 220

LED

 9/32V

09/2021->



212740
(OE 23811106)



AMP-4P-F



212750
(OE 23811107)



AMP-4P-F

TRI

 p. 184



D10596
(OE 7423374865)

RENAULT TRUCKS

EURO 6 - T / K / C --> 520 CH



LC9

 p. 135

EURO6

11/2013 ->



159010
(OE 7420802348)   
gauche - sinistra - izquierda



AMP 1.5-7P-M
latéral
connettore laterale
conector lateral



159020
(OE 7420802350)  
droit - destra - derecha



159030
(OE 7420802353)
droit - destra - derecha



D11868 **AMP 1.5-7P-F**



059000
(OE 7420802418) 
gauche - sinistra - izquierda



059000
(OE 7420802418) 
droit - destra - derecha



D12953 

LC10 LED

 p. 119



EURO6



 24V

09/2020->





159500
(OE 7423530440)   
gauche - sinistra - izquierda





AMP 1.5-7P-M
latéral
connettore laterale
conector lateral



159530
(OE 7423530442)  
droit - destra - derecha



159520
(OE 7423530438)  
gauche - sinistra - izquierda



159510
(OE 7423530441)   
droit - destra - derecha



D11868 **AMP 1.5-7P-F**



059500
(OE 7423292490) 
gauche - sinistra - izquierda



059500
(OE 7423292490) 
droit - destra - derecha

EURO 6 - T / K / C --> 520 CH

SMD00

 p. 167

EURO6

LED

 24V

12/2013->



198620
(OE 7482392733)

Cuve blanche - cabochon PMMA
Scatola bianca - lente PMMA
Caja blanca - tulipa PMMA





198740
(OE 7482586940)

Cuve ambre - cabochon PC haute température
Scatola arancione - lente PC temperatura elevata
Caja naranja - tulipa PC temperatura alta



FE18

EURO6

09/2021 ->

NEW



123000
(OE 7423398399)

gauche - sinistra - izquierda

NEW



123000
(OE 7423398399)

droit - destra - derecha

NEW



123020
(OE 7423398397)

gauche - sinistra - izquierda

NEW



123010
(OE 7423398400)

droit - destra - derecha

SL18

EURO6

09/2021 ->

NEW



113100
(OE 7423398635)

Feu d'embranchement
Luce d'identificazione apertura porte
Piloto identificación apertura puertas

FE09

EURO6

11/2013 -> 10/2021



115020
(OE 7482346591)
gauche - sinistra - izquierda



115020
(OE 7482346591)
droit - destra - derecha



115000
(OE 7482252506)
gauche - sinistra - izquierda



115010
(OE 7482367030)
droit - destra - derecha



115040
(OE 7482252291)



115030
(OE 7482255014)

SL08

EURO6

11/2013 -> 10/2021



113020
(OE 7482266219) 10W

Lampe de portière
Luce di portiera
Piloto de puerta



113030
(OE 7482285707) 5W

Feu d'embranchement
Luce d'identificazione apertura porte
Piloto identificación apertura puertas



MAGNUM

LC9

 p.135

01/2006 ->



159010
(OE 7420802348)   
gauche - sinistra - izquierda



AMP 1.5-7P-M
latéral
connettore laterale
conector lateral



159020
(OE 7420802350)  
droit - destra - derecha



159030
(OE 7420802353)   
droit - destra - derecha



D11868 **AMP 1.5-7P-F**



059000
(OE 7420802418) 
gauche - sinistra - izquierda



059000
(OE 7420802418) 
droit - destra - derecha







D12953 

LC7

 p.141

09/2004 -> 01/2006





169310
(OE 5001864535)    
gauche - sinistra - izquierda



AMP 1.5-7P-M
latéral
connettore laterale
conector lateral



169320
(OE 5001864536)   
droit - destra - derecha



Entraxe : 160 mm
Distanza tra le viti posteriori : 160 mm
Distancia entre tornillos : 160 mm



D11868 **AMP 1.5-7P-F**





067500
(OE 5001847588) 
gauche - sinistra - izquierda



067500
(OE 5001847588) 
droit - destra - derecha

12/1998 -> 09/2004



169020
(OE 5001847586)  
gauche - sinistra - izquierda





AMP 1.5-7P-M
latéral
connettore laterale
conector lateral



169030
(OE 5001847587) 
droit - destra - derecha



169000
(OE 5001847584)   
gauche - sinistra - izquierda

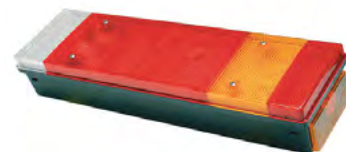

169010
(OE 5001847585)  
droit - destra - derecha



D11868 **AMP 1.5-7P-F**

1990 -> 1994



167100
(OE 5000296592) 
gauche - sinistra - izquierda





PE arrière
guarnizione pressacavo
posteriore
presa estopa trasero



167000
(OE 5000296592)
droit - destra - derecha

1994 -> 12/1998



168220
(OE 5001831194)   
gauche - sinistra - izquierda



168260
(OE 5001832999)  
droit - destra - derecha



067000
(OE 5000296594)



067000
(OE 5000296594)

067500
(OE 5001847588) 
gauche - sinistra - izquierda

067500
(OE 5001847588) 
droit - destra - derecha

MAGNUM

LC6

 p. 145

1991 -> 12/1998



166100 *
(OE 5000296591)



gauche - sinistra - izquierda



PE
arrière
guarnizione pressacavo
posteriore
presa estopa trasero



166000 *
(OE 5000296591)

droit - destra - derecha

12/1998 -> 09/2004



169060
(OE 5001847582)



gauche - sinistra - izquierda



AMP 1.5-7P-M
latéral
connettore laterale
conector lateral



169070
(5001847583)

droit - destra - derecha



D11868 AMP 1.5-7P-F



066000
(OE 5000296593)

gauche - sinistra - izquierda



066000
(OE 5000296593)

droit - destra - derecha

RENAULT TRUCKS

MAGNUM

FE04

 p. 160

LED

 24V

06/2008 ->



104570
(OE 7421430181/7482562006)

DT-2P-M



104450
(OE 7421137718)

DT-2P-M



D14170

DT-2P-F

FPL93

 p. 168

1994 ->



193020
(OE 5010306792 / 7484538758) 

JPT-2P-M



001726
(OE 5001847589)



D13876

JPT-2P-F

FE02

 p. 162

2003 ->



102200
(OE 5001862030) 

Clippé - fissaggio con clip - fijación con clip

JPT-2P-M



001726
(OE 5001847589)



D13876

JPT-2P-F

PREMIUM / KERAX / EURO 6 - C --> 320 CH



LC9

 p.135

EURO 6

01/2006 ->



159010
(OE 7420802348)   
gauche - sinistra - izquierda



AMP 1.5-7P-M
latéral
connettore laterale
conector lateral



159020
(OE 7420802350)  
droit - destra - derecha



159030
(OE 7420802353)   
droit - destra - derecha



D11868 **AMP 1.5-7P-F**



059000
(OE 7420802418) 
gauche - sinistra - izquierda



059000
(OE 7420802418) 
droit - destra - derecha



D12953 

PREMIUM / KERAX

LC7





 p.141

Premium
09/2004 -> 01/2006
Kerax
09/2004 -> 09/2006



Entraxe : 160 mm
Distanza tra le viti posteriori : 160 mm
Distancia entre tornillos : 160 mm





169310
(OE 5001864535)    
gauche - sinistra - izquierda



AMP 1.5-7P-M
latéral
connettore laterale
conector lateral



169320
(OE 5001864536)   
droit - destra - derecha



D11868 **AMP 1.5-7P-F**



067500
(OE 5001847588) 
gauche - sinistra - izquierda



067500
(OE 5001847588) 
droit - destra - derecha

Premium
1999 -> 09/2004



169020

(OE 5001847586)

gauche - sinistra - izquierda



AMP 1.5-7P-M

latéral
connettore laterale
conector lateral



169030

(OE 5001847587)

droit - destra - derecha



Premium
1999 -> 09/2004
Kerax
09/1998 -> 09/2004



169000

(OE 5001847584)

gauche - sinistra - izquierda



169010

(OE 5001847585)

droit - destra - derecha



D11868

AMP 1.5-7P-F



067000

(OE 5000296594)

067500
(OE 5001847588)

gauche - sinistra - izquierda



067000

(OE 5000296594)

067500
(OE 5001847588)

droit - destra - derecha



D12953



Premium
1995 -> 1999
Kerax
1995 -> 09/1998



168220

(OE 5001831194)

168260
(OE 5001832999)

gauche - sinistra - izquierda



PE
arrière
guarnizione pressacavo
posteriore
presa estopa trasero

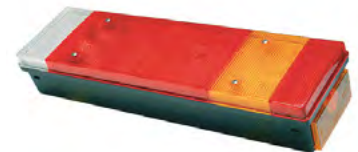

168260

(OE 5001832999)

168140
(OE 5001835853)

droit - destra - derecha



067000

(OE 5000296594)

gauche - sinistra - izquierda



067000

(OE 5000296594)

droit - destra - derecha

PREMIUM / KERAX

LC5

Premium
06/2001 -> 09/2004



152020 *
(OE 5001846847)

EPP



152510 **
(OE 5001857964)

EPP

gauche - sinistra - izquierda



AMP 1.5-7P-M

arrière
connettore posteriore
conector trasero



152500 **
(OE 5001858092)



152520 *
(OE 5001857965)

droit - destra - derecha

* pas de fonction recul
* no retromarcia
* no marcha atrás

** pas de fonction brouillard
** no retronebbia
** no antiniebla



D11868 AMP 1.5-7P-F



052000
(OE 5010392231)

gauche - sinistra - izquierda



052000
(OE 5010392231)

droit - destra - derecha

LC6

i p. 145

Premium
12/1998 -> 09/2004



169060
(OE 5001847582)

EPP

gauche - sinistra - izquierda



AMP 1.5-7P-M

latéral
connettore laterale
conector lateral



169070
(OE 5001847583)

droit - destra - derecha

Premium
1995 -> 12/1998



166100 *
(OE 5000296591)

EPP

gauche - sinistra - izquierda



PE
arrière
guarnizione pressacavo
posteriore
presa estopa trasero



166000 *
(OE 5000296591)

droit - destra - derecha

Kerax
1995 -> 09/1998



D11868 AMP 1.5-7P-F



066000
(OE 5000296593)

gauche - sinistra - izquierda



066000
(OE 5000296593)

droit - destra - derecha

FE95

 p.162

EURO 6

1995 ->



195010
(OE 5001834561)
gauche - sinistra - izquierda



195010
(OE 5001834561)
droit - destra - derecha

ICDL94

 p.157

EURO 6

1995 ->



119450
(OE 5001834565)

5W

JPT-3P-M



119470
(OE 5001847597)

21W

JPT-3P-M

Premium 12/1998 ->
Kerax 1999 ->



001616
(OE 5001834568)



D13877

JPT-3P-F

FE02

 p.162

EURO 6

2003 ->



102200
(OE 5001862030)

K

Clippé - fissaggio con clip - fijación con clip

JPT-2P-M



001726
(OE 5001847589)



D13876

JPT-2P-F

PREMIUM / KERAX / EURO 6 - C --> 320 CH

SMD98

 p.166



EURO6

LED

 24V

09/2007 ->



198650
(OE 7421106206) 
Feu d'identification Viscope
Luce di posizione Viscope 
Piloto de identificación Visera

D13876 

FPL93

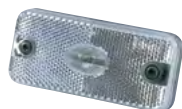

 p. 162

2003 ->



1995 ->



193200
(OE 5001862030) 
Vissé - Avviato - Atornillado 

193020
(OE 5010306792) 



001726
(OE 5001847589)





D13876 

MIDLINER

LC4

 p. 146



141500
(OE 5000808172)  
gauche - sinistra - izquierda



PE
arrière
guarnizione pressacavo pos-
teriore
prensa estopa trasero



141500
(OE 5000808172)  
droit - destra - derecha



040500
(OE 5000808166) 
gauche - sinistra - izquierda



040500
(OE 5000808166) 
droit - destra - derecha

RENAULT TRUCKS

EURO 6 - D --> 18 T

LC10 LED  p. 119



EURO 6

LED

 24V

09/2020->



159500
(OE 7423530440)   
gauche - sinistra - izquierda





AMP 1.5-7P-M
latéral
connettore laterale
conector lateral





159530
(OE 7423530442)  
droit - destra - derecha



159520
(OE 7423530438)  
gauche - sinistra - izquierda



159510
(OE 7423530441)   
droit - destra - derecha



D11868 **AMP 1.5-7P-F**



059500
(OE 7423292490) 
gauche - sinistra - izquierda



059500
(OE 7423292490) 
droit - destra - derecha



LC5

 p. 137

EURO 6

09/2021->



152170
(OE 5010595381)  
gauche - sinistra - izquierda



AMP 1.5-7P-M
arrière
connettore posteriore
conector trasero



152180
(OE 5010595382) 
droit - destra - derecha



D11868 **AMP 1.5-7P-F**



052500
(OE 5001847153) 
gauche - sinistra - izquierda



052500
(OE 5001847153) 
droit - destra - derecha



MIDLUM / EURO 6 - D --> 18 T

LC7

 p. 141

1999 -> 04/2006



169000
(OE 5001847584)   
gauche - sinistra - izquierda



AMP 1.5-7P-M
latéral
connettore laterale
conector lateral



169010
(OE 5001847585)  
droit - destra - derecha



D11868 AMP 1.5-7P-F



067500
(OE 5001847588) 
gauche - sinistra - izquierda



067500
(OE 5001847588) 
droit - destra - derecha

LC5

 p. 137

EURO 6

09/2005 ->



152880
(OE 7420862032) 
gauche - sinistra - izquierda



AMP 1.5-7P-M
arrière
connettore posteriore
conector trasero



152880
(OE 7420862035) 
droit - destra - derecha

1999 -> 09/2005



* pas de fonction recul
* no retromarcia
* no marcha atrás

** pas de fonction brouillard
** no retronebbia
** no antiniebla



152000 *
(OE 5001846843) 



152040 **
(OE 5001846845) 

gauche - sinistra - izquierda



152010 **
(OE 5001846844) 



152050 *
(OE 5001846846) 

droit - destra - derecha



D11868 AMP 1.5-7P-F



052500
(OE 5001847153) 
gauche - sinistra - izquierda



052500
(OE 5001847153) 
droit - destra - derecha

RENAULT TRUCKS

MIDLUM / EURO 6 - D --> 18 T

LC5

 p. 137

EURO6

09/2005 ->



152190
(OE 7420862038)



gauche - sinistra - izquierda



AMP 1.5-7P-M

arrière
connettore posteriore
conector trasero



152200
(OE 7420862041)

droit - destra - derecha

1999 -> 09/2005



* pas de fonction recul
* no retromarcia
* no marcha atrás

** pas de fonction brouillard
** no retronebbia
** no antiniebla



152020 *
(OE 5001846847)





152060 **
(OE 5001846849)



gauche - sinistra - izquierda



152030 **
(OE 5001846848)



152070 *
(OE 5001846850)

droit - destra - derecha



D11868 AMP 1.5-7P-F



052000
(OE 5010392231)

gauche - sinistra - izquierda



052000
(OE 5010392231)

droit - destra - derecha

EPP96

 p. 152

1999 -> 2003



196020
(OE 7700353021)

EPP98

 p. 152

EURO6

2003 ->



196010
(OE 5010293829)



D13876 JPT-2P-F

JPT-2P-M

MIDLUM / EURO 6 - D --> 18 T

FM91

08/2008 ->



191170
(OE 7421268609)

ICDL94

 p. 157

EURO6

-> 1999



119450
(OE 5001834565)

5W

JPT-3P-M

1999 ->



119470
(OE 5001847597)

21W

JPT-3P-M



001616
(OE 5001834568)



D13877

JPT-3P-F

FE95

 p. 162

EURO6

1999 ->



195010
(OE 5001834561)

gauche - sinistra - izquierda



195010
(OE 5001834561)

droit - destra - derecha

FE02

 p. 162

EURO6

2003 ->



102200
(OE 5001862030)

Clippé - fissaggio con clip - fijación con clip

JPT-2P-M



001726
(OE 5001847589)



D13876

JPT-2P-F

RENAULT TRUCKS

MIDLUM / EURO 6 - D --> 18 T

FPL93

 p. 168

1999 ->



193020
(OE 5010306792)

 JPT-2P-M



193280
(OE 7420894265)

 JPT-2P-M



001726
(OE 5001847589)



D13876 JPT-2P-F

MAXITY / EURO 6 - D --> 7,5 T

LC5

 p. 137

EURO6

2009 ->



152170
(OE 7485118470)
gauche - sinistra - izquierda



AMP 1.5-7P-M
arrière
connettore posteriore
conector trasero



152180
(OE 5001870556)
droit - destra - derecha





D11868 AMP 1.5-7P-F



052500
(OE 5001847153)
gauche - sinistra - izquierda





052500
(OE 5001847153)
droit - destra - derecha



MASCOTT

LC5

EURO 6

04/2006 ->



152880
(OE 7420862032) K
gauche - sinistra - izquierda



AMP 1.5-7P-M
arrière
connettore posteriore
conector trasero



152880
(OE 7420862035) K
droit - destra - derecha

07/2001 -> 04/2006

* pas de fonction recul
* no retromarcia
* no marcha atrás

** pas de fonction brouillard
** no retronebbia
** no antiniebla



152000 *
(OE 5001846843) K
gauche - sinistra - izquierda



152600 **
(OE 5001858093) K
droit - destra - derecha



D11868 **AMP 1.5-7P-F**



052500
(OE 5001847153) K
gauche - sinistra - izquierda



052500
(OE 5001847153) K
droit - destra - derecha

LC5

i p. 137

04/2006 ->



152170 K EPP
gauche - sinistra - izquierda



AMP 1.5-7P-M
arrière
connettore posteriore
conector trasero



152180 K
droit - destra - derecha



D11868 **AMP 1.5-7P-F**



052500
(OE 5001847153) K
gauche - sinistra - izquierda



052500
(OE 5001847153) K
droit - destra - derecha

LC5

07/2001 -> 04/2006

* pas de fonction recul
* no retromarcia
* no marcha atrás

** pas de fonction brouillard
** no retronebbia
** no antiniebla



152020 *
(OE 5001846847)

EPP



152510 **
(OE 5001857964)

EPP

gauche - sinistra - izquierda



AMP 1.5-7P-M

arrière
connettore posteriore
conector trasero



152500 **
(OE 5001858092)



152520 *
(OE 5001857965)

droit - destra - derecha



D11868 AMP 1.5-7P-F



052000
(OE 5010392231)

gauche - sinistra - izquierda



052000
(OE 5010392231)

droit - destra - derecha

LC4

p. 146

1998 -> 07/2001



141500
(OE 5000808172)

K EPP

gauche - sinistra - izquierda



PE
arrière
guarnizione pressacavo pos-
teriore
presa estopa trasero



141500
(OE 5000808172)

K EPP

droit - destra - derecha



040500
(OE 5000808166)

K

gauche - sinistra - izquierda



040500
(OE 5000808166)

K

droit - destra - derecha

EPP98

p. 152

1998 ->



196010
(OE 5010293829)

JPT-2P-M



D13876 JPT-2P-F

K

Catadioptr.
Catarifrangente
Catadióptrico

EPP

Eclaireur de plaque
Luce targa
Iluminación de placa

MASCOTT

ICDL94

 p. 157

1998 ->



119450
(OE 5001834565) 5W
JPT-3P-M



001616
(OE 5001834568)



D13877 **JPT-3P-F**

SMD98

 p.166

LED

 4xLEDS - 12V

1998 ->



198510
(OE 7700377208) **K**
JPT-2P-M



D13876 **JPT-2P-F**

CA

 p. 184

1998 -> 04/2006



D14590
(OE 7700377130)

04/2006 ->



D14593
(OE 8200602314)

TRAFIC

LC5

 p. 137

10/2014 ->



152180
(OE 265551402R) **K**

152180
(OE 265550674R) **K** 
gauche - sinistra - izquierda



AMP 1.5-7P-M

arrière
connettore posteriore
conector trasero



152180
(OE 265504514R) **K**

152180
(OE 265500292R) **K** 
droit - destra - derecha



D11868 **AMP 1.5-7P-F**



052500
(OE 5001847153) **K**
gauche - sinistra - izquierda



052500
(OE 5001847153) **K**
droit - destra - derecha

RENAULT TRUCKS

MASTER

LC5

 p. 137

04/2010 ->



152180
(OE 265551402R)



152180
(OE 265550674R)



gauche - sinistra - izquierda



AMP 1.5-7P-M

arrière
connettore posteriore
conector trasero



152180
(OE 265504514R)



152180
(OE 265500292R)



droit - destra - derecha



D11868

AMP 1.5-7P-F



052500
(OE 5001847153)



gauche - sinistra - izquierda



052500
(OE 5001847153)



droit - destra - derecha

EPP96

 p. 152

-> 04/2010



196020
(OE 7700353021)

EPP98

 p. 152

-> 04/2010



196010
(OE 265100848R)



D13876

JPT-2P-F

JPT-2P-M

SMD98

 p.166

LED

 4xLEDS - 12V

-> 04/2010



198580



JPT-2P-M



D13876

JPT-2P-F



GAMME B

LC4



p. 146



141000
(OE 5000808171)

gauche - sinistra - izquierda

EPP



PE
arrière
guarnizione pressacavo pos-
teriore
presa estopa trasero



141000
(OE 5000808171)

droit - destra - derecha

EPP



040000
(OE 5000807304)

gauche - sinistra - izquierda



040000
(OE 5000807304)

droit - destra - derecha

FPL93



p. 200



193020
(OE 5010306792 / 7484538758)

JPT-2P-M



001726
(OE 5001847589)



D13876 JPT-2P-F

LC4

 p. 146

-> 1986



141500

(OE 5000808172)

gauche - sinistra - izquierda



PE
arrière
guarnizione pressacavo pos-
teriore
prensa estopa trasero



141500

(OE 5000808172)

droit - destra - derecha



040500

(OE 5000808166)

gauche - sinistra - izquierda



040500

(OE 5000808166)

droit - destra - derecha



FE81

 p. 158



181050

(OE 5000461059)



181000

(OE 5000461058)

FE88

 p. 178



188310

(OE 5000623050)



088010

(OE 5000296718)



GAMME G



LC4

 p. 146

-> 1986



141000
(OE 5000808171) 

141500
(OE 5000808172)  
gauche - sinistra - izquierda



PE
arrière
guarnizione pressacavo pos-
teriore
presa estopa trasero



141000
(OE 5000808171) 

141500
(OE 5000808172)  
droit - destra - derecha



040000
(OE 5000807304)

040500
(OE 5000808166) 
gauche - sinistra - izquierda



040000
(OE 5000807304)

040500
(OE 5000808166) 
droit - destra - derecha

LC6

 p. 145

1986 ->



166000
(OE 5000296591) 

gauche - sinistra - izquierda



PE
arrière
guarnizione pressacavo pos-
teriore
presa estopa trasero



166000
(OE 5000296591)

droit - destra - derecha



066000
(OE 5000296593)
gauche - sinistra - izquierda



066000
(OE 5000296593)
droit - destra - derecha

RENAULT TRUCKS

GAMME J

FE81

 p. 158



181050
(OE 5000461059)



181000
(OE 5000461058)

FE88

 p. 178



188310
(OE 5000623050)



088010
(OE 5000296718)

FPL93

 p. 168



193020
(OE 5010306792 / 7484538758) 

 JPT-2P-M



001726
(OE 5001847589)



D13876  JPT-2P-F

GAMME R

LC7

 p. 142

1994 ->



167100
(OE 5000296592)

gauche - sinistra - izquierda





PE
arrière
guarnizione pressacavo
posteriore
presa estopa trasero



167000
(OE 5000296592)

droit - destra - derecha



168220
(OE 5001831194)

gauche - sinistra - izquierda



168260
(OE 5001832999)

droit - destra - derecha



067000
(OE 5000296594)

067500
(OE 5001847588)

gauche - sinistra - izquierda





067000
(OE 5000296594)

067500
(OE 5001847588)

droit - destra - derecha



LC4

 p. 146

-> 1994



141000
(OE 5000808171)

gauche - sinistra - izquierda





PE
arrière
guarnizione pressacavo pos-
teriore
presa estopa trasero



141000
(OE 5000808171)

droit - destra - derecha





040000
(OE 5000807304)

gauche - sinistra - izquierda



040000
(OE 5000807304)

droit - destra - derecha



RENAULT TRUCKS

GAMME R

FPL93

 p. 168



193020
(OE 5010306792 / 7484538758) 



001726
(OE 5001847589)



D13876 

GAMME S

LC4

 p. 146



141000
(OE 5000808171) 
gauche - sinistra - izquierda



PE
arrière
guarnizione pressacavo pos-
teriore
prensa estopa trasero



141000
(OE 5000808171) 
droit - destra - derecha



040000
(OE 5000807304)
gauche - sinistra - izquierda



040000
(OE 5000807304)
droit - destra - derecha

FE87

 p. 178



188310
(OE 5000623050)



088010
(OE 5000296718)



SERIE P&R

LC8

 p. 131

08/2013 ->



155080
(OE 2160128)   
gauche - sinistra - izquierda



AMP 1.5-7P-M
arrière
connettore posteriore
conector trasero





155520
(OE 2340796)  
droit - destra - derecha



155090
(OE 2160127)   
droit - destra - derecha

01/2007 ->





156770   
(OE 1756754/2021579/2129985)
gauche - sinistra - izquierda





AMP 1.5-7P-M
latéral
connettore laterale
conector lateral





156780  
(OE 1756751/2021575/2129987)
droit - destra - derecha



155020  
(OE 2021578/2129986)
droit - destra - derecha



156790   
(OE 1791369/2021576/2129988)
droit - destra - derecha



D11868 **AMP 1.5-7P-F**



056540 
(OE 1784669/2129992)
gauche - sinistra - izquierda





056550 
(OE 1784670/2129991)
droit - destra - derecha





001830 

1990 -> 1998

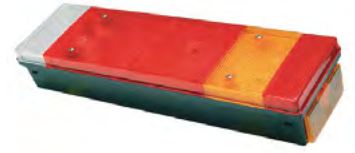

168350
(OE 1365963)   
gauche - sinistra - izquierda



168360
(OE 1365964)  
droit - destra - derecha



067500
(OE 1350343) 
gauche - sinistra - izquierda



067500
(OE 1350343) 
droit - destra - derecha

 LED

 12/24V

 2000 Lumen



D14852
(OE 2862201)



D14170 



D10596
(OE 2020496)

LC12 LED p. 112

LED

 24V

GLOWING

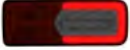

161280
(OE 1370066)
gauche - sinistra - izquierda



AMP 1.5-7P-M
arrière
connettore posteriore
conector trasero



161290
(OE 1370067)
droit - destra - derecha



D11868 **AMP 1.5-7P-F**

LC12 LED p. 112

LED

 24V

ORIGINAL



161000
(OE 1302341 / 1364736)
gauche - sinistra - izquierda



AMP 1.5-7P-M
arrière
connettore posteriore
conector trasero



161010
(OE 1302342 / 1364737)
droit - destra - derecha



D11868 **AMP 1.5-7P-F**

LCR19 p. 114

LED

 24V

SMC

Position lateral clignotant
Posizione laterale lampeggiante
Posición lateral e intermitente

POS

Position
Posizione
Posición

RI

Resistance integree (contrôle défaillance indicateur)
Resistenza integrata (controllo errore intermittente)
Resistencia integrada (control de fallo del intermitente)



213010
(OE 1415545)

AMP MCP-4P-M

Position Glowing - Stop - Clignotant
Posizione Glowing - Stop - Indicatore
Posición Glowing - Stop - Intermitente



213090
(OE 1415546)

AMP MCP-4P-M

Position Glowing - Stop - Clignotant
Posizione Glowing - Stop - Indicatore
Posición Glowing - Stop - Intermitente

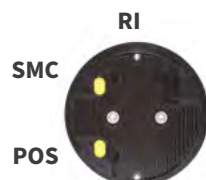

SMC

POS





D14846
(OE 1415543) **HDSCS-6P-F**
gauche - sinistra - izquierda



D14847
(OE 1415544) **HDSCS-6P-F**
droit - destra - derecha

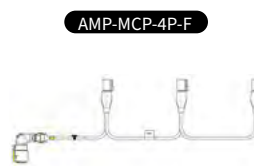

D14884
(OE 1437099) **HDSCS-6P-F**
gauche - sinistra - izquierda

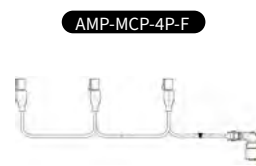

D14885
(OE 1437100) **HDSCS-6P-F**
droit - destra - derecha

LED

 10/30V



D14488
(OE 1348566)  



D14513

LC12 LED p. 112

LED

 24V



161000

gauche - sinistra - izquierda



AMP 1.5-7P-M

arrière
connettore posteriore
conector trasero



161010

droit - destra - derecha



D11868

AMP 1.5-7P-F



D14781

SS-2P-F

gauche - sinistra - izquierda



D14782

SS-2P-F

droit - destra - derecha

LC8T p. 133



156040

gauche - sinistra - izquierda



AMP 1.5-7P-M

arrière
connettore posteriore
conector trasero



156050

droit - destra - derecha



056700

gauche - sinistra - izquierda



056710

droit - destra - derecha



D12712

POS-2P-F

gauche - sinistra - izquierda



D12711

POS-2P-F

droit - destra - derecha



D11868

AMP 1.5-7P-F

EPP96 LED p. 151

LED

 24V



R14364

2000 mm

SS-2P-F

SOR IBERICA

EPP96

 p. 152



D11888

1000 mm

CLICK-IN

SMD04

 p. 165

LED

 24V



104100

1500 mm **K**

CLICK-IN



104650

1000 mm **K**

bride rallongée - supporto esteso - soporte extendido

CLICK-IN

SMCU

 p. 165

 12/24V

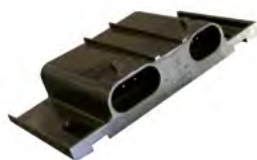

D14722

SS-2P-M **SS-3P-M**

FA3LED

 p. 174

LED

 12/24V



D14427

1500 mm

gauche - sinistra - izquierda

CLICK-IN



D14428

1500 mm

droit - destra - derecha

CLICK-IN



D14425

gauche - sinistra - izquierda

SS-2P-F



D14426

droit - destra - derecha

SS-2P-F

BL15 p. 120

LED

 24V



165040

gauche - sinistra - izquierda

165050

droit - destra - derecha



CTL15 p. 120

LED

 24V



164020

gauche - sinistra - izquierda

164030

droit - destra - derecha



CTL15-BL15 p. 121

LED

 24V

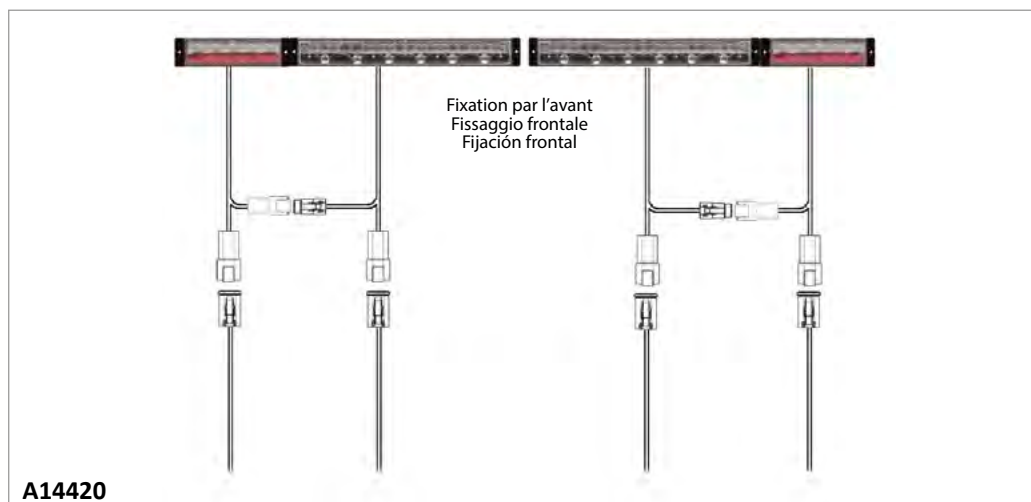

A14420

2 x CTL15 + 1 x BL15 gauche + 1 x BL15 droit + 4 câbles 8,5 m
 2 x CTL15 + 1 x BL15 sinistro + 1 x BL15 destro + 4 cavi 8,5 m
 2 x CTL15 + 1 x BL15 izquierdo + 1 x BL15 derecho + 4 cables 8,5 m

UD TRUCKS

QUON - QUESTER

LC9 LED - LC10 LED



REF. sur demande

Référence sur demande
P/N su richiesta
Ref. a petición



REF. sur demande

Référence sur demande
P/N su richiesta
Ref. a petición

LC5

p. 137

05/2015 ->



152180
(OE 261319Z01B)



153880 *
(OE 261319Z01D)



gauche - sinistra - izquierda



AMP 1.5-7P-M

arrière
connettore posteriore
conector trasero



152180
(OE 261319Z01C)



153890 *
(OE 261319Z01E)



droit - destra - derecha

* pas de fonction brouillard
* no retronebbia
* no antiniebla



D11868 **AMP 1.5-7P-F**



052500
(OE 265509Z00A)



gauche - sinistra - izquierda



052500
(OE 265509Z00A)



droit - destra - derecha

EPP98

p. 152

05/2015 ->



196010
(OE 265109Z00A)

JPT-2P-M



D13876 **JPT-2P-F**

ICDL15

p. 156

05/2015 ->



120000
(OE 84655961) PY21W - 24V

SS-2P-M



D13880 **SS-2P-F**



LC12 LED

i | p. 113

LED

24V

NEW



161700
161720

gauche - sinistra - izquierda



AMP 1.5-7P-M
arrière
connettore posteriore
conector trasero

NEW



161710
161730

droit - destra - derecha



D11868 **AMP 1.5-7P-F**

NEW



D14781 **SS-2P-F**

gauche - sinistra - izquierda

NEW



D14782 **SS-2P-F**

droit - destra - derecha

LPL18

i | p. 150

LED

12/24V

NEW



199040

SS-2P-M



D13880

SS-2P-F

LC8

 p. 127

06/2017 ->



155570

(OE 7CA 945 095)

gauche - sinistra - izquierda



AMP 1.5-7P-M

arrière
connettore posteriore
conector trasero



155580

(OE 7CA 945 096)

droit - destra - derecha



D11868

AMP 1.5-7P-F



055020

(OE 7CA 945 111)

gauche - sinistra - izquierda



055030

(OE 7CA 945 112)

droit - destra - derecha



LC5

 p. 137

06/2017 ->



152180

(OE 7CA 945 091)

gauche - sinistra - izquierda



AMP 1.5-7P-M

arrière
connettore posteriore
conector trasero



152180

(OE 7CA 945 092)

droit - destra - derecha



D11868

AMP 1.5-7P-F



052500

(OE 5001847153)

gauche - sinistra - izquierda



052500

(OE 5001847153)

droit - destra - derecha



LC8

 p. 132

06/2006 ->
05/2017



156340

(OE 2E0 945 095 A)

gauche - sinistra - izquierda



AMP 1.5-7P-M

arrière
connettore posteriore
conector trasero



156350

(OE 2E0 945 096 A)

droit - destra - derecha



D11868

AMP 1.5-7P-F



056540

(OE 2E0 945 111 A)

gauche - sinistra - izquierda



056550

(OE 2E0 945 112 A)

droit - destra - derecha



FH

LC9 LED



p. 118

12/2012 ->

LED

24V

**158030**

(OE 82849894 / 84195505 / 84441766 / 23354972)



gauche - sinistra - izquierda



AMP 1.5-7P-M

latéral
connettore laterale
conector lateral**158050**

(OE 82849923 / 84195521 / 84441768 / 23354974)



droit - destra - derecha

**158040**

(OE 82849925 / 84195519 / 84441767 / 23354973)



droit - destra - derecha

**D11868**

AMP 1.5-7P-F

**058000**

(OE 82849905)



gauche - sinistra - izquierda

**058000**

(OE 82849905)



droit - destra - derecha

SRD08



p. 155

09/2012 ->

LED

24V

**111000**

(OE 82151157)

gauche - sinistra - izquierda

**111010**

(OE 82151205)

droit - destra - derecha

**111020**

(OE 21346521)

gauche - sinistra - izquierda

**111030**

(OE 21346522)

droit - destra - derecha

FH 08/2008 -> 09/2012



107000
(OE 82114506 / 82355678 / 84139927)
gauche - sinistra - izquierda



107010
(OE 82114500 / 82355684 / 84139939)
droit - destra - derecha



107040
(OE 82114504 / 21448885)
gauche - sinistra - izquierda



107050
(OE 82114502 / 21478751)
droit - destra - derecha



FE08 H2

09/2012 ->



112010
(OE 82278930) 
gauche - sinistra - izquierda



112000
(OE 82278938) 
droit - destra - derecha

ID08

09/2012 ->



114000
(OE 21214534) 

114010
(OE 82150539) 

114020
(OE 21214524) 

FH

FE08 H1

09/2012 ->

LED

24V



116010
(OE 82349220)

116030
(OE 21368782)

gauche - sinistra - izquierda



116000
(OE 82349221)



116020
(OE 21368783)

droit - destra - derecha



116040
(OE 82348508)

116050
(OE 21368779)

116060
(OE 21368781)



FE07

08/2008 ->

LED

24V



207000
(OE 82116545)



207010
(OE 21087346)



207020
(OE 21087347)

SMD00

 p. 167

2001 ->

LED

 24V



198620
(OE 82392733)

Cuve blanche - cabochon PMMA
Scatola bianca - lente PMMA
Caja blanca - tulipa PMMA

K



198740
(OE 84044658)

Cuve ambre - cabochon PC haute température
Scatola arancione - lente PC temperatura elevata
Caja naranja - tulipa PC temperatura alta



001766
(OE 85105029)

adaptateur - adattatore - adaptador

FH

SL18

10/2021 ->

LED

 24V

NEW



113110
(OE 24080598)

Lampe de portière
Luce di portiera
Piloto de puerta

SL08

09/2012 ->
10/2021

 5W



113000
(OE 82202076)

Lampe de portière
Luce di portiera
Piloto de puerta

FH

ATLAS

 p. 220

04/2021 ->

LED

 9/32V



212730
(OE 23742314)



TYCO MCON-2P-M

FM

LC10 LED ⓘ p. 119

09/2013 ->

LED

⚡ 24V



159500 (OE 82483074 / 84441759 / 23522307 / 23690769)
gauche - sinistra - izquierda



AMP 1.5-7P-M
latéral
connettore laterale
conector lateral



159530 (OE 21735299 / 84441937 / 23522305 / 23690765)
droit - destra - derecha



159520 (OE 21735301 / 84441936 / 23522304 / 23690764)
gauche - sinistra - izquierda



159510 (OE 82483073 / 84441760 / 23522308)
droit - destra - derecha



D11868 AMP 1.5-7P-F



059500 (OE 84122332)
gauche - sinistra - izquierda



059500 (OE 84122332)
droit - destra - derecha

SRD07 ⓘ p. 155

09/2010 -> 10/2013

LED

⚡ 24V



107000 (OE 82114506 / 82355678)
gauche - sinistra - izquierda



107010 (OE 82114500 / 82355684)
droit - destra - derecha



107040 (OE 82114504 / 21448885)
gauche - sinistra - izquierda



107050 (OE 82114502 / 21478751)
droit - destra - derecha

11/2013 ->



107500 (OE 82467736)
gauche - sinistra - izquierda



107510 (OE 82467737)
droit - destra - derecha

08/2008 ->

LED

24V



207000
(OE 82116545)



207010
(OE 21087346)



207020
(OE 21087347)

LC9

i p. 135

01/2006 ->



159010
(OE 20769775) K FPL EPP
gauche - sinistra - izquierda



AMP 1.5-7P-M
latéral
connettore laterale
conector lateral



159020
(OE 20769776) K FPL
droit - destra - derecha



159030
(OE 20769777) K FPL Speaker
droit - destra - derecha



D11868 **AMP 1.5-7P-F**



059000
(OE 20802418) K
gauche - sinistra - izquierda



059000
(OE 20802418) K
droit - destra - derecha



D12953 Speaker

FL - FE

LC5

 p. 137

2006 ->



152190
(OE 20769783)

gauche - sinistra - izquierda





AMP 1.5-7P-M

arrière
connettore posteriore
conector trasero



152200
(OE 20769784)

droit - destra - derecha



152880
(OE 20769781)

gauche - sinistra - izquierda





152880
(OE 20769782)

droit - destra - derecha





D11868 **AMP 1.5-7P-F**



052000
(OE 20537280)

052500
(OE 20745060)

gauche - sinistra - izquierda





052000
(OE 20537280)

052500
(OE 20745060)

droit - destra - derecha



ICDL94

 p. 157



119550
(OE 21341202)

JPT-3P-M



001616
(OE 20745227)



D13877 **JPT-3P-F**

FE95

 p. 162



195010
(OE 20745225)

gauche - sinistra - izquierda



195010
(OE 20745225)

droit - destra - derecha

SH3

- * Lampe fournie
- * Con lampada
- * Lámpara incluida



D13019*
(OE 21396991)

DT-2P-M



D14170

DT-2P-F

FL

EPP98



p. 152



196010
(OE 20721495)

JPT-2P-M



D13876

JPT-2P-F

FE02



p. 162

2006 ->



102200
(OE 20717520)

K

Clippé - fissaggio con clip - fijación con clip

JPT-2P-M



001726
(OE 20745066)

D13876

JPT-2P-F



FPL93



p. 168



193020
(OE 20734485 / 84538758)

K

JPT-2P-M



001726
(OE 20745066)

D13876

JPT-2P-F



SMD98

 p.166

LED

 24V

-> 2003



198650
(OE 20480486)



JPT-2P-M



D13876

JPT-2P-F

SMD98

 p.171

LED

 24V

-> 2003



198640
(OE 70364301)



JPT-2P-M



D13876

JPT-2P-F

VOLVO CONSTRUCTION

SMD98

 p.166

LED

 24V



198520
(OE 11170068)

K

JPT-2P-M



D13876

JPT-2P-F

CHL1H4

 p.207

 24V
H4 - PY21 - W5W



D14320 12V

D14322 24V

gauche - sinistra - izquierda



DT-6P-M

arrière
connettore posteriore
conector trasero



D14321 12V

D14323 24V

droit - destra - derecha



D14352

DT-6P-F

TRI

 p.184



D10596
(OE 23374865)

K

Feux arrière

Fanali posteriori

Pilotos traseros

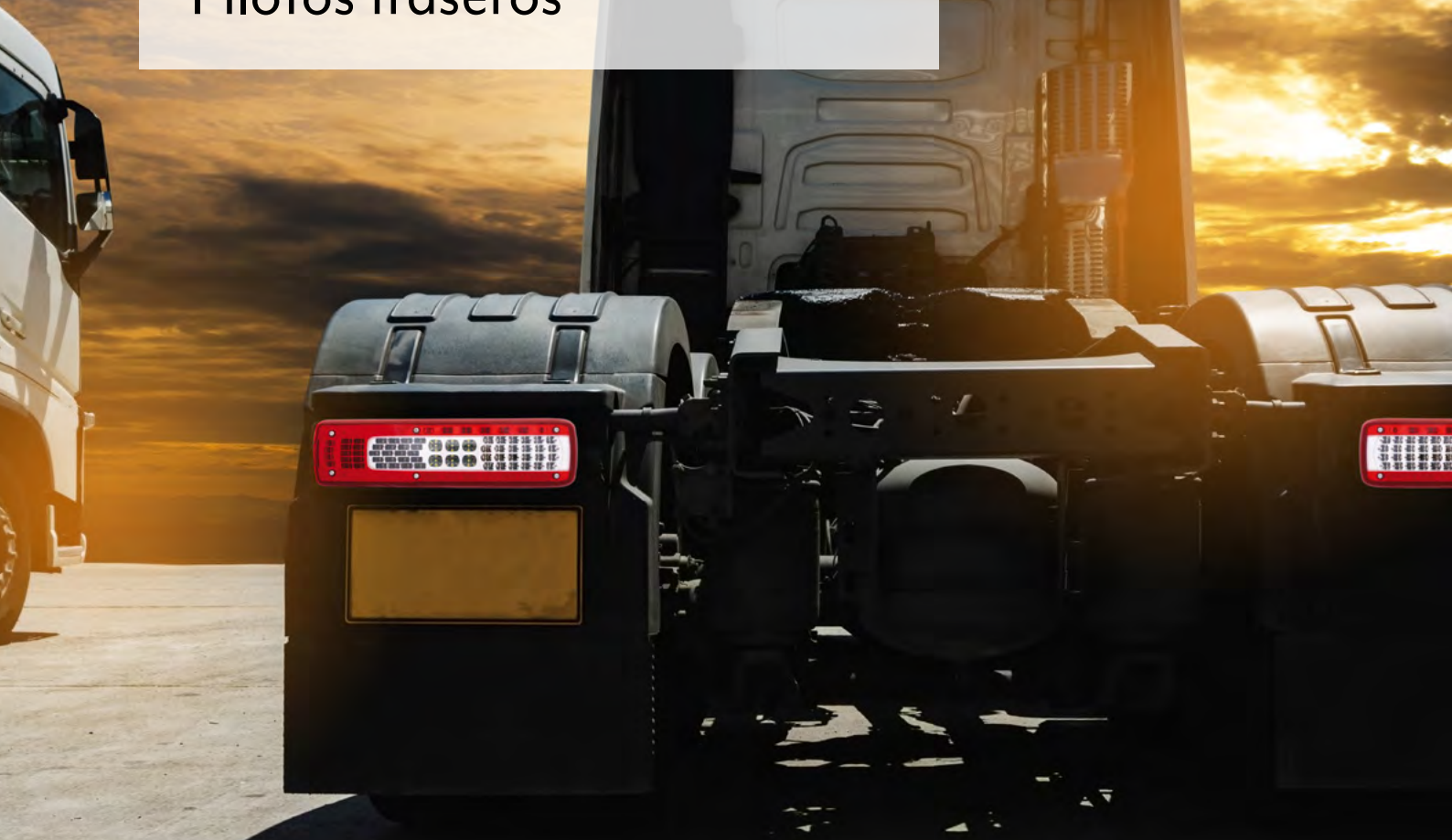

LED

p. 112-125



Halogène

p. 126-148



AMP 1.5-7P-M

Type connecteur - Nb pins - Mâle ou Femelle
 Tipo di connettore - Num pin - Maschio o Femmina
 Tipo de conector - Num pines - macho o hembra



Faisceau p. 267
 Cablaggio p. 267
 Cableado p. 267



Flashez le QR code pour plus d'infos
 Scansiona il codice QR per maggiori informazioni
 Escanee el código QR para obtener más info



Pièces détachées
 Ricambi
 Repuestos



Numéro d'homologation
 Numero di omologazione
 Número de aprobación



Sens de montage
 Direzione di montaggio
 Dirección de montaje

DETAIL CONNECTEUR 1-5	REPEREUR DES FONCTIONS CONNETTEUR PROTECTOR	FONCTION FUNCTION
1	1	USURE TARIF
2	2	POSITION TAR
3	3	SECTEUR
4	4	INDICATEUR DE DIRECTION INDICATOR
5	5	STOP
6	6	PROBALLARD
7	7	NOT USED

Pinning connecteurs sur notre site web
 Pinning dei connettori sul nostro sito web
 Pinning conectores en nuestro sitio web

Feux arrière - Fanali posteriori - Pilotos traseros

LC12 LED

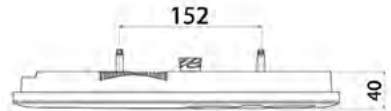
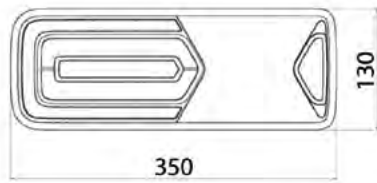

ORIGINAL



LED

ISO PULSE
13207-1

ADR



E2 16027
10R-0516057

Affectations constructeurs
Applicazione primo impianto
Afectación primer equipo

ALMAJDOUIE p. 8
ASCA p. 10
BENALU GROUP p. 14
DE BUF p. 25
FELDBINDER p. 27
FRUEHAUF p. 31
GROSSE EQUIPEMENT p. 33
LAMBERET p. 44
LEGINENA p. 49
MAGYAR p. 51
OMEPS p. 59
SCHMITZ p. 93
SOR IBERICA p. 95
VAK OY p. 99

GLOWING



LED

ISO PULSE
13207-1

ADR



E2 18042
10R-0516057



161000 24V

161200 12V

gauche - sinistra - izquierda



AMP 1.5-7P-M

arrière
connettore posteriore
conector trasero



161010 24V

161210 12V

droit - destra - derecha



161120 24V

161260 24V

161190 24V

gauche - sinistra - izquierda



161130 24V

161270 24V

161180 24V

droit - destra - derecha



161280 24V

161420 12V

gauche - sinistra - izquierda



AMP 1.5-7P-M

arrière
connettore posteriore
conector trasero



161290 24V

161430 12V

droit - destra - derecha



161500 24V

161560 24V

161460 24V

161580 12V

gauche - sinistra - izquierda



161510 24V

161570 24V

161470 24V

161590 12V

droit - destra - derecha



Clignotant dynamique
Dynamic indicator
Intermitente dinámico



Feux arrière - Fanali posteriori - Pilotos traseros

LC12 LED BLACK EDITION



NEW

LED

ISO PULSE
13207-1

ADR

H

E₂ 18042
10R-0516057



161700 24V

161720 24V

gauche - sinistra - izquierda



AMP 1.5-7P-M
arrière
connettore posteriore
conector trasero



161710 24V

161730 24V

droit - destra - derecha

4 connecteurs pour options
4 connettori per le opzioni
4 conectores para opciones

Position lateral clignotant
Posizione laterale lampeggiante
Posición lateral e intermitente

Recul
Retromarcia
Marcha Atrás

Position
Posizione
Posición

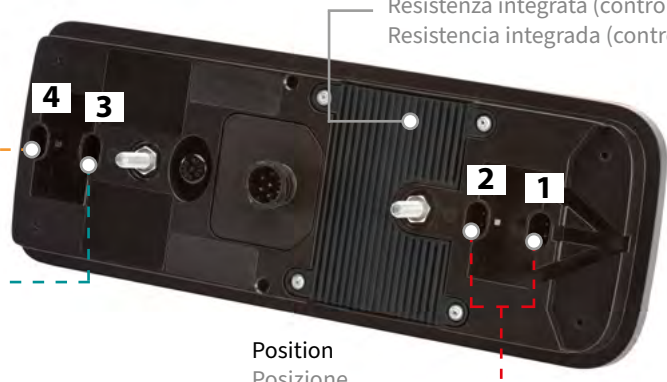

Resistance integree (contrôle défaillance indicateur)
Resistenza integrata (controllo errore intermittente)
Resistencia integrada (control de fallo del intermitente)

1+2+4 = 1 Amp maxi
3 = 1 Amp maxi



<p>104090 500 mm </p>	<p>104100 1500 mm </p>	<p>D14857 DT-2P-M</p>	<p>199040 SS-2P-M</p>	<p>D14781 SS-2P-F</p>	<p>D14782 SS-2P-F</p>
				gauche - sinistra - izquierda	droit - destra - derecha
<p>R14412 16 m</p>	<p>R14413 1500 mm</p>	<p>D14985 1500 mm</p>	<p>D14425 1500 mm</p>	<p>D14426 1500 mm</p>	
				gauche - sinistra - izquierda	droit - destra - derecha
<p>D11868 AMP 1.5-7P-F</p>	<p>R14426 1500 mm</p>	<p>R14418</p>			
		<p>Rallonge SUPERSEAL 2 voies Prolunga SUPERSEAL 2 vie Alargador SUPERSEAL 2 vías</p>			

Feux arrière - Fanali posteriori - Pilotos traseros

LCR19

GLOWING

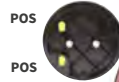
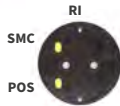
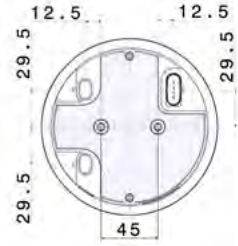
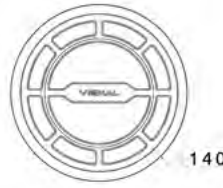

ISO PULSE
13207-1



24V



E₂ 19106

Affectations constructeurs
Applicazione primo impianto
Afectación primer equipo

BENALU GROUP p. 14
MAGYAR p. 51
OMEPS p. 59
SCHMITZ p. 93

213010

AMP MCP-4P-M

Position Glowing - Stop - Clignotant
Posizione Glowing - Stop - Indicatore
Posición Glowing - Stop - Intermitente

213070

AMP MCP-4P-M

Position Glowing - Stop - Clignotant
Posizione Glowing - Stop - Indicatore
Posición Glowing - Stop - Intermitente

213090

AMP MCP-4P-M

Position Glowing - Stop - Clignotant
Posizione Glowing - Stop - Indicatore
Posición Glowing - Stop - Intermitente

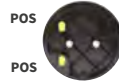
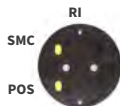

BLACK EDITION

NEW

213240

AMP MCP-4P-M

Position Glowing - Stop - Clignotant
Posizione Glowing - Stop - Indicatore
Posición Glowing - Stop - Intermitente

NEW

213300

AMP MCP-4P-M

Position Glowing - Stop - Clignotant
Posizione Glowing - Stop - Indicatore
Posición Glowing - Stop - Intermitente

R23



213150

AMP MCP-4P-M

Recul - Brouillard
Ritromarcia - Retronebbia
Marcha atrás - Antiniebla



213160

AMP MCP-4P-M

Recul - Brouillard
Ritromarcia - Retronebbia
Marcha atrás - Antiniebla



213200

AMP MCP-4P-M

Position Glowing - Recul - Brouillard
Posizione Glowing - Retromarcia - Retronebbia
Posición Glowing - Marcha atrás - Antiniebla

NEW

BLACK EDITION



213380

AMP MCP-4P-M

Recul - Brouillard
Retromarcia - Retronebbia
Marcha atrás - Antiniebla

NEW



213430

AMP MCP-4P-M



Position Glowing - Recul - Brouillard
Posizione Glowing - Retromarcia - Retronebbia
Posición Glowing - Marcha atrás - Antiniebla



Feux arrière - Fanali posteriori - Pilotos traseros





LCR19



			
D14984	AMP-MCP-4P-F	D14980	D14983
	AMP-MCP-4P-F		AMP-MCP-4P-F

Affectations constructeurs
Applicazione primo impianto
Afectación primer equipo

SCHMITZ p. 93

			
D14846	D14847	D14884	D14885
HDSCS-6P-F	HDSCS-6P-F	HDSCS-6P-F	HDSCS-6P-F
gauche - sinistra - izquierda	droit - destra - derecha	gauche - sinistra - izquierda	droit - destra - derecha

SMC
Position lateral clignotant
Posizione laterale lampeggiante
Posición lateral e intermitente

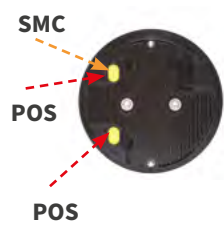



			
104090	199040	D14425	D14426
500 mm	1500 mm	1500 mm	1500 mm
CLICK-IN	SS-2P-M	SS-2P-F	SS-2P-F
		gauche - sinistra - izquierda	droit - destra - derecha

POS
Position
Posizione
Posición

* **SMC**
Position lateral clignotant
Posizione laterale lampeggiante
Posición lateral e intermitente

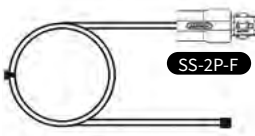

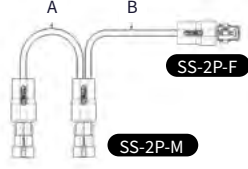
POS
Position
Posizione
Posición

			
R14412	D14985	R14426	R14418
16 m	1500 mm	1500 mm	A: 300 mm / B: 500 mm
SS-2P-F	SS-2P-F	SS-2P-M	SS-2P-F

RI
Resistance integree (contrôle défaillance indicateur)
Resistenza integrata (controllo errore intermittente)
Resistencia integrada (control de fallo del intermitente)

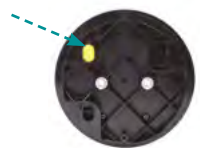
Rallonge SUPERSEAL 2 voies
Prolunga SUPERSEAL 2 vie
Alargador SUPERSEAL 2 vías

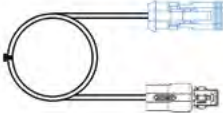

			
D14857	R14413		002100
DT-2P-M	1500 mm		Anneau chromé Anello cromato Anillo cromado

R23
Retromarcia
Marcha Atrás

Feux arrière - Fanali posteriori - Pilotos traseros

LC11

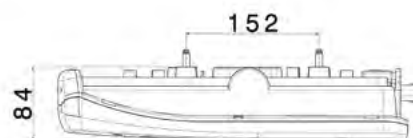
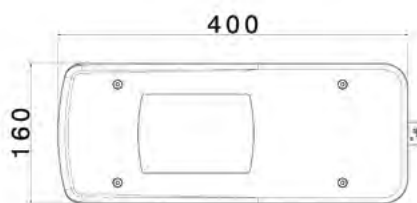

LED

ISO PULSE
13207-1



24V



14085
E2 14086 -FPL
10R-047585

Affectations constructeurs
Applicazione primo impianto
Afectación primer equipo

IVECO p. 34



160150

gauche - sinistra - izquierda



HDSCS-8P-M

latéral
connettore laterale
conector lateral



160100

droit - destra - derecha



160080

gauche - sinistra - izquierda



160090

droit - destra - derecha



160110

gauche - sinistra - izquierda



HDSCS-8P-M

arrière
connettore posteriore
conector trasero



160130

droit - destra - derecha



160140

gauche - sinistra - izquierda



160120

droit - destra - derecha



D13878

HDSCS-8P-F



060000

gauche - sinistra - izquierda



060010

droit - destra - derecha



Feux arrière - Fanali posteriori - Pilotos traseros

LC11

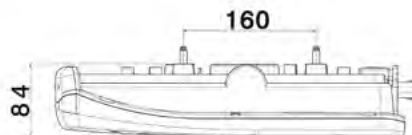
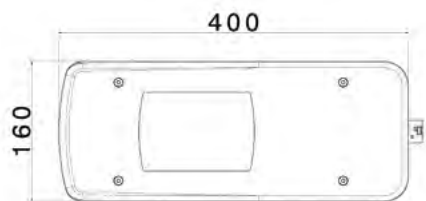

LED ISO PULSE
13207-1

12V

ADR

H

E2 14085
14086 - FPL
10R-047585

Affectations constructeurs
Applicazione primo impianto
Afectación primer equipo

[MERCEDES SPRINTER p. 56](#)



160400

gauche - sinistra - izquierda

K FPL EPP



AMP 1.5-7P-M
arrière
connettore posteriore
conector trasero



160410

droit - destra - derecha

K FPL



D11868

AMP 1.5-7P-F



060000

gauche - sinistra - izquierda

K



060010

droit - destra - derecha

K



Feux arrière - Fanali posteriori - Pilotos traseros

LC9 LED

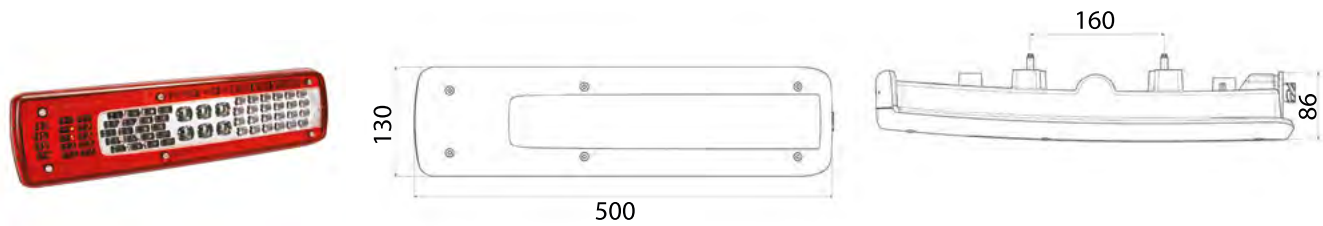

LED

24V



E2 10113
10R-036227

Affectations constructeurs
Applicazione primo impianto
Afectación primer equipo

RENAULT TRUCKS p. 63
VOLVO TRUCKS p. 101



158030



gauche - sinistra - izquierda



AMP 1.5-7P-M

latéral
connettore laterale
conector lateral



158050



droit - destra - derecha



158040



droit - destra - derecha



D11868

AMP 1.5-7P-F



058000

gauche - sinistra - izquierda



058000

droit - destra - derecha



Feux arrière - Fanali posteriori - Pilotos traseros

LC10 LED

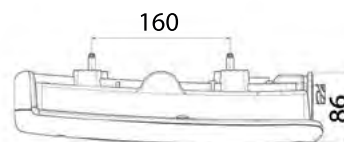
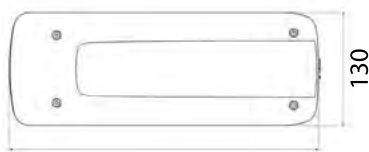

LED

24V



E2 12164
10R-036854

Affectations constructeurs
Applicazione primo impianto
Afectación primer equipo

RENAULT TRUCKS p. 63
VOLVO TRUCKS p. 101



159520

gauche - sinistra - izquierda



AMP 1.5-7P-M

latéral
connettore laterale
conector lateral



159530

droit - destra - derecha



159500

gauche - sinistra - izquierda



159510

droit - destra - derecha



D11868

AMP 1.5-7P-F



059500

gauche - sinistra - izquierda



059500

droit - destra - derecha

Feux arrière - Fanali posteriori - Pilotos traseros

CTL15



LED

24V



E₂ 16005

Affectations constructeurs
Applicazione primo impianto
Afectación primer equipo

CHEREAU p. 17
LECAPITAINE p. 48
TROUILLET p. 97

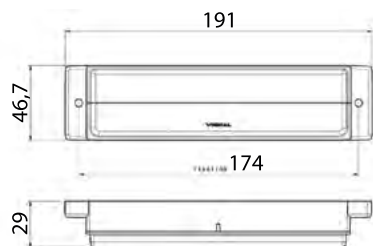

DT04-4P-M



164000

Fixation par l'arrière
Fissaggio posteriore
Fijación trasera

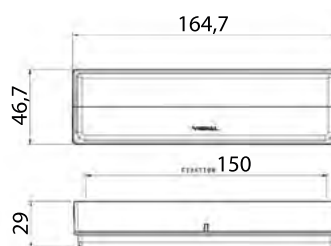

DT04-4P-M



DTM04-4P-M



164010

Pour raccordement sur feu BL15
Per collegamento su fanale BL15
Para conectar sobre piloto BL15



DT04-4P-M



164020

Fixation par l'avant
Fissaggio frontale
Fijación frontal



DT04-4P-M



DTM04-4P-M



164030

Pour raccordement sur feu BL15
Per collegamento su fanale BL15
Para conectar sobre piloto BL15

BL15



LED

24V

1200 Lumen



E₂ 16007
10R-0516079

Affectations constructeurs
Applicazione primo impianto
Afectación primer equipo

CHEREAU p. 17
FRUEHAUF p. 31
LECAPITAINE p. 48
TROUILLET p. 97

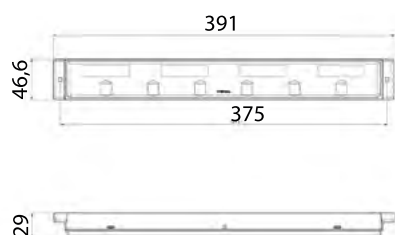

165020

gauche - sinistra - izquierda



DT04-4P-M



DTM06-4S-4P-F

Fixation par l'arrière
Fissaggio posteriore
Fijación trasera



165040

gauche - sinistra - izquierda

Fixation par l'avant
Fissaggio frontale
Fijación frontal

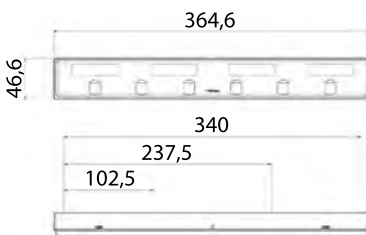

165030

droit - destra - derecha



165050

droit - destra - derecha

Feux arrière - Fanali posteriori - Pilotos traseros

CTL15 - BL15

Indicateur de direction à défilement - feux de détresse flash
 Indicatore di direzione dinamico - luci di emergenza flash
 Intermitentes dinámicos - luces de emergencia flash



Feu de travail 1200 Lumen
 Faro da lavoro 1200 Lumen
 Faro de trabajo 1200 Lumen

Stop et position
 Stop e posizione
 Stop y posición



CTL15 - BL15

LED

24V

1200 Lumen



E2
 16005
 16007
 10R-0516079

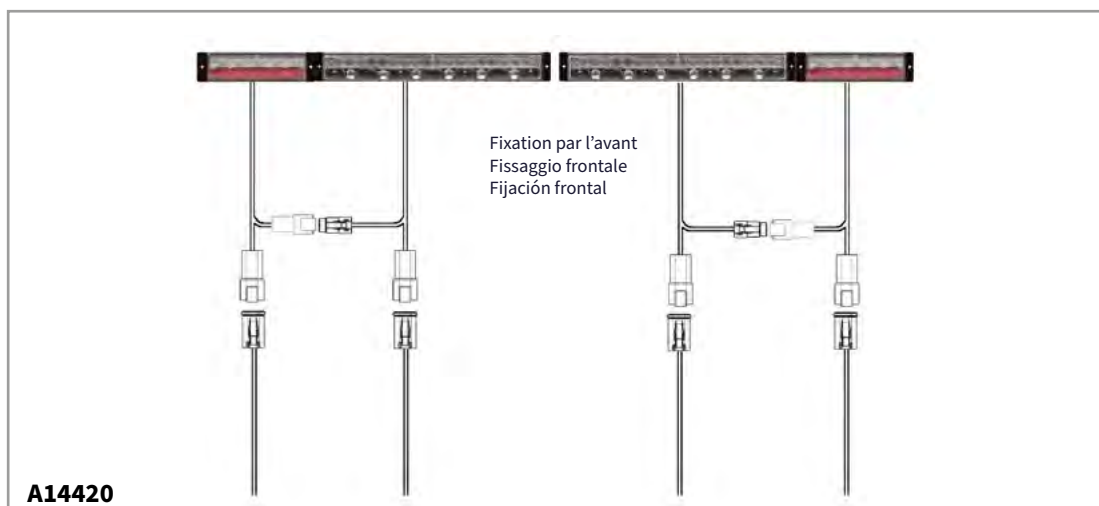

A14420

2 x CTL15 + 1 x BL15 gauche + 1 x BL15 droit + 4 câbles 8,5 m
 2 x CTL15 + 1 x BL15 sinistro + 1 x BL15 destro + 4 cavi 8,5 m
 2 x CTL15 + 1 x BL15 izquierdo + 1 x BL15 derecho + 4 cables 8,5 m

Feux arrière - Fanali posteriori - Pilotos traseros

CTL14

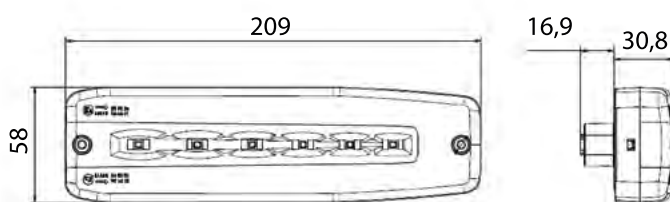

LED ISO PULSE 13207-1

12/24V



E2 16111
20056
10R-17254

NEW



DT04-4P-M
arrière
connettore posteriore
conector trasero

163010

gauche/droit - sinistra/destra - izquierda/derecha
Stop - position - clignotant dynamique
Stop - posizione - indicatore di direzione dinamico
Stop - posición - intermitente dinámico

163050

gauche/droit - sinistra/destra - izquierda/derecha
Stop - position - recul
Stop - posizione - retromarcia
Stop - posición - marcha atrás



D14436 DT06-4S-4P-F

SESA SOLAR

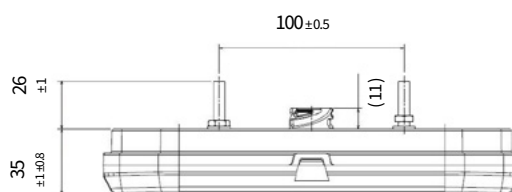
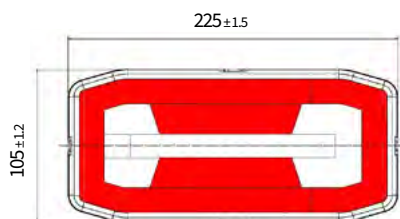

LED

12V



E9 14261
10R-4974

IP69K

NEW



AMP 1.5-7P-M
arrière
connettore posteriore
conector trasero

D15056
(F SMR)

K

gauche/droit - sinistra/destra - izquierda/derecha
Stop - position - clignotant - recul - antibrouillard
Stop - posizione - indicatore di direzione - retromarcia - antinebbia
Stop - posición - intermitente - marcha atrás - antiniebla



Clignotant dynamique ou statique
Indicatore di direzione dinamico o statico
Intermitente dinámico o estática

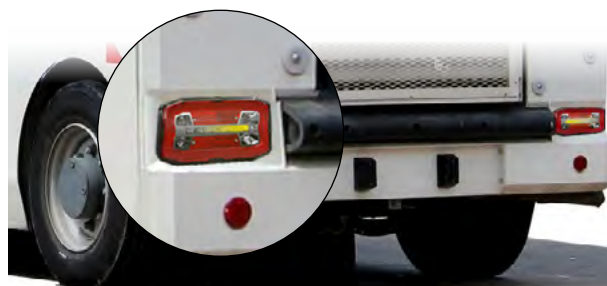

SESA AIRGLOW

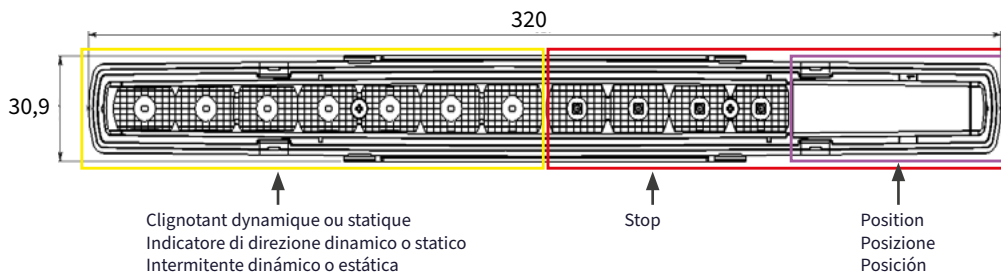

LED

12/24V



E9 14260
10R-4955

IP69K

NEW



D16006
(FSAG.UPSPC)

SS-5P-M

gauche/droit - sinistra/destra - izquierda/derecha

SLIM

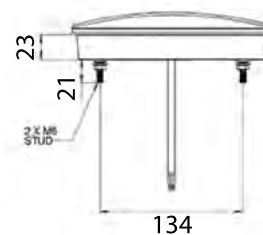
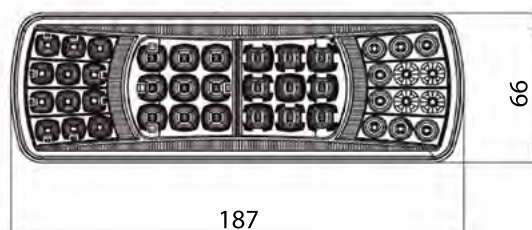

LED

12/24V



E9 11734
10R-051614

* fils nus - estremità cavo nuda - cable pelado

D13817*

gauche/droit - sinistra/destra - izquierda/derecha



F930



NEW

LED IP67

12/24V



E1 3110
10R-0310354



D16011*
(F930)

gauche/droit - sinistra/destra - izquierda/derecha

* fils nus - estremità cavo nuda - cable pelado

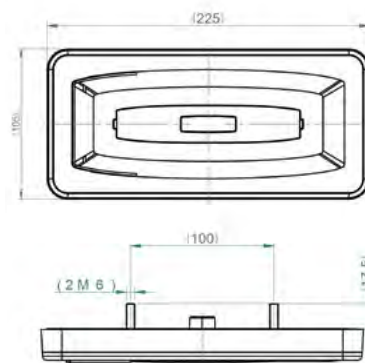

Feux arrière - Fanali posteriori - Pilotos traseros

FRR

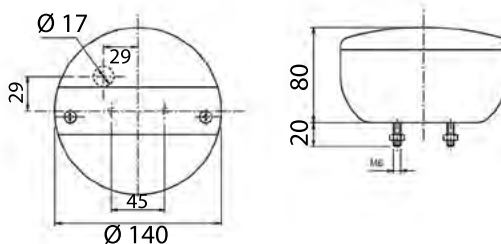

LED

12/24V



E4 13992
23271
4052



IP67

* cosses plates - connettori a spina piatta - vainas planas



D13816 *

gauche/droit - sinistra/destra - izquierda/derecha
Stop - position - clignotant
Stop - posizione - indicatore di direzione
Stop - posición - intermitente



D14189 *

feu de recul
luce di retromarcia
piloto marcha atrás



D14188 *

feu de brouillard
luce retronebbia
piloto antiniebla

FRR

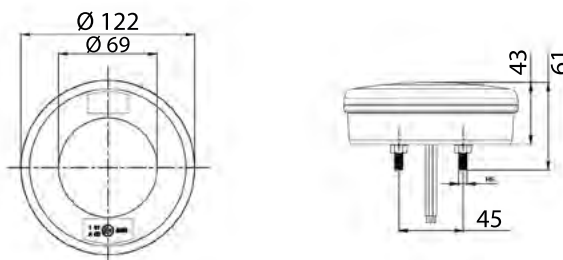

LED

12/24V



E9 6653
1288
10R-041489
10R-041487



IP67

* fils nus - estremità cavo nuda - cable pelado



D14348*

gauche/droit - sinistra/destra - izquierda/derecha
Stop - position - clignotant
Stop - posizione - indicatore di direzione
Stop - posición - intermitente



D14345*

feu de recul - brouillard
luce di retromarcia - retronebbia
piloto marcha atrás - antiniebla

KIT WIRELESS MAGNETIC

LED

12/24V

H

IP67

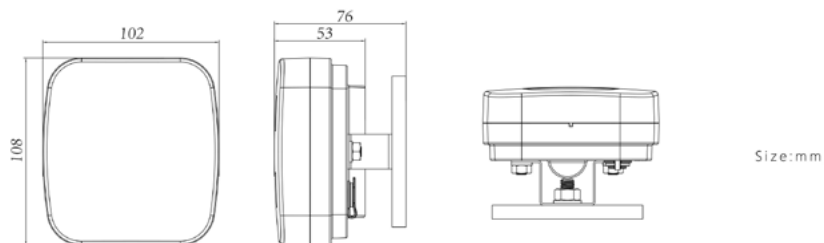

NEW



D16089
(SAR70KITEA9800W)

gauche/droit - sinistra/destra - izquierda/derecha



LED Wireless Control

STOP



LED

12/24V

H

E₂₀ 0021276
10R-052819

IP67

NEW



D16029*
(66L682)

Stop

* fils nus - estremità cavo
nuda - cable pelado

Feux arrière - Fanali posteriori - Pilotos traseros

LC8

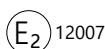
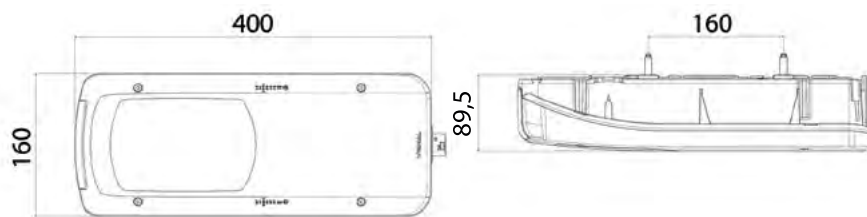

Affectations constructeurs
Applicazione primo impianto
Afectación primer equipo

DAF p. 20



155100

gauche - sinistra - izquierda



HDSCS-8P-M

latéral
connettore laterale
conector lateral



155110

droit - destra - derecha



155120

droit - destra - derecha



155130

gauche - sinistra - izquierda



HDSCS-8P-M

arrière
connettore posteriore
conector trasero



155140

droit - destra - derecha



155150

droit - destra - derecha



D13878

HDSCS-8P-F



055020

gauche - sinistra - izquierda



055030

droit - destra - derecha



001830



Feux arrière - Fanali posteriori - Pilotos traseros

LC8

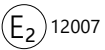
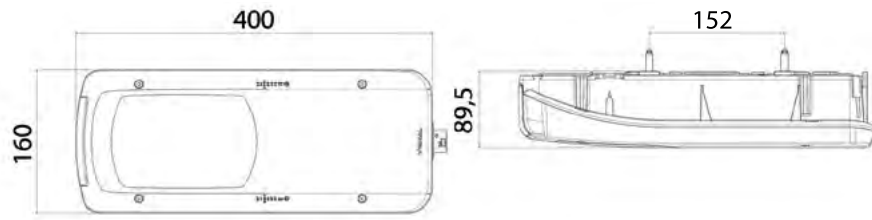

Affectations constructeurs
Applicazione primo impianto
Afectación primer equipo

VOLKSWAGEN CRAFTER p. 100



155570

gauche - sinistra - izquierda



AMP 1.5-7P-M

arrière
connettore posteriore
conector trasero



155580

droit - destra - derecha



D11868

AMP 1.5-7P-F



055020

gauche - sinistra - izquierda



055030

droit - destra - derecha



Feux arrière - Fanali posteriori - Pilotos traseros

LC8

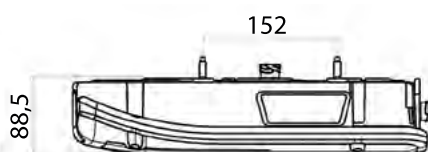
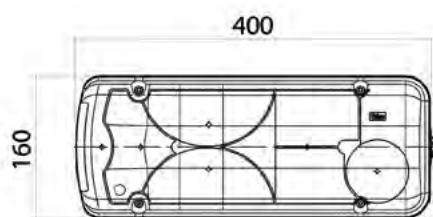

Affectations constructeurs
Applicazione primo impianto
Afectación primer equipo

IVECO p. 34

DESIGN EFFET FUMÉ - MÉTALLISÉ
DESIGN METALLIZZATO - FUMATO
DISEÑO EFECTO AHUMADO - METALIZADO



155450

gauche - sinistra - izquierda



HDSCS-8P-M

latéral
connettore laterale
conector lateral



155460

droit - destra - derecha



155470

droit - destra - derecha



155480

gauche - sinistra - izquierda



HDSCS-8P-M

arrière
connettore posteriore
conector trasero



155490

droit - destra - derecha



155540

gauche - sinistra - izquierda



155500

droit - destra - derecha



D13878

HDSCS-8P-F



055040

gauche - sinistra - izquierda



055050

droit - destra - derecha



001830



Feux arrière - Fanali posteriori - Pilotos traseros

LC8

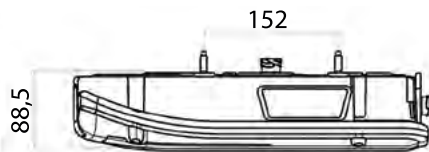
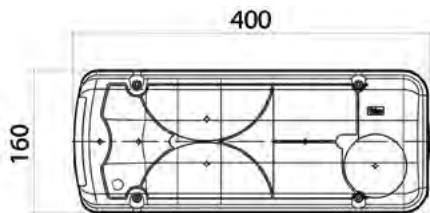

Affectations constructeurs
Applicazione primo impianto
Afectación primer equipo

MAN p. 52



156200

gauche - sinistra - izquierda



AMP 1.5-7P-M

latéral
connettore laterale
conector lateral

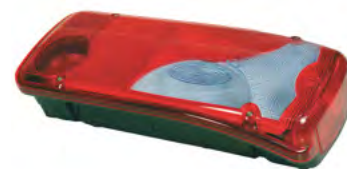

156210

droit - destra - derecha



001872 55-90 db



156220

droit - destra - derecha



Affectations constructeurs
Applicazione primo impianto
Afectación primer equipo

MAN (TGE) p. 52

* vis arrière de 31 mm
* viti posteriori di 31 mm
* tornillos traseros de 31 mm



155550 *

12V

gauche - sinistra - izquierda



AMP 1.5-7P-M

arrière
connettore posteriore
conector trasero



155560 *

12V

droit - destra - derecha



D11868

AMP 1.5-7P-F



056500

gauche - sinistra - izquierda



056510

droit - destra - derecha



Feux arrière - Fanali posteriori - Pilotos traseros

LC8

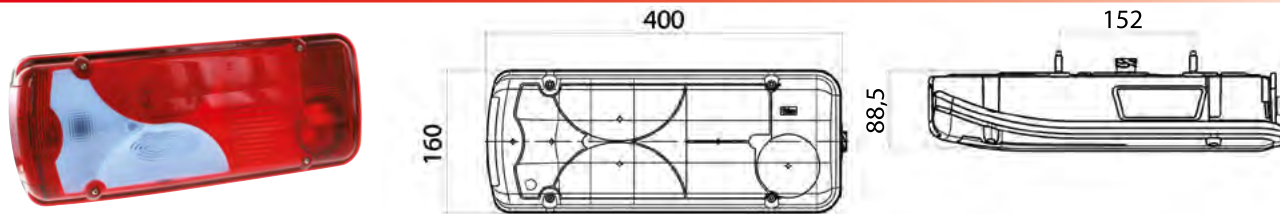

ADR

H

E₂ 2040

Affectations constructeurs
Applicazione primo impianto
Afectación primer equipo

CHEREAU p. 17
LAMBERET p. 44



156550

gauche - sinistra - izquierda

FPL



AMP 1.5-7P-M

arrière
connettore posteriore
conector trasero

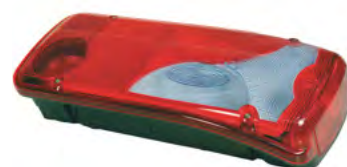

156540

droit - destra - derecha

FPL



156310

gauche - sinistra - izquierda

K FPL

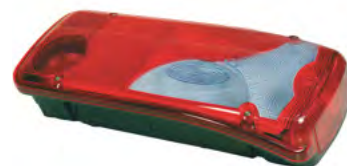

156300

droit - destra - derecha

K FPL



156290

gauche - sinistra - izquierda

K FPL EPP



D11868

AMP 1.5-7P-F



056000

056500

gauche - sinistra - izquierda

K

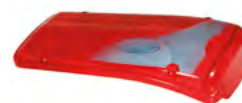

056010

056510

droit - destra - derecha

K

Feux arrière - Fanali posteriori - Pilotos traseros

LC8

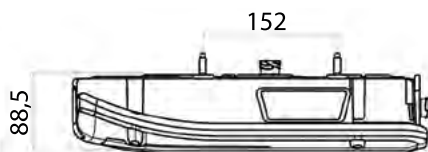
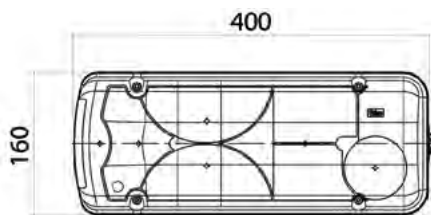

Affectations constructeurs
Applicazione primo impianto
Afectación primer equipo

SCANIA p. 91



156770 K FPL EPP
gauche - sinistra - izquierda



AMP 1.5-7P-M
latéral
connettore laterale
conector lateral



156780 K FPL
droit - destra - derecha



155020 K FPL
gauche - sinistra - izquierda



156790 K FPL Speaker
droit - destra - derecha



155080 K FPL EPP
gauche - sinistra - izquierda



AMP 1.5-7P-M
arrière
connettore posteriore
conector trasero



155520 K FPL
droit - destra - derecha



155090 K FPL Speaker
droit - destra - derecha



D11868 **AMP 1.5-7P-F**



056540 K
gauche - sinistra - izquierda



056550 K
droit - destra - derecha



001830 Speaker

Feux arrière - Fanali posteriori - Pilotos traseros

LC8

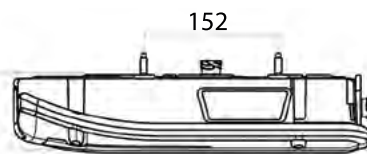
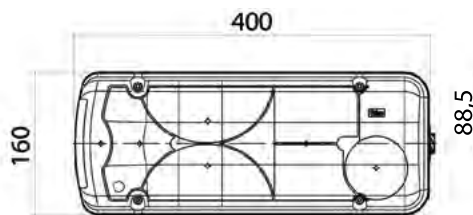

Affectations constructeurs
Applicazione primo impianto
Afectación primer equipo

MERCEDES p. 55
VOLKSWAGEN p. 100



156590

gauche - sinistra - izquierda



AMP 1.5-7P-M

arrière
connettore posteriore
conector trasero



156600

droit - destra - derecha



156340

gauche - sinistra - izquierda



156350

droit - destra - derecha



D11868

AMP 1.5-7P-F



056020

056540

gauche - sinistra - izquierda



056030

056550

droit - destra - derecha



Feux arrière - Fanali posteriori - Pilotos traseros

LC8T

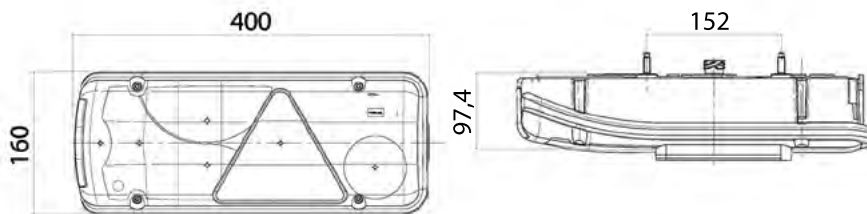

Affectations constructeurs
Applicazione primo impianto
Afectación primer equipo

ALMAJDOUIE p. 8
ASCA p. 10
BENALU GROUP p. 14
CHEREAU p. 17
FRUEHAUF p. 31
LAMBERET p. 44
SOR IBERICA p. 95



156040

gauche - sinistra - izquierda



AMP 1.5-7P-M

arrière
connettore posteriore
conector trasero



156050

droit - destra - derecha



156060

gauche - sinistra - izquierda



156070

droit - destra - derecha



Repiquage fonctions stop et positions Collegamento funzioni stop e posizioni Empalme funciones stop y posición

Pour - Per - Para :
156040 - 156050 - 156060 - 156070 - 156130 - 156170
- 156250 - 156260 - 156290 - 156300 - 156310 - 156380 -
156390 - 156540 - 156550 - 156590 - 156600
Câblage - Cablaggio - Cableado p. 270



156130

droit - destra - derecha



156630

gauche - sinistra - izquierda



AMP 1.5-7P-M

latéral
connettore laterale
conector lateral



156640

droit - destra - derecha



D11868

AMP 1.5-7P-F



056700

gauche - sinistra - izquierda



056710

droit - destra - derecha



001830



Feux arrière - Fanali posteriori - Pilotos traseros

LC8T

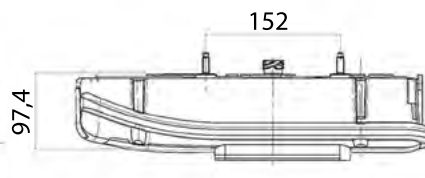
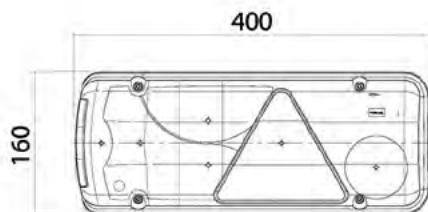

Affectations constructeurs
Applicazione primo impianto
Afectación primer equipo

FELDBINDER p. 27
LECIÑENA p. 49



156250

gauche - sinistra - izquierda



AMP 1.5-7P-M

arrière
connettore posteriore
conector trasero



156260

droit - destra - derecha



156380

gauche - sinistra - izquierda



156390

droit - destra - derecha



D11868

AMP 1.5-7P-F



056720

gauche - sinistra - izquierda



056730

droit - destra - derecha



12/24V



D14038

500 mm

gauche - sinistra - izquierda

CLICK-IN



D14037

500 mm

droit - destra - derecha

CLICK-IN



D14039

350 mm

gauche - sinistra - izquierda

POS-2P-F



D14040

350 mm

droit - destra - derecha

POS-2P-F



W5W



12/24V



D13034

500 mm

gauche - sinistra - izquierda

CLICK-IN



D13035

500 mm

droit - destra - derecha

CLICK-IN



D12712

350 mm

gauche - sinistra - izquierda

POS-2P-F



D12711

350 mm

droit - destra - derecha

POS-2P-F



Catadiopre
Catarifrangente
Catadióptico



Catadiopre triangulaire
Triangolo carifrangente
Catadióptico triangular



Feu de position latéral
Luce di posizione laterale
Piloto de posición lateral



Eclairer de plaque
Luce targa
Iluminación de placa



Alarme sonore de recul
Cicalino di ritromarcia
Alarma sonora de marcha atrás

Feux arrière - Fanali posteriori - Pilotos traseros

LC9

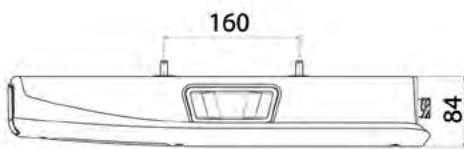
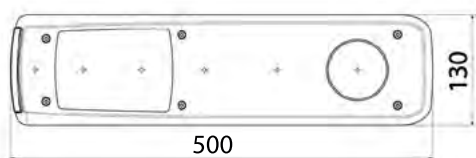

E₂ 04075

Affectations constructeurs
Applicazione primo impianto
Afectación primer equipo

RENAULT TRUCKS p. 63
VOLVO TRUCKS p. 101



159010

gauche - sinistra - izquierda



AMP 1.5-7P-M
latéral
connettore laterale
conector lateral



159020

droit - destra - derecha



159030

droit - destra - derecha



D11868 AMP 1.5-7P-F



059000

gauche - sinistra - izquierda



059000

droit - destra - derecha



D12953



Feux arrière - Fanali posteriori - Pilotos traseros

LC15

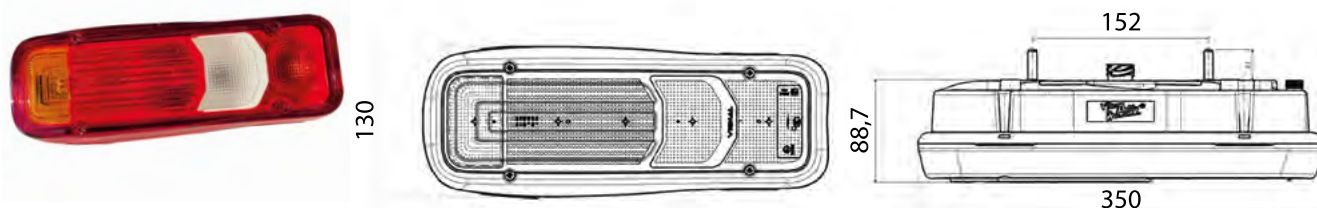

E₂ 21003

Affectations constructeurs
Applicazione primo impianto
Afectación primer equipo

IVECO p. 41

NEW



154200



gauche - sinistra - izquierda



AMP 1.5-7P-M

arrière
connettore posteriore
conector trasero

NEW



154210



droit - destra - derecha

NEW



154220



gauche - sinistra - izquierda

NEW



154220



droit - destra - derecha



D11868

AMP 1.5-7P-F



053730



gauche - sinistra - izquierda



053730



droit - destra - derecha



Feux arrière - Fanali posteriori - Pilotos traseros

LC5

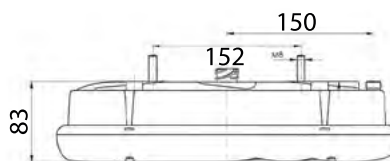
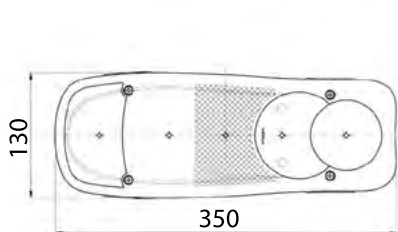

E₂ 8005

Affectations constructeurs
Applicazione primo impianto
Afectación primer equipo

DAF p. 20
IVECO p. 34
NISSAN p. 58
OPEL p. 61
RENAULT TRUCKS p. 63
VOLKSWAGEN p. 100
VOLVO TRUCKS p. 101



152130

152150

gauche - sinistra - izquierda



PG 13

arrière
connettore posteriore
conector trasero



152130

152150

droit - destra - derecha



152160

152140

gauche - sinistra - izquierda



AMP 1.5-7P-M

arrière
connettore posteriore
conector trasero



152200

152180

droit - destra - derecha



152190

152170

gauche - sinistra - izquierda



153120

droit - destra - derecha



D11868

AMP 1.5-7P-F



052000

052500

gauche - sinistra - izquierda



052000

052500

droit - destra - derecha

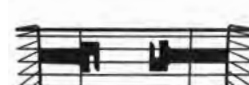

D13288

grille de protection réversible
homologuée - Griglia approvata -
Rejilla homologada

Feux arrière - Fanali posteriori - Pilotos traseros

LC5

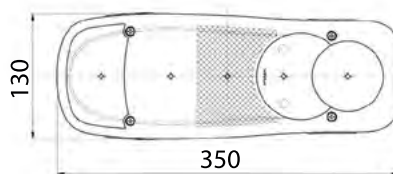

E₂ 8005

Affectations constructeurs
Applicazione primo impianto
Afectación primer equipo

FIAT p. 29
PEUGEOT CITROËN p. 62



153270

gauche - sinistra - izquierda



AMP 1.5-7P-M

arrière
connettore posteriore
conector trasero



153280

droit - destra - derecha



D11868

AMP 1.5-7P-F



052500

gauche - sinistra - izquierda



052500

droit - destra - derecha



Fixation 4 vis M6 (190x60mm)
Fijación 4 tornillos M6 (190x60mm)
4 vite di fissaggio M6 (190x60mm)



Feux arrière - Fanali posteriori - Pilotos traseros

LC5

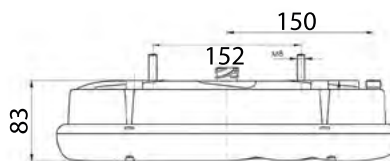
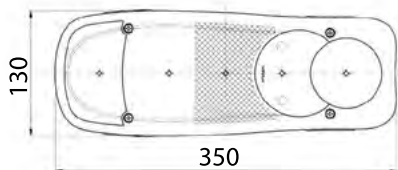

Affectations constructeurs
Applicazione primo impianto
Afectación primer equipo

IVECO p. 36



153220

gauche - sinistra - izquierda



AMP 1.5-7P-M

arrièr
connettore posteriore
conector trasero



153210

droit - destra - derecha



153200

gauche - sinistra - izquierda



153230

droit - destra - derecha



153240

gauche - sinistra - izquierda



153250

droit - destra - derecha



D11868

AMP 1.5-7P-F



052500

gauche - sinistra - izquierda



052500

droit - destra - derecha



Feux arrière - Fanali posteriori - Pilotos traseros

LC5T

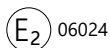
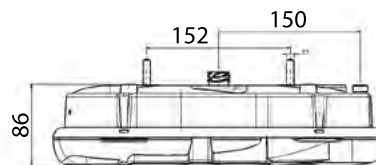
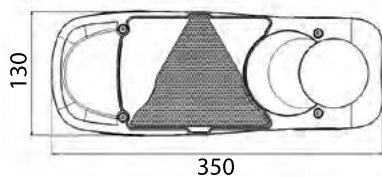

Affectations constructeurs
Applicazione primo impianto
Afectación primer equipo

ASCA p. 8
LAMBERET p. 44
LECIÑENA p. 49



153040

gauche - sinistra - izquierda



PG 13

arrière
connettore posteriore
conector trasero



153050

droit - destra - derecha



153060

gauche - sinistra - izquierda



153070

droit - destra - derecha



153000

gauche - sinistra - izquierda



AMP 1.5-7P-M

arrière
connettore posteriore
conector trasero



153010

droit - destra - derecha



153130

droit - destra - derecha



153020

gauche - sinistra - izquierda



153030

droit - destra - derecha



D11868

AMP 1.5-7P-F



053700

gauche - sinistra - izquierda



053710

droit - destra - derecha



Feux arrière - Fanali posteriori - Pilotos traseros

LC5TDX

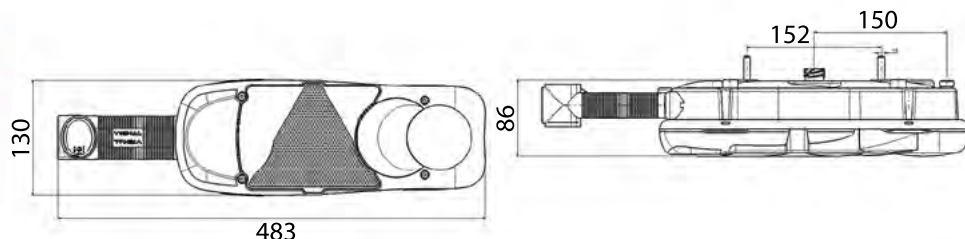

E₂ 06024 (sans DX)
07092 (avec DX)

Affectations constructeurs
Applicazione primo impianto
Afectación primer equipo

ASCA p. 10



AMP 1.5-7P-M
arrière
connettore posteriore
conector trasero



153660



153700



gauche - sinistra - izquierda

153670



153710



droit - destra - derecha



D11868

AMP 1.5-7P-F



053700



gauche - sinistra - izquierda



053710



droit - destra - derecha



D12430

LC7

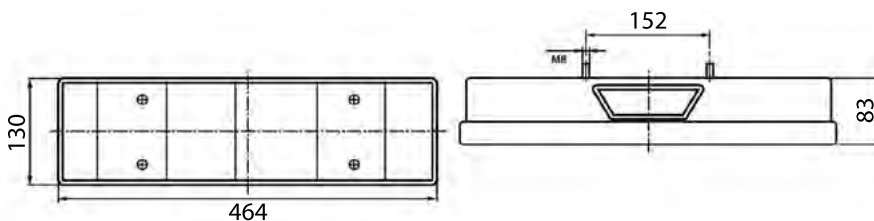

E₂ 88035 (LC7K)

Affectations constructeurs
Applicazione primo impianto
Afectación primer equipo

MAN p. 54



DIN 72480-8P-M
arrière
connettore posteriore
conector trasero



168090



gauche - sinistra - izquierda

168090



droit - destra - derecha



168100



gauche - sinistra - izquierda



067500



gauche - sinistra - izquierda



067500



droit - destra - derecha

Feux arrière - Fanali posteriori - Pilotos traseros

LC7

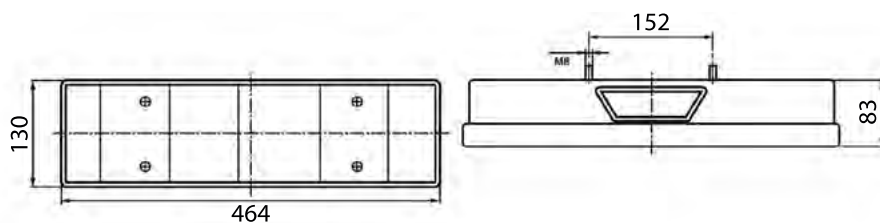

E2 88017 (LC7)
88035 (LC7K)

Affectations constructeurs
Applicazione primo impianto
Afectación primer equipo

RENAULT TRUCKS p. 68



167100



167600



gauche - sinistra - izquierda



PE
arrière
connettore posteriore
conector trasero



167000

167500



droit - destra - derecha



168270



gauche - sinistra - izquierda



168270



droit - destra - derecha



168340



gauche - sinistra - izquierda



067000

067500



067000

067500

gauche - sinistra - izquierda

droit - destra - derecha

Affectations constructeurs
Applicazione primo impianto
Afectación primer equipo

DAF p. 20
MAN p. 52



169180



gauche - sinistra - izquierda



AMP 1.5-7P-M
latéral
connettore laterale
conector lateral



169170



169190



droit - destra - derecha



169160



gauche - sinistra - izquierda



D11868

AMP 1.5-7P-F



Feux arrière - Fanali posteriori - Pilotos traseros

LC7

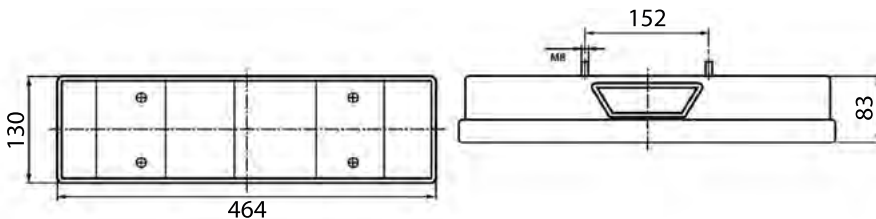

E₂ 88035 (LC7K)

Affectations constructeurs
Applicazione primo impianto
Afectación primer equipo

IVECO p. 38

EURO 5



168590

gauche - sinistra - izquierda



IVECO
arrière
connettore posteriore
conector trasero



168600

droit - destra - derecha



168610

gauche - sinistra - izquierda



168480

droit - destra - derecha



Affectations constructeurs
Applicazione primo impianto
Afectación primer equipo

IVECO p. 37

EURO 6



169390

gauche - sinistra - izquierda



DIN 72480-8P-M
arrière
connettore posteriore
conector trasero



169410

droit - destra - derecha



169400

gauche - sinistra - izquierda



169420

droit - destra - derecha



067500

gauche - sinistra - izquierda



067500

droit - destra - derecha



D12953



Feux arrière - Fanali posteriori - Pilotos traseros

LC7

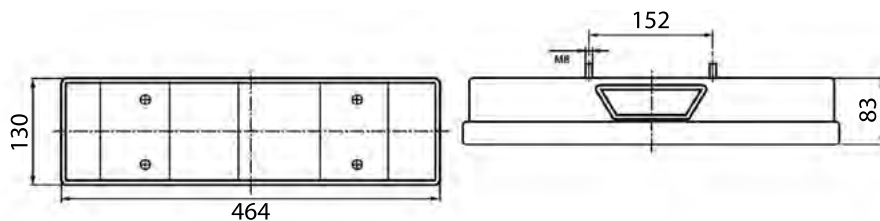

E₂ 88035 (LC7K)

Affectations constructeurs
Applicazione primo impianto
Afectación primer equipo

DAF p. 20



168020



gauche - sinistra - izquierda



DAF
arrière
connettore posteriore
conector trasero



168010



droit - destra - derecha



067500



gauche - sinistra - izquierda



067500



droit - destra - derecha

LC7

MILITARY



168810



gauche - sinistra - izquierda

15P-M

arrière
connettore posteriore
conector trasero



168810



droit - destra - derecha

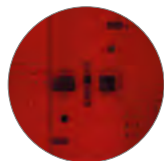

Blackout position + stop



Feux arrière - Fanali posteriori - Pilotos traseros

LC7T

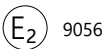
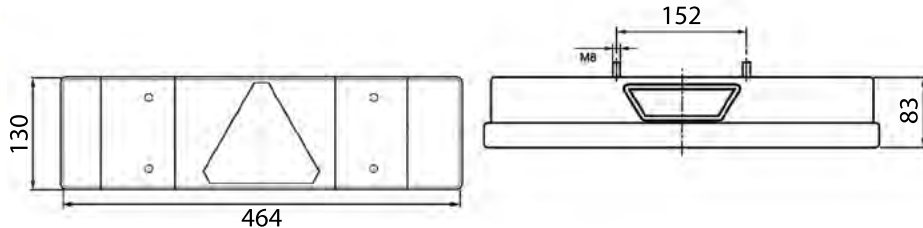

167530



168770



gauche - sinistra - izquierda



PE
arrière
connettore posteriore
conector trasero



167550



168790



droit - destra - derecha



168780



gauche - sinistra - izquierda



168800



droit - destra - derecha



067610



gauche - sinistra - izquierda



067600



droit - destra - derecha



168830



droit - destra - derecha

LC6

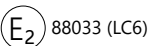
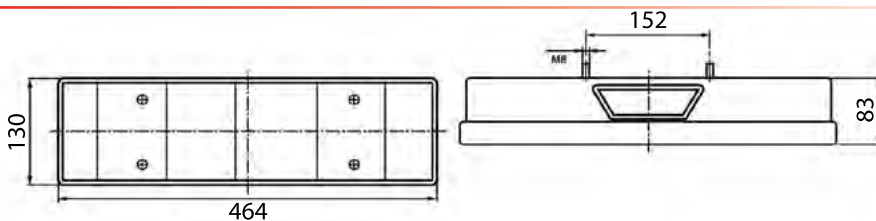

166000

166100



gauche - sinistra - izquierda



PE
arrière
connettore posteriore
conector trasero



166000

166100



droit - destra - derecha



066000

gauche - sinistra - izquierda



066000

droit - destra - derecha

Affectations constructeurs
Applicazione primo impianto
Afectación primer equipo

RENAULT TRUCKS p. 63

Feux arrière - Fanali posteriori - Pilotos traseros

LC4

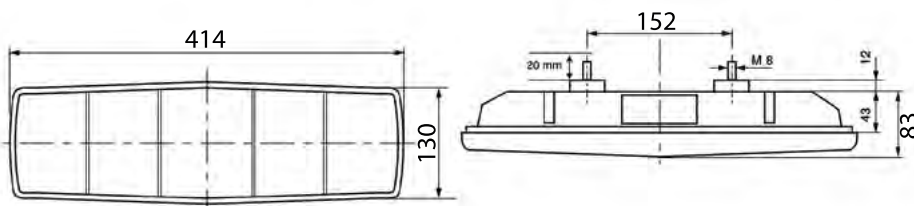

E₂ 91098 (LC4)
91099 (LC4K)

Affectations constructeurs
Applicazione primo impianto
Afectación primer equipo

RENAULT TRUCKS p. 75



141000

gauche - sinistra - izquierda



PE
arrière
connettore posteriore
conector trasero



141000

droit - destra - derecha



141500

gauche - sinistra - izquierda



141500

droit - destra - derecha



040000

040500

gauche - sinistra - izquierda



040000

040500

droit - destra - derecha



Feux arrière - Fanali posteriori - Pilotos traseros

UNISTOP



E9 11004

Affectations constructeurs
Applicazione primo impianto
Afectación primer equipo

FORD p. 30

* fils nus - estremità cavo
nuda - cable pelado

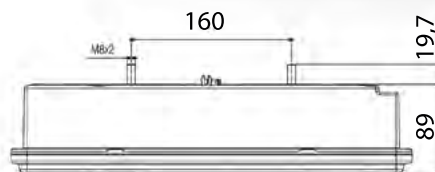
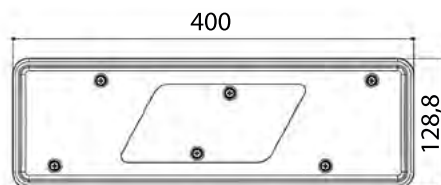

NEW



D16109*



gauche - sinistra - izquierda

NEW



D16108*



droit - destra - derecha

WARNING SIGNAL



1710
1711
E20 10R-4184
10R-4185



IP67

* fils nus - estremità cavo
nuda - cable pelado

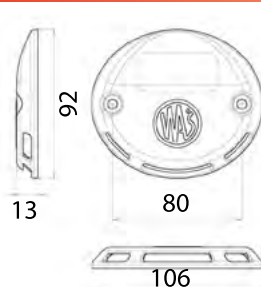

NEW



D16024
(66L1126)

NEW



D16025
(66L1127)



Feux arrière - Fanali posteriori - Pilotos traseros

725



E13 8434

Affectations constructeurs
Applicazione primo impianto
Afectación primer equipo

IVECO p. 42

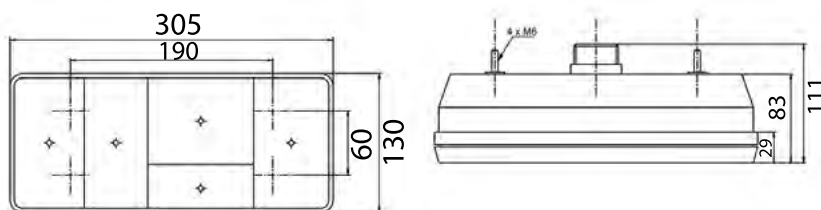

D11482

gauche - sinistra - izquierda



AMP 1.5-5P-M

arrière
connettore posteriore
conector trasero



D11481

droit - destra - derecha



D11868

AMP 1.5-7P-F



D11480

gauche - sinistra - izquierda



D11479

droit - destra - derecha



E13 2060

Affectations constructeurs
Applicazione primo impianto
Afectación primer equipo

IVECO p. 41



D12334

gauche - sinistra - izquierda



AMP 1.5-6P-M

arrière
connettore posteriore
conector trasero



D12335

droit - destra - derecha



D11868

AMP 1.5-7P-F



D12336

gauche - sinistra - izquierda



D12337

droit - destra - derecha



Eclaireurs de plaque

Luci targa

Iluminación de placa

WWW.VIGNAL-GROUP.COM

LED

p. 150-151



Halogène

p. 152



SS-2P-F

Type connecteur - Nb pins - Mâle ou Femelle
Tipo di connettore - Num pin - Maschio o Femmina
Tipo de conector - Num pines - macho o hembra



Flashez le QR code pour plus d'infos
Scansiona il codice QR per maggiori informazioni
Escanee el código QR para obtener más info



Pièces détachées
Ricambi
Repuestos



Numéro d'homologation
Numero di omologazione
Número de aprobación



Sens de montage
Direzione di montaggio
Dirección de montaje



Faisceau p. 269
Cablaggio p. 269
Cableado p. 269

LPL18

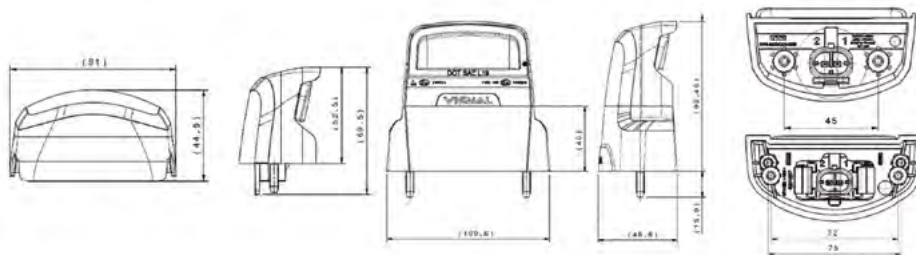

12/24V



E₂ 19014
10R-19224



199020

SS-2P-M

Entraxe 72 mm
Distanza del bullone di fissaggio 72 mm
Distancia entre tornillos 72 mm



199030

SS-2P-M

Entraxe 75 mm
Distanza del bullone di fissaggio 75 mm
Distancia entre tornillos 75 mm

1 seul feu LED par plaque
1 luce LED per targa
1 luz LED por placa



199020
199030

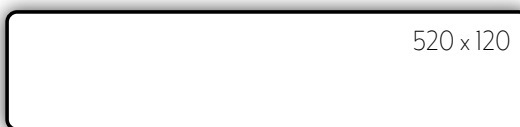

520 x 120

Affectations constructeurs
Applicazione primo impianto
Afectación primer equipo

ALAMJDOUIE p.8
BENALU GROUP p. 14
LAMBERET p. 44
VAK OY p. 99



199000

SS-2P-M

clippé - fissaggio con clip - fijación con clip



199040

SS-2P-M

Entraxe 45 mm
Distanza del bullone di fissaggio 45 mm
Distancia entre tornillos 45 mm

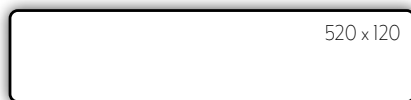

520 x 120

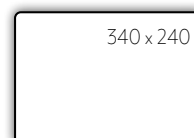

340 x 240

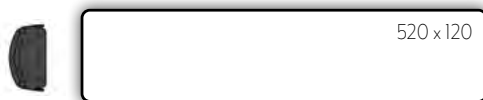

520 x 120

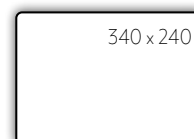

340 x 240

Plus d'implantations sur notre site web.
Più installazioni sul nostro sito web.
Más posicionamiento en nuestra web



D13880

SS-2P-F



D14985

SS-2P-F



Eclaireurs de plaque - Luci targa - Iluminación de placa

EPP96 LED



LED

24V

ADR



E₂ 11017

Affectations constructeurs
Applicazione primo impianto
Afectación primer equipo

ASCA p. 10
DE BUF p. 25
FRUEHAUF p. 31
GROSSE EQUIPEMENT p. 33
LAMBERET p. 44
OMEPS p. 59
SOR IBERICA p. 95

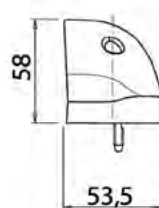
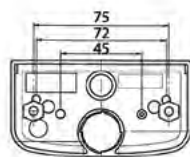
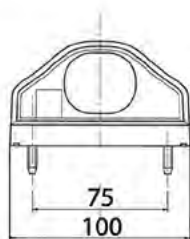

D13609 400 mm

D13610 1500 mm



R14364 2000 mm

2V Superseal
Pour / Per / Para LC12T



D13874 2000 mm

2 voies - 2 vie - 2 vías
Pour / Per / Para LC8



BX868



LED

12/24V

E₁₃ 10989

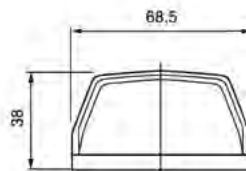
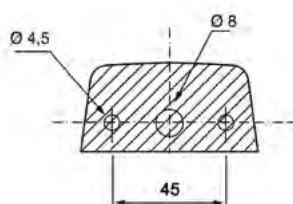

D14116 300 mm

EPP96/98



R10W



12/24V

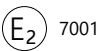

Affectations constructeurs
Applicazione primo impianto
Afectación primer equipo

ASCA p. 10
CHEREAU p. 17
FRUEHAUF p. 31
LAMBERET p. 44
MERCEDES p. 55
RENAULT TRUCKS p. 63
SOR IBERICA p. 95

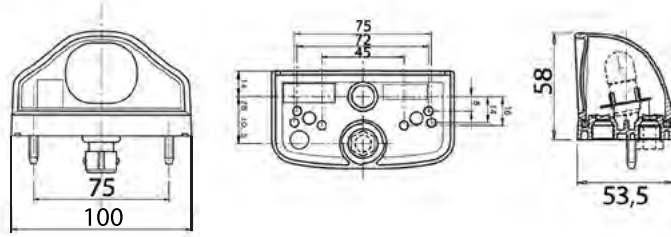

196020



000176



CLICK-IN

D10502

410 mm

D11888

1000 mm



HDSCS-3P-M

196170

500 mm



POS-2P-F

D10227

700 mm

2 voies - 2 vie - 2 vías
Pour / Per / Para LC8



Affectations constructeurs
Applicazione primo impianto
Afectación primer equipo

DAF p. 20
OPEL p. 61
RENAULT TRUCKS p. 63
UD TRUCKS p. 98
VOLVO TRUCKS p. 100



196010

JPT-2P-M



D13876

JPT-2P-F



280009

JPT-2P-F

2 m

2751



C5W



12/24V

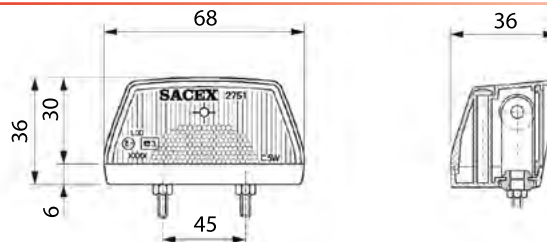

D14517

(27.51.090.VLG)

Feux clignotants

Luci intermittenti

Pilotos intermitentes

Face avant - Parte anteriore - Parte delantera

p. 154

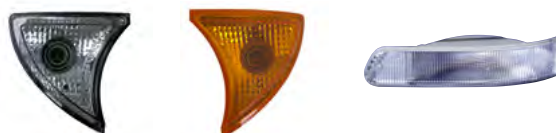

Face avant - Parte laterale - Parte lateral

p. 155-158



JPT-2P-F

Type connecteur - Nb pins - Mâle ou Femelle
Tipo di connettore - Num pin - Maschio o Femmina
Tipo de conector - Num pines - macho o hembra



Flashez le QR code pour plus d'infos
Scansiona il codice QR per maggiori informazioni
Escanee el código QR para obtener más info



Pièces détachées
Ricambi
Repuestos



Numéro d'homologation
Numero di omologazione
Número de aprobación

Feux clignotants - Luci intermittenti - Pilotos intermitentes

C105



P21W



06018
12056

Affectations constructeurs
Applicazione primo impianto
Afectación primer equipo

IVECO p. 34



PY21W



110520

gauche - sinistra - izquierda



110530

droit - destra - derecha



110550

gauche - sinistra - izquierda



110560

droit - destra - derecha



001619

C199



PY21W



0050

Affectations constructeurs
Applicazione primo impianto
Afectación primer equipo

IVECO p. 34



119920

gauche - sinistra - izquierda



119930

droit - destra - derecha

FLASHER UNIT



014580

Renault 5010149149
5 lampes, centrale clignotante
5 luci, lampeggiatore
5 lamparas, unidad intermitente



SRD08



LED

24V

E₂ 10073

Affectations constructeurs
Applicazione primo impianto
Afectación primer equipo

VOLVO TRUCKS p. 101



111000

gauche - sinistra - izquierda



111010

droit - destra - derecha



111020

gauche - sinistra - izquierda



111030

droit - destra - derecha

SRD07



LED

24V

E₂ 08028

Affectations constructeurs
Applicazione primo impianto
Afectación primer equipo

VOLVO TRUCKS p. 101



107000

gauche - sinistra - izquierda



107010

droit - destra - derecha



107040

gauche - sinistra - izquierda



107050

droit - destra - derecha



107500

gauche - sinistra - izquierda



107510

droit - destra - derecha

Feux clignotants - Luci intermittenti - Pilotos intermitentes

ICDL15



P21W



16059



120000

Affectations constructeurs
Applicazione primo impianto
Afectación primer equipo

UD TRUCKS p. 98

ICDL10



PY21W



11128



117000

gauche - sinistra - izquierda



117010

droit - destra - derecha

Affectations constructeurs
Applicazione primo impianto
Afectación primer equipo

DAF p. 20



001619

ICDL07



PY21W



09025



109010

Affectations constructeurs
Applicazione primo impianto
Afectación primer equipo

DAF p. 20



ICDL94



E2 5047 (R5W)
7139 (P21W)

Affectations constructeurs
Applicazione primo impianto
Afectación primer equipo

DAF p. 20
IVECO p. 34
NISSAN p. 58
RENAULT TRUCKS p. 63
VOLVO TRUCKS p. 101

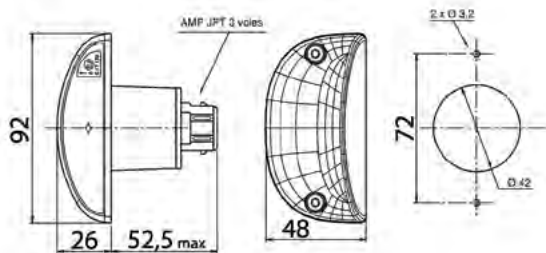

R5W

119450



119550



P21W

119470



D13877

JPT-2P-F



001616

JPT-2P-M

Feux clignotants - Luci intermittenti - Pilotos intermitentes

FE87



C5W



4703

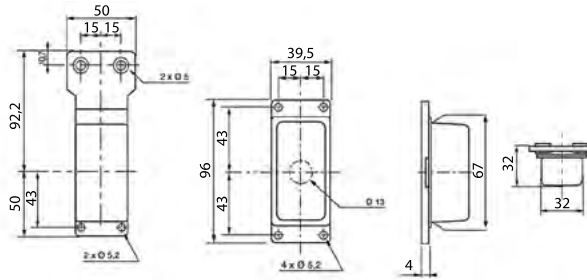

187140



187760



087040

cabochon - lente - tulipa

FE81



T4W



90711

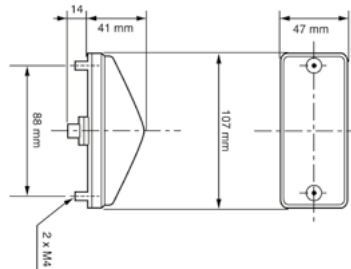

181050



000086

Feux de position

Luci di posizione

Pilotos de posición



Face avant - Parte anteriore - Parte delantera

p. 160-164



Face latérale - Parte laterale - Parte lateral

p. 165-169



Face arrière - Parte posteriore - Parte trasera

p. 170-172



Flashez le QR code pour plus d'infos
Scansiona il codice QR per maggiori informazioni
Escanee el código QR para obtener más info



Pièces détachées
Ricambi
Repuestos



Numéro d'homologation
Numero di omologazione
Número de aprobación



Sens de montage
Direzione di montaggio
Dirección de montaje

DT-2P-M

Type connecteur - Nb pins - Mâle ou Femelle
Tipo di connettore - Num pin - Maschio o Femmina
Tipo de conector - Num pines - macho o hembra



Faisceau p. 268
Cablaggio p. 268
Cableado p. 268

Feux de position - Luci di posizione - Pilotos de posición

SMD04

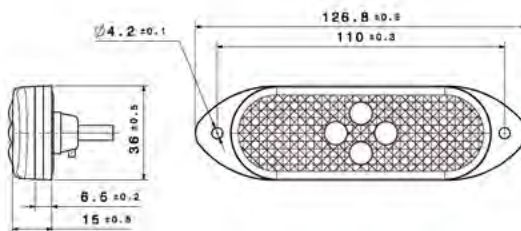

LED

24V

ADR



E₂ 05022



104130 500 mm **K**

104140 1500 mm **K**
CLICK-IN

104520 1000 mm **K**
adhésif - adesivo - adhesivo
CLICK-IN

104690 1000 mm **K**
SS-2P-M

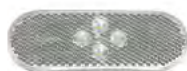

NEW **104840** 12V **K**

104720 24V **K**
SS-2P-M

FE04

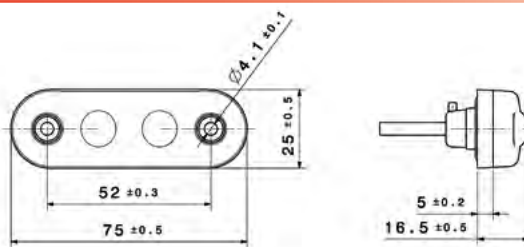

LED

24V

ADR



E₂ 05010
SAE P2

Affectations constructeurs
Applicazione primo impianto
Afectación primer equipo

ASCA p. 10
LAMBERET p. 44
RENAULT TRUCKS p. 63



104290 500 mm

104300 1500 mm

104310 5000 mm

D10132 200 mm

CLICK-IN



104570 300 mm

DT-2P-M



104450 300 mm

DT-2P-M



D14170

DT-2P-F

Feux de position - Luci di posizione - Pilotos de posición

SMD98



LED

12V
ou-o
24V

ADR



E₂ 04010

p. 166

p. 171

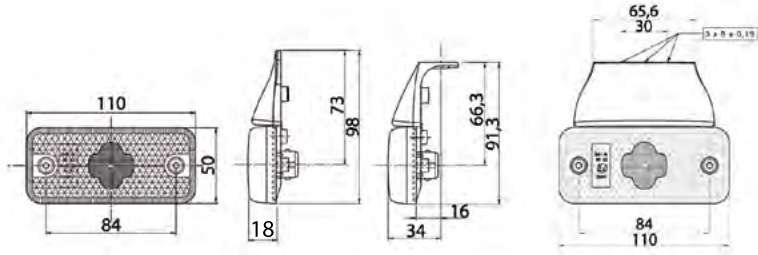

	198690	12V			D10500	24V 500 mm			D11399	24V 1500 mm			D13710	24V 1000 mm	
	198660	24V													

	D13876			001696		001716
--	---------------	--	--	---------------	--	---------------

FE94



T4W

12/24V

ADR



E₂ 4089

p. 161

p. 171

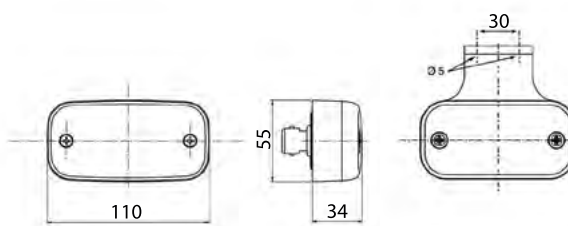

	194130			PE		194150	
--	---------------	--	--	-----------	--	---------------	--

	094036	
--	---------------	--

Feux de position - Luci di posizione - Pilotos de posición

FE02

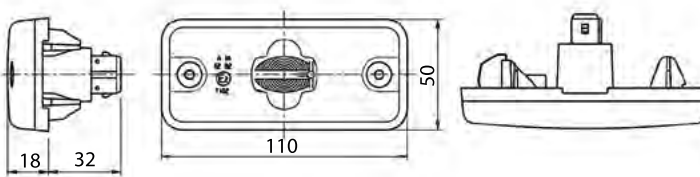

W5W



12/24V

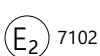

7102



102200



clippé - fissaggio con clip - fijación con clip

D13876

JPT-2P-F

001726

FPL93

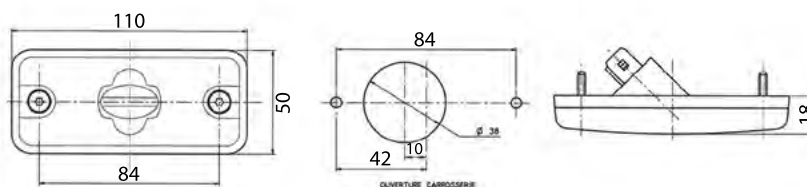

W5W



12/24V

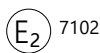

7102



193200



vissé - avvitato - atornillado

D13876

JPT-2P-F

001726



p. 168

FE95



140 mm x 65 mm x 30,5 mm



W5W



12/24V

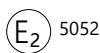

5052



195010

semelle plate - base piatta - base plana



195030

semelle galbée - base sagomata - base curvada

Affectations constructeurs
Applicazione primo impianto
Afectación primer equipo

DAF p. 20
RENAULT TRUCKS p. 63
VOLVO TRUCKS p. 101



FE87

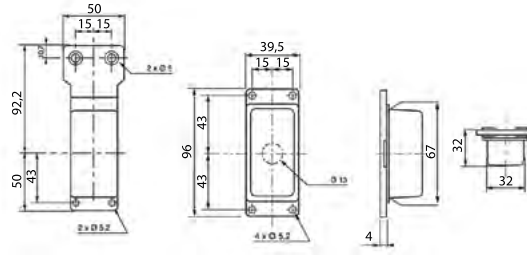
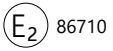

187120



187720



087020

cabochon - lente - tulipa

Feux de position - Luci di posizione - Pilotos de posición

FG80



R5W



12/24V



781
91715

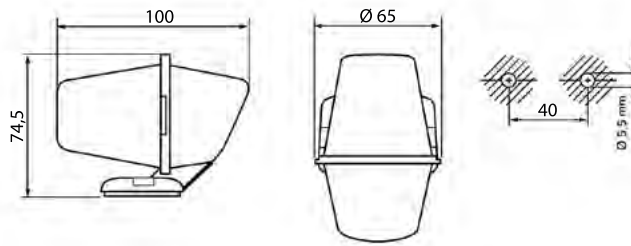

180010



080026



180040

R5W



080046

Feux de position - Luci di posizione - Pilotos de posición

SMD04



LED

24V

ADR



E₂ 05021

p. 160

p. 170

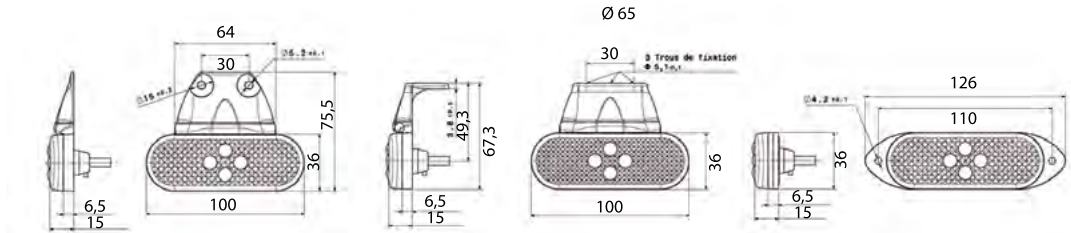

104090 500 mm **K**
104100 1500 mm **K**

CLICK-IN

104210 500 mm **K**
104220 1500 mm **K**

CLICK-IN

104250 500 mm **K**
104260 1500 mm **K**

CLICK-IN



104640 300 mm **K**
104650 1000 mm **K**

bride rallongée - supporto esteso - soporte extendido

CLICK-IN



D12699 1000 mm **K**

CLICK-IN



NEW **104760** LED-12V **K**
104670 LED-24V **K**

SS-2P-M



104770 LED-12V **K** **NEW**
104700 LED-24V **K**

SS-2P-M



D13880 SS-2P-F

SMCU



FEUX DE POSITION LATÉRAUX LED CLIGNOTANTS gestion selon supplément 6 - R48
 LUCI LATERALI LED LAMPEGGIANTI gestione secondo supplemento 6 - R48
 PILOTOS DE POSICION LED INTERMITENTES según suplemento 6 - R48



12/24V **D14722**

LED Side marker control unit

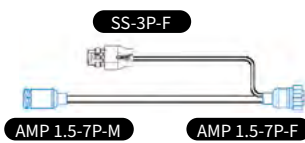

D14879



D14362

SS-3P-F



D13880

SS-2P-F

Feux de position - Luci di posizione - Pilotos de posición

SMD98

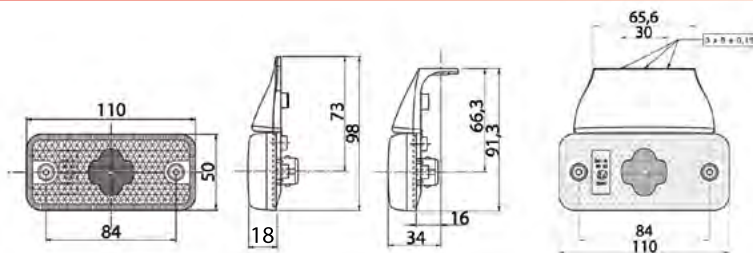

LED

12V
ou-o
24V



4xLED

2xLED

E₂ 8040

p. 161

p. 166

Affectations constructeurs
Applicazione primo impianto
Afectación primer equipo

FELDBINDER p. 27

IVECO p. 34

LAMBERET p. 44

LECINENA p. 49

MERCEDES p. 55

RENAULT TRUCKS p. 63

VOLVO p. 101



198510 4 x LED-12V K



198650 2 x LED-24V K



198810 4 x LED-12V K

198520 4 x LED-24V K

JPT-2P-M

JPT-2P-M

SS-2P-M



198580 4 x LED-12V K



198530 2 x LED-24V K



D13713 1000 mm K

198540 2 x LED-24V K

JPT-2P-M

JPT-2P-M

POS-2P-F



D10493 4 x LED-24V K



D10494 500 mm K



D10495 500 mm K

D10496 1500 mm K

CLICK-IN

CLICK-IN

CLICK-IN



D12867 2 x LED-24V K

CLICK-IN



D13876 JPT-2P-F



D13880 SS-2P-F



001696



001716

Feux de position - Luci di posizione - Pilotos de posición

SMD00



LED

24V

ADR



E₂ 1295

Affectations constructeurs
Applicazione primo impianto
Afectación primer equipo

RENAULT TRUCKS p. 63
VOLVO TRUCKS p. 101

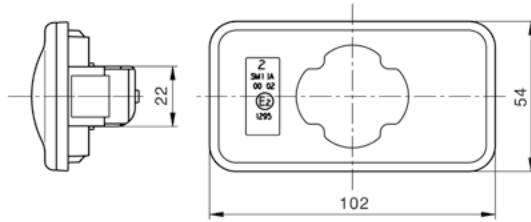

198620

K

Cuve blanche - cabochon PMMA
Scatola bianca - lente PMMA
Caja blanca - tulipa PMMA



198740

K

Cuve ambre - cabochon PC résistant haute température et chocs
Scatola arancione - lente PC resistenti alle alte temperature e agli urti
Caja naranja - tulipa de PC resistente a altas temperaturas y golpes



001766 600 mm

adaptateur - adattatore - adaptador

FE94



T4W

12/24V

ADR



E₂ 4093

p. 161

p. 171

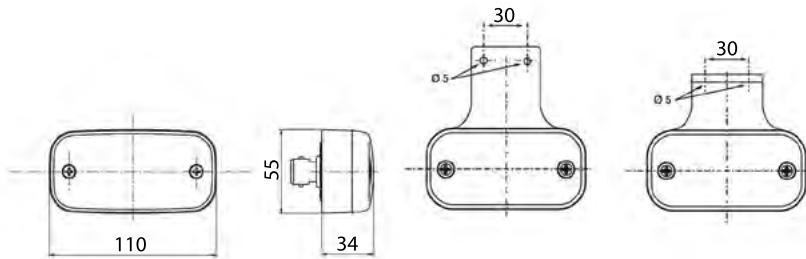

194010

K



PE



194020

K



194030

K



094016

K

Feux de position - Luci di posizione - Pilotos de posición

FPL93

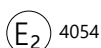
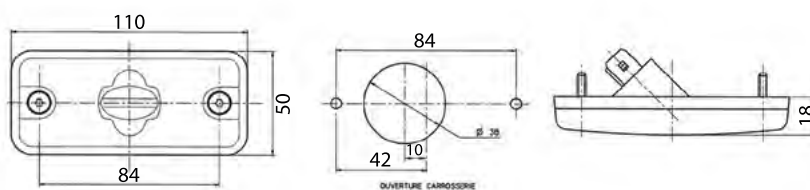

Affectations constructeurs
Applicazione primo impianto
Afectación primer equipo

DAF p. 20
FIAT p. 29
IVECO p. 34
RENAULT TRUCKS p. 63
VOLVO TRUCKS p. 101



193020



JPT-2P-M



193280



JPT-2P-M



193170



SS-2P-M



193360



SS-2P-M



193290

380 mm



SS-2P-M



D13876

JPT-2P-F



D13880

SS-2P-F



001726

JPT-2P-M



001916

SS-2P-M



001696



001716



FE87

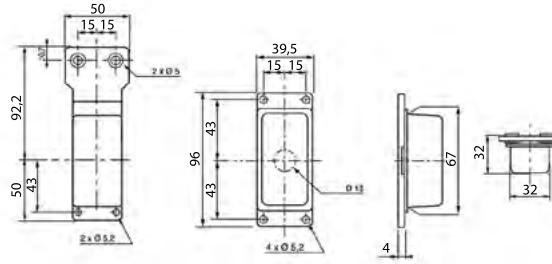
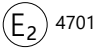

187140



187760



087040

cabochon - lente - tulipa

Feux de position - Luci di posizione - Pilotos de posición

FE04



LED

24V

ADR



E2 05011

p. 160

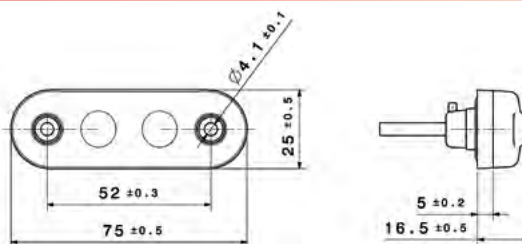

104330	500 mm
104340	1500 mm
104360	5000 mm



D10132 200 mm
CLICK-IN

SMD04



LED

24V

ADR



E2 05023

p. 160

p. 165

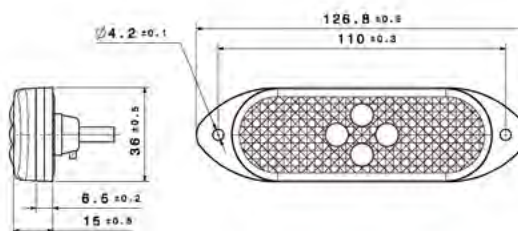

104170	500 mm	K		
104180	1500 mm	K	104680	K
			SS-2P-M	104710
			CLICK-IN	SS-2P-M



D13880 **SS-2P-F**

SMD98



LED

24V

ADR

H

E₂ 2065

p. 161

p. 166

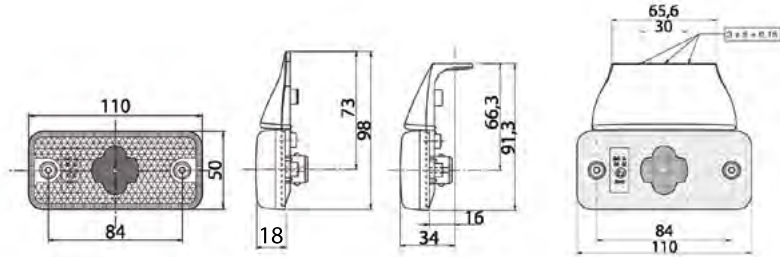

198640

K

JPT-2P-M

D11400 1500 mm

K

D10499 3500 mm

K

CLICK-IN



D13876

JPT-2P-F

001696

001716

FE94



T4W

12/24V

ADR

H V

E₂ 4091

p. 161

p. 167

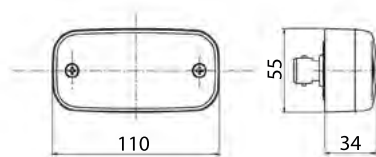

PE

194250

K



094056

K

Feux de position - Luci di posizione - Pilotos de posición

W97

83,8 mm x 24,2 mm x 10,4 mm



E₂₀ 1398
1397
1390
10R 2819

NEW



D16069
(66L708)

NEW



D16070
(66L709)

NEW



D16071
(66L710)

NEW



D16072
(66L710B)

NEW



D16073
(66L710G)

FE87



E₂ 86711

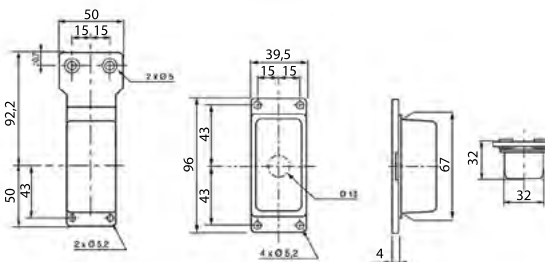

187130



187730



087030

cabochon - lente - tulipa

FE95



140 mm x 65 mm x 30,5 mm



E₂ 5126



195060

Feux de gabarits Luci d'ingombro Luces de anchura



Tricolore - Tricolore - Tricolor p. 174-176



Bicolore - Bicolore - Bicolor p. 177-178



SS-2P-F

Type connecteur - Nb pins - Mâle ou Femelle
Tipo di connettore - Num pin - Maschio o Femmina
Tipo de conector - Num pines - macho o hembra



Flashez le QR code pour plus d'infos
Scansiona il codice QR per maggiori informazioni
Escanee el código QR para obtener más info



Pièces détachées
Ricambi
Repuestos



Numéro d'homologation
Numero di omologazione
Número de aprobación

Feux de gabarits - Luci d'ingombro - Luces de anchura

FA3 LED



LED

12/24V

ADR

E₂ 14010

* fils nus - estremità cavo nuda - cable pelado

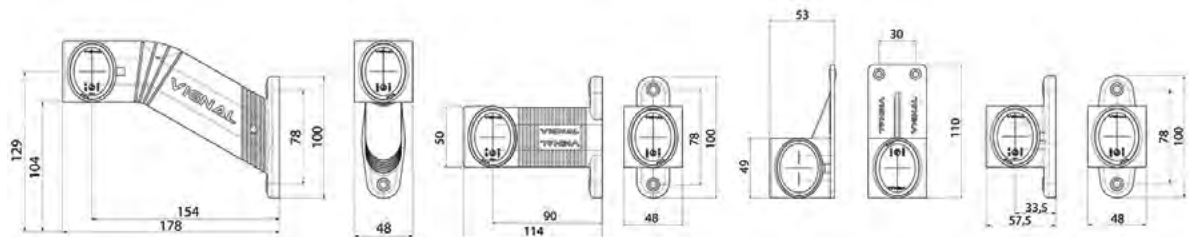

D14421* 1700 mm

D14427 1500 mm

gauche - sinistra - izquierda

CLICK-IN



D14422* 1700 mm

D14428 1500 mm

droit - destra - derecha

CLICK-IN



D14423 1500 mm

gauche - sinistra - izquierda

POS-2P-F

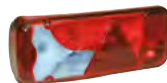

Pour / Per / Para LC8
D14423 - D14424 - D13875



D14424 1500 mm

droit - destra - derecha

POS-2P-F



D14425 1500 mm

gauche - sinistra - izquierda

SS-2P-F



Pour / Per / Para LC12T
D14425 - D14426 - D14655



D14426 1500 mm

droit - destra - derecha

SS-2P-F



D14431* 1700 mm

D14429 1500 mm

gauche - sinistra - izquierda

CLICK-IN



D14432* 1700 mm

D14430 1500 mm

droit - destra - derecha

CLICK-IN



D14031* 1700 mm

D14035 1500 mm

D14655 1500 mm

symétrique - simmetrico - simétrico

CLICK-IN

SS-2P-F



D14030* 1700 mm

D14034 1500 mm

D13875 1500 mm

symétrique - simmetrico - simétrico

CLICK-IN

POS-2P-F

FA3 LC12 LED



LED

12/24V

ADR

E₂ 14010



D14781 350 mm
gauche - sinistra - izquierda **SS-2P-F**



D14782 350 mm
droit - destra - derecha **SS-2P-F**

FA3 LED LC8



LED

12/24V

ADR

E₂ 14010



D14038 500 mm
gauche - sinistra - izquierda **CLICK-IN**



D14037 500 mm
droit - destra - derecha **CLICK-IN**



D14039 350 mm
gauche - sinistra - izquierda **POS-2P-F**



D14040 350 mm
droit - destra - derecha **POS-2P-F**

Feux de gabarits - Luci d'ingombro - Luces de anchura

DX LC8



W5W



24V

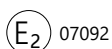

07092



D13034 500 mm

gauche - sinistra - izquierda **CLICK-IN**



D13035 500 mm

droit - destra - derecha **CLICK-IN**



D12712 350 mm

gauche - sinistra - izquierda **POS-2P-F**



D12711 350 mm

droit - destra - derecha **POS-2P-F**

DX



W5W



24V

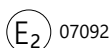

07092



D12430



D12429

1500 mm

CLICK-IN



D12428

1400 mm

CLICK-IN

DX LED



12/24V

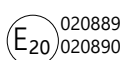

020889
020890



90 mm x 50 mm x 180 mm



D13624

fils nus - estremità cavo nuda - cable pelado

Feux de gabarits - Luci d'ingombro - Luces de anchura

DX



W5W

12/24V

ADR

E₂ 10035



* fils nus - extremità cavo nuda - cable pelado

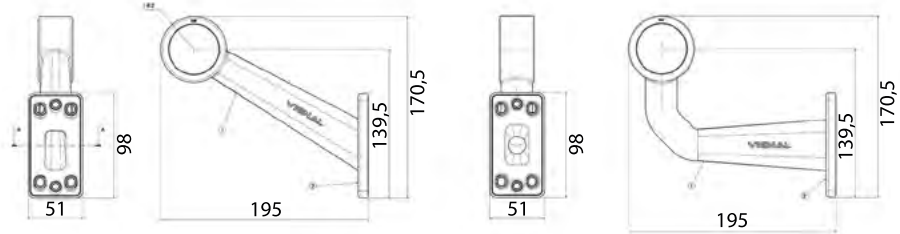

D10642 *



D10643 *



D10503

600 mm

CLICK-IN



D10800

R5W - 12/24V



D11899

500 mm

2 voies - 2 vie - 2 vías
Pour / Per / Para LC8

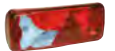

POS-2P-F



611010



611020



D13277 350 mm



D11147 500 mm



610080 R5W

Lampe non fournie - senza lampadina - lampará no incluida

FE12



LED

12/24V

E₂₄ 020078



* fils nus - extremità cavo nuda - cable pelado

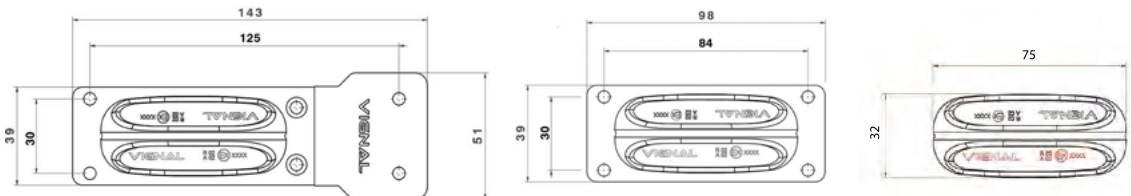

112110 * 1000 mm



112710 * 1000 mm



112120 * 1000 mm

112130 1500 mm **CLICK-IN**

112720 1500 mm **CLICK-IN**

Feux de gabarits - Luci d'ingombro - Luces de anchura

FE88

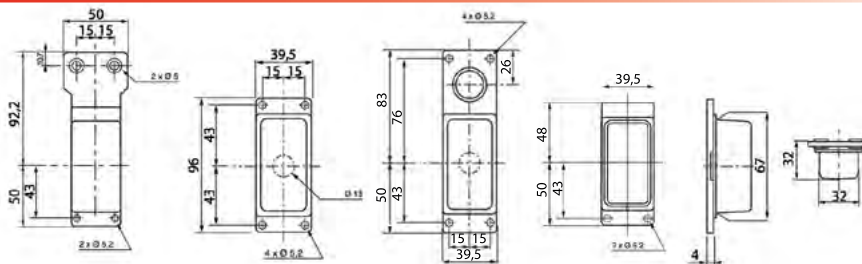
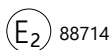

188110



188210



188010

pour presse-étoupe 000176
per guarnizione pressacavo 000176
para prensa estopa 000176



188710



188610

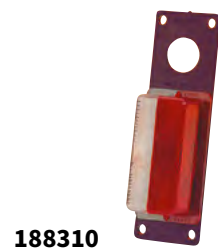

188310



088010

cabochon - lente - tulipa



000176

FE81



107 mm x 47 mm x 41 mm



181000



000086

Signalisation passive

Segnaletica passiva

Señalización



Bandes réfléchissantes - Nastri riflettenti - Cintas reflectantes
p. 180-181



Plaques réfléchissantes - Targhe riflettenti - Placas reflectantes
p. 182-183



Catadioptres - Catadiottri - Catadióptricos
p. 184

Triangle de présignalisation - Triangolo di segnalazione - Triángulo de emergencia
p. 184



Flashez le QR code pour plus d'infos
Scansiona il codice QR per maggiori informazioni
Escanee el código QR para obtener más info



Pièces détachées
Ricambi
Repuestos



Numéro d'homologation
Numero di omologazione
Número de aprobación

Bandes réfléchissantes - Nastri riflettenti - Cintas reflectantes

R104



50 m x 50,8 mm

Surface rigide - Struttura rigida - Estructura rígida

E₁₃ 104R-0001



D12713



D12715



D12714

E₁₃ 104R-0002



D13206



D13205



D13207

Carrés pré-espacés - pezzi pre-tagliati - cuadrados espaciados

50 m x 50,8 mm

NEW

Surface rigide - Struttura rigida - Estructura rígida

E₁ 104R



D16087



D16086



D16088

NEW

E₁ 104R-003244

Surface souple - Superfici telonate - Estructura flexible



D16104



D16103



D16105

Carrés pré-espacés - pezzi pre-tagliati - cuadrados espaciados

BA



2 x 9 m x 141 mm



D14714 Cl. A: >80m

D14716 Cl. B: >500m

Classe 1 : ville et route nationale - Strade urbane - Ciudad y carreteras nacionales
Classe 2 : autoroutes et voies rapides - Strade extraurbane - autovías

2 x 45 m x 141 mm



D14715 Cl. A: >80m

REFLECTIVE KIT



Homologué - Durable - Visible minimum à 80m - Facile à poser
Omologato - Resistente - Visibile da almeno 80 m - Facile da installare
Homologado - Duradero - Visible a 80 m como mínimo - Fácil de instalar

Ref sur demande
P/N su richiesta - Ref. a petición

NEW

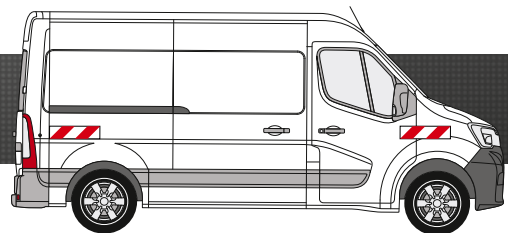
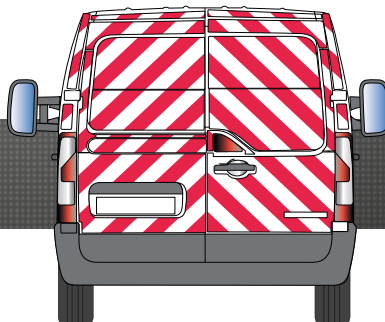
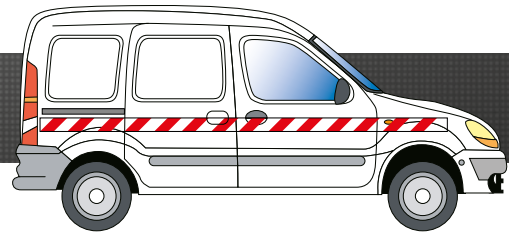
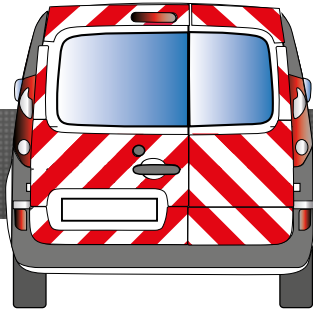

Plaques réfléchissantes - Targhe riflettenti - Placas reflectantes

R70



Camions / Cars et bus - Camion / Autobus - Camiones / Autobuses

E₄ 017016

* adhésif - autoadesivo - adhesivo

1 x (130 x 1130)



D14710 Alu 1 mm

2 x (130 x 565)



D14706 Adhésif *
D14707 Alu 1 mm
D14535 Plastique

4 x (130 x 282)

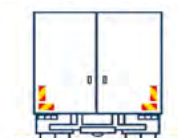

D14711 Alu 1 mm

Remorques - Rimorchio - Remolques

1 x (195 x 1130)



D14712 Alu 1 mm

2 x (195 x 565)



D14708 Adhésif *
D14709 Alu 1 mm
D14536 Plastique

4 x (195 x 283)



D14713 Alu 1 mm

DSR



250 mm x 170 mm



D14990
Camions et poids lourds

250 mm x 170 mm



D14991
Cars et bus

CONVOI



423 x 423 x 1 mm

NEW



D16031

(76RE50) Cl. A: 👁️ ->80m

Classe 1 : ville et route nationale - Strade urbane - Ciudad y carreteras nacionales
Classe 2 : autoroutes et voies rapides - Strade extraurbane - autovías

282 x 282 x 1 mm

NEW



D16032

(76RE56) Cl. B: 👁️ ->250m

1200 x 400 mm

NEW



D16026

(80CONVOIEX03) Cl. B: 👁️ ->250m

1900 x 250 mm



NEW

CONVOI EXCEPTIONNEL

D16027

(80CONVOIEX04) Cl. B: 👁️ 250m

PICTOGRAM



E₂ 10R-03

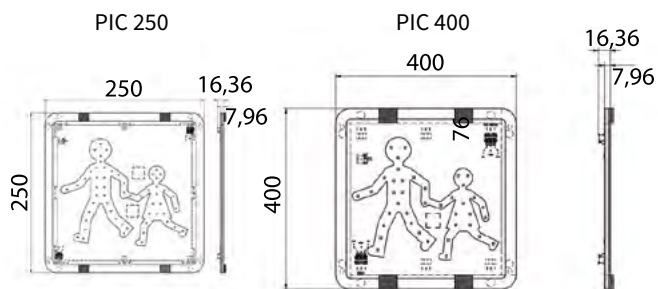

NEW



1x PIC 250 + 1x PIC 400 + cache/cover



D16008

(PIC250/400.C.SC/C)

NEW



1x PIC 250 + 1x PIC 400



D16009

(PIC250/400.C.ES.SC/C)

Catadioptrés - Catadiottri - Catadióptricos

CA



Ø 61 mm



- D14592 ●
- D14591 ○
- D14593 ●

adhésif - autoadesivo - adhesivo

Ø 85 mm

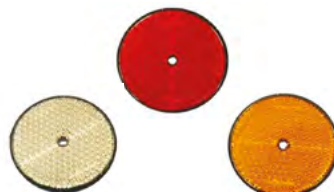

- D14589 ●
- D14588 ○
- D14590 ●

adhésif - autoadesivo - adhesivo

57 mm x 39 mm



- D14595 ●
- D14594 ○
- D14596 ●

adhésif - autoadesivo - adhesivo

105 mm x 45 mm



- 240366 ●
- 240346 ○
- 240356 ●

adhésif - autoadesivo - adhesivo

105 mm x 45 mm - M4



- 241366 ●
- 241346 ○
- 241356 ●

adhésif - autoadesivo - adhesivo

105 mm x 54 mm



- D14530 ●
- D14529 ○
- D14531 ●

adhésif - autoadesivo - adhesivo

159 mm x 159 mm x 159 mm



D14587

TRIANGLE



Affectations constructeurs
Applicazione primo impianto
Afectación primer equipo

RENAULT TRUCKS p. 63
SCANIA p. 91
VOLVO p. 101



D10596
(564.VTO.VLG)

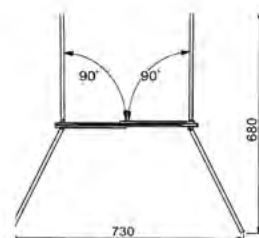
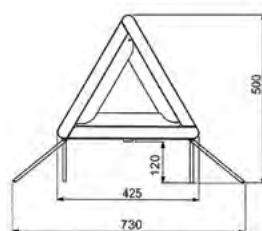

Phares de travail

Fari da lavoro

Faros de trabajo



Phares de recul - Fari retromarcia - Faros marcha atrás

p. 186



LED

p. 187-200



DT-2P-M

Type connecteur - Nb pins - Mâle ou Femelle
 Tipo di connettore - Num pin - Maschio o Femmina
 Tipo de conector - Num pines - macho o hembra



Vitre en verre trempé
 Lente in vetro temperato
 Tulipa de vidrio templado



Flashez le QR code pour plus d'infos
 Scansiona il codice QR per maggiori informazioni
 Escanee el código QR para obtener más info



Vitre en polycarbonate
 Lente in policarbonato
 Tulipa de policarbonato



Pièces détachées
 Ricambi
 Repuestos



Faisceau p. 262
 Cablaggio p. 262
 Cableado p. 262

Phares de recul - Fari retromarcia - Faros marcha atrás

SL 1000 R23



DT-2P-M

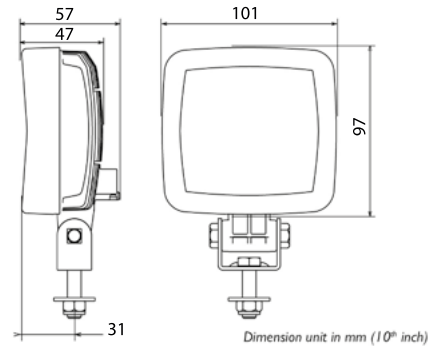

LED

12/24V
14W

1000 Lumen

ADR

✓ R23 ✓ R10

E₂ 19140

IP69K

D14857
(A0787A711300)



DT-2P-M

D14880
(A0787A712400)

Aluminium



2963 R23

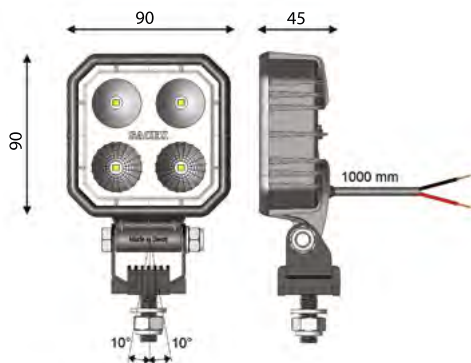

LED

10/30V
9W

1000 Lumen

✓ R23 ✓ R10

E₁₁ 7573

IP69K

D14555
(29.63.L23.C0V) 1000 mm

D14556 *
(29.63.L2I.CDV)



* Interrupteur - interruttore - interruptor

SV 1000



NEW

LED

12/24V
20W

1000 Lumen

IP69K

*Interrupteur - interruttore - interruptor

Nouveau! Meilleure solution 1000 Lumen en remplacement un phare halogène
Phare de travail professionnel, boîtier plastique robuste et fiabilité des performances.
Novità! La migliore soluzione da 1000 Lumen per sostituire un faro da lavoro alogeno
Faro da lavoro professionale, robusto involucro in plastica e prestazioni affidabili.
¡Nuevo! La mejor solución de 1000 lúmenes para sustituir a un faro halógeno
Luz de trabajo profesional, robusta carcasa de plástico y rendimiento fiable.

NEW

PC



DT-2P-M



D16111
(A0767A769600)

D16155
(A0767A769700)

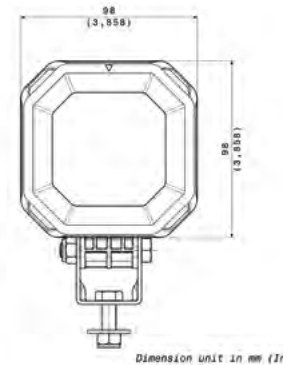

Dimension unit in mm (in)

NEW

PC



FIL-CABLE

D16156
(A0767A769800)

D16157
(A0767A769900)



FLOOD

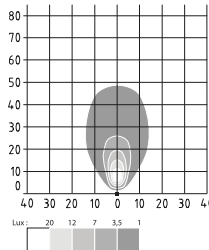

Phares de travail - Fari da lavoro - Faros de trabajo

 **OE Original Parts**

Eclairage flood homogène de proximité

*Illuminazione omogenea Flood
Iluminación homogénea Flood*

1000, 1500 ou 2000 Lumen effectifs

*1000, 1500 o 2000 lumen effettivi
1000, 1500 o 2000 lúmenes efectivos*

Rond, Carré, Rectangle ou Ovale

*Rotondo, quadrato, rettangolare o ovale
Redonda, cuadrada, rectangular u ovalada*

Compatibilité Électro-Magnétique classe 5

*Compatibilità elettromagnetica classe 5
Clase de compatibilidad electromagnética 5*

Protection Load dump

*Load dump protetto
Load dump protegido*



SL 1000



LED

 12/24V
14W

 1000 Lumen

 **IP69K**

PC



D14850
(A0787A710700)



DT-2P-M

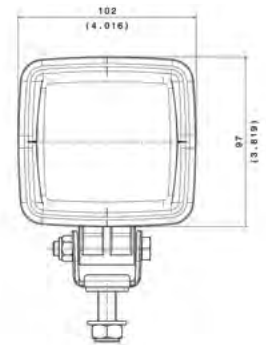
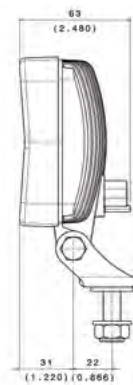
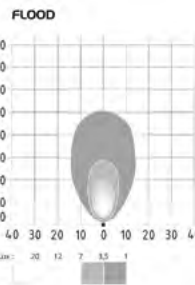

SL 1500



LED

 12/24V
20W

 1500 Lumen

 **IP69K**

PC



D14851
(A0787A710800)



DT-2P-M

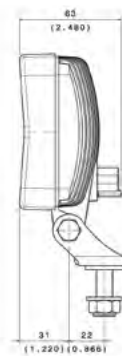
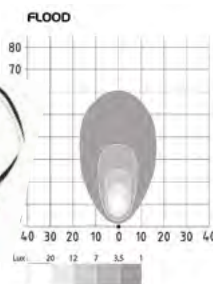

SLA 2000



LED

12/24V
29W

2000 Lumen

IP69K



DT-2P-M

D14852
(A0787A710900)

Aluminium [SCANIA p. 92](#)

NEW



LEAR-2P-M

D16110
(A0787A7548C3)

Aluminium [MAN p. 53](#)

PC



DT-2P-M

D14856
(A0787A711700)

Aluminium

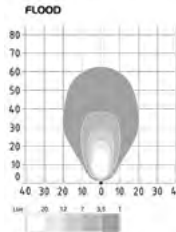
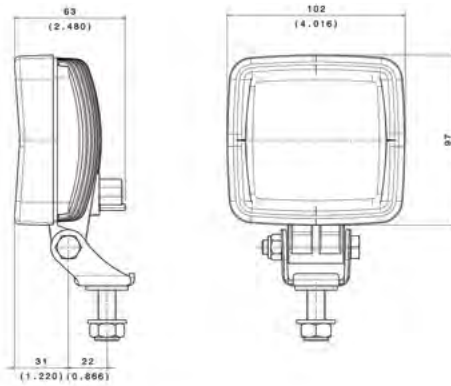

RLA 2000



LED

12/24V
29W

2000 Lumen

IP69K



DT-2P-M

D14855
(A0187A711200)

Aluminium

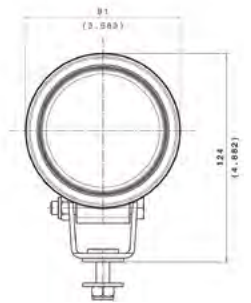
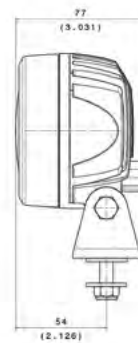
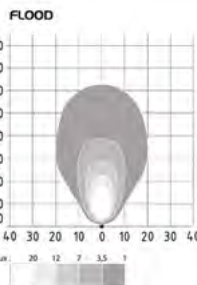

Phares de travail - Fari da lavoro - Faros de trabajo

NO GLARE



N'éblouit ou n'aveugle pas - Éclaire la zone de travail
 Non acceca o abbaglia - illumina l'area di lavoro
 Sin cegamiento ni deslumbramiento: ilumina el área de trabajo

LED

12/24V
29W

2000 Lumen

IP69K



DT-2P-M



D14968
(A0787A7284C3)

Aluminium

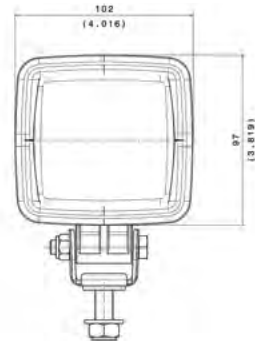
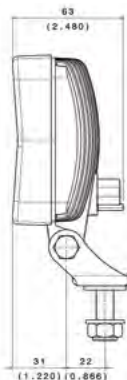

NEW



DT-2P-M



D15077
(A0187A7603C3)

Aluminium

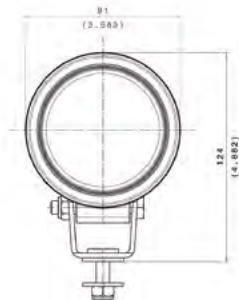
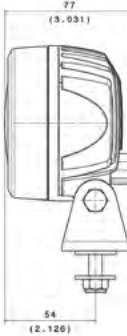

QLA 1000



NEW



DT-2P-M

LED

12/24V
14W

1000 Lumen

IP69K



D16119
(A0427A755400)

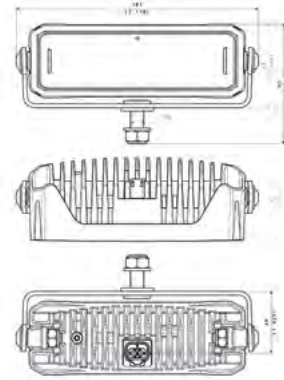
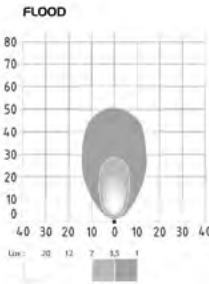

QLA 2000



NEW



DT-2P-M

LED

12/24V
29W

2000 Lumen

IP69K



D16120
(A0427A755600)

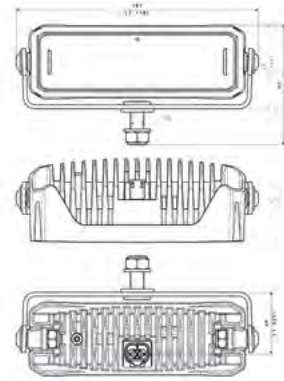
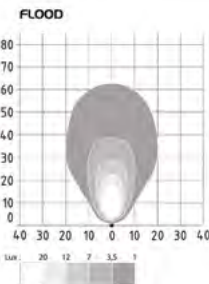

QLA GLOWING



NEW



DT-2P-M

LED

12/24V
29W

IP69K



D16114
(A0427A773600)

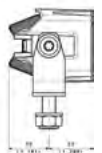
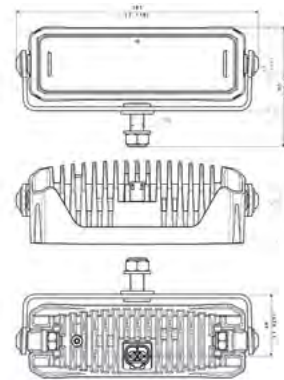
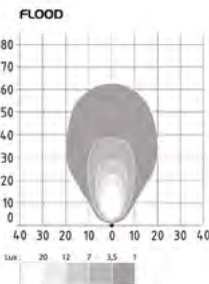

Phares de travail - Fari da lavoro - Faros de trabajo

OLA 1000



DT-2P-M

LED

12/24V
14W

1000 Lumen

IP69K

D14965
(A0487A7402C3)

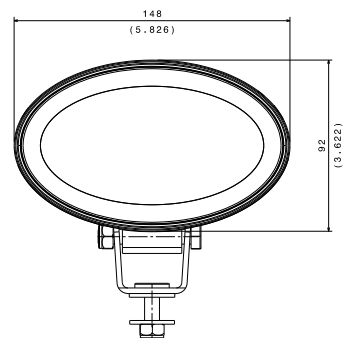
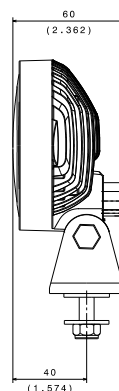
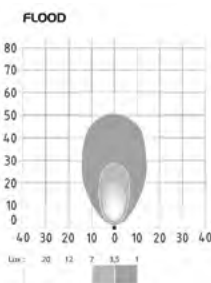

NEW



DT-2P-M

D15093
(A0487A7479C3)

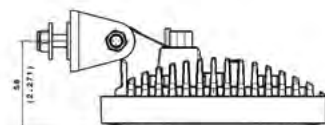
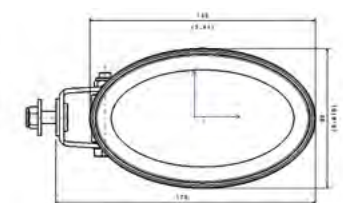
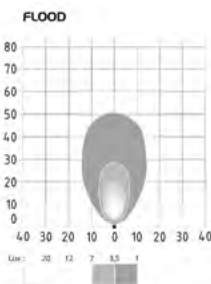

OLA 1500



DT-2P-M

LED

12/24V
20W

1500 Lumen

IP69K

D14966
(A0487A7406C3)

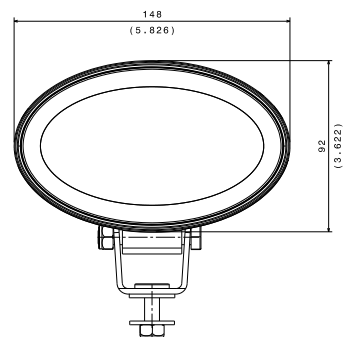
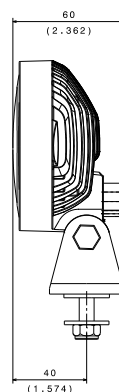
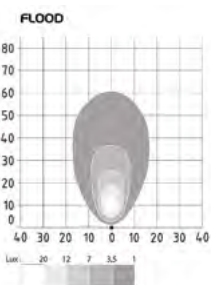

OLA 1500



NEW



LED

12/24V
14W

1000 Lumen

IP69K



DT-2P-M

D15094
(A0487A7481C3)

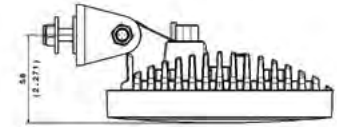
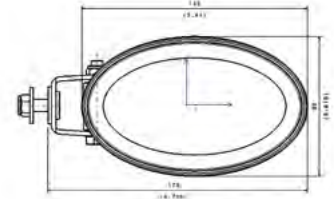
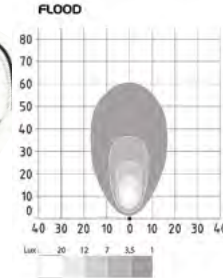

OLA 2000



LED

12/24V
29W

2000 Lumen

IP69K



DT-2P-M

D14967
(A0487A7499C3)

Aluminium

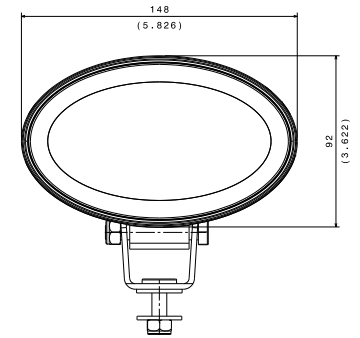
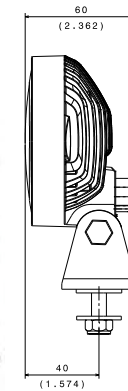
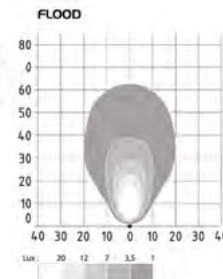

NEW



DT-2P-M



D15095
(A0487A7483C3)

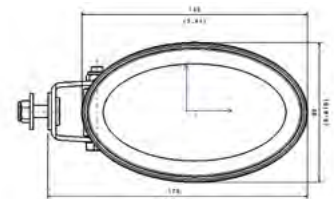
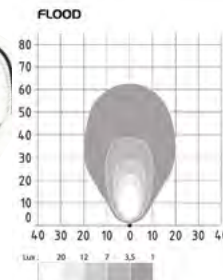

SHD 3000



NEW



LED

12/24V
36 W

3000 Lumen

IP69K



DT-2P-M

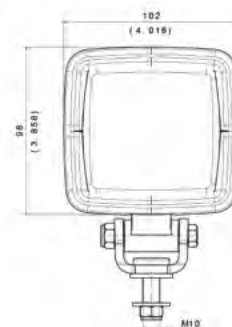
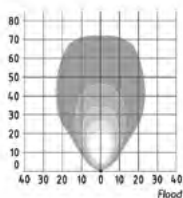

D15100
(A0787A7739C3)

Aluminium

SHD 5000



NEW



LED

12/24-100V
57 W

5000 Lumen

IP69K



DT-2P-M

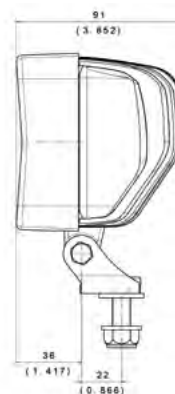
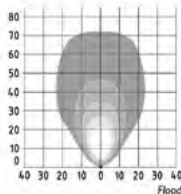

D16124
(A0787A7737C3)

Aluminium

BL15



LED

24V



E2 16007
10R-0516079

Affectations constructeurs
Applicazione primo impianto
Afectación primer equipo

CHEREAU p. 17
FRUEHAUF p. 31
LECAPITAINE p. 48
TROUILLET p. 97

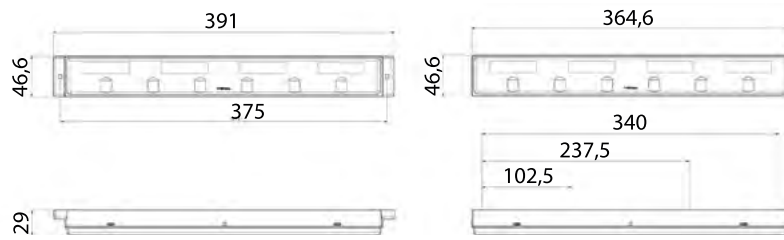

165020

gauche - sinistra - izquierda



DT04-4P-M



DTM06-4S-4P-F



165030

droit - destra - derecha



165040

gauche - sinistra - izquierda

Fixation par l'avant
Fissaggio frontale
Fijación frontal



165050

droit - destra - derecha



D14436

DT06-4S-4P-F



D14435

DTM04-4P-M

Indicateur de direction à défilement - feux de détresse flash
Indicatore di direzione dinamico - luci di emergenza flash
Intermitentes dinámicos - luces de emergencia flash

Feu de travail 1200 Lumen
Faro da lavoro 1200 Lumen
Faro de trabajo 1200 Lumen



Phares de travail - Fari da lavoro - Faros de trabajo

2960

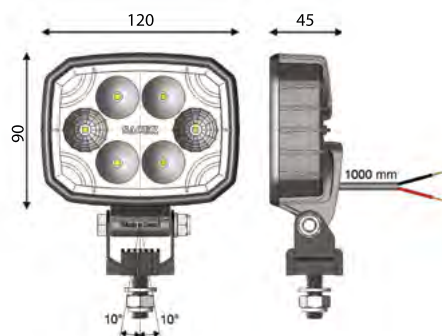

LED

10/30V
12 W

1500 Lumen

R10

IP69K

D14540
(29.60.L00.C0V) 1000 mm

2961

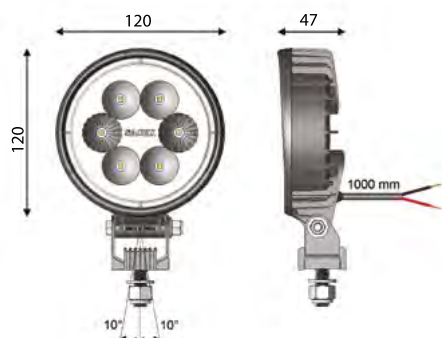

LED

10/30V
12 W

1500 Lumen

R10

IP69K

D14542
(29.61.L00.C0V) 1000 mm

2962

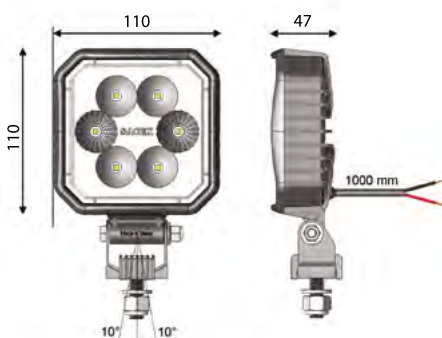

LED

10/30V
12 W

1500 Lumen

R10

IP69K

D14544
(29.62.L00.C0V) 1000 mm

2963



LED

10/30V
9 W

1000 Lumen

R10

IP69K



D14547
(29.63.L00.COV) 1000 mm



D14552
(29.63.LA0.COV) 1000 mm

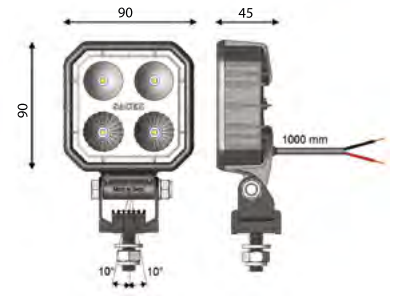

D14553
(29.63.L0A.COV) 1000 mm

2963



LED

10/30V
9 W

1000 Lumen

R10

IP69K



D14549 *
(29.63.LMI.COV) 1000 mm

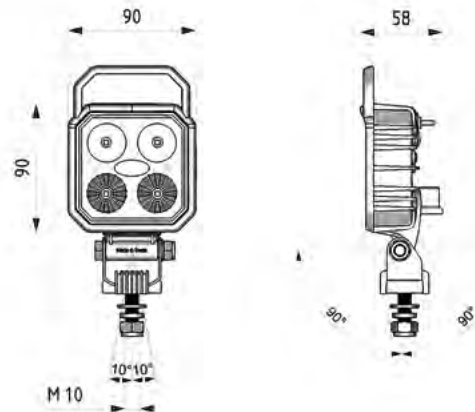

*Interrupteur - interruttore - interruptor

RC 850 LED



PC

LED

10/30V
12 W

1500 Lumen

R10

IP69K



D14743 1000 mm

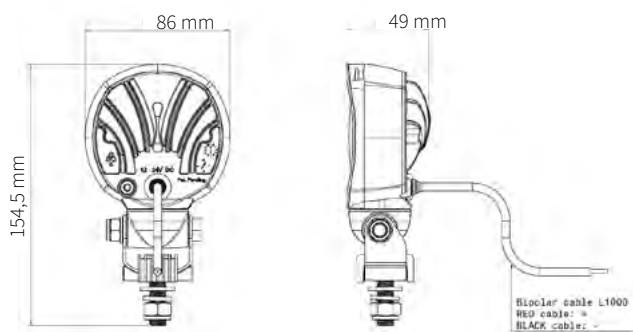

PC



D14744



DT-2P-M

PC



D14745
clippé - fissaggio con clip - fijación con clip

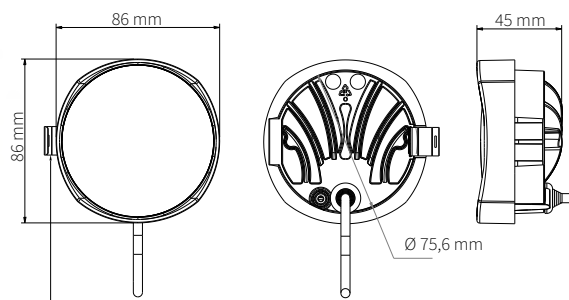

Compact (Ø 8,6 cm) et léger
Compatto (Ø 8,6 cm) e leggero
Compacto (Ø 8,6 cm) y ligero



FTC



LED

12/24V
15 W

850 Lumen

IP69



D14191

batterie rechargeable
batteria ricaricabile
batería recargable



High power 100%
Eco 30%
Flash SOS

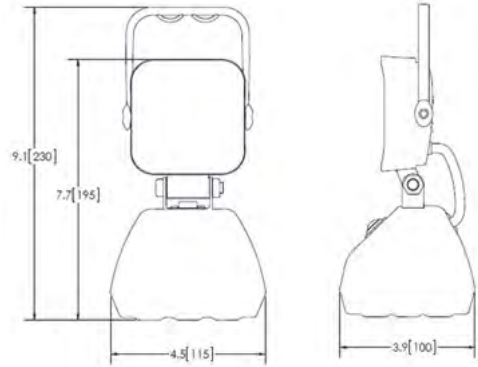

MINILIGHT



LED

12/24V

1000 Lumen

R10

IP67

NEW



D14994

(MINILIGHT.CR) 1000 mm

111 mm x 84 mm



NEW



D15048

(MINILIGHT.CRI) 1000 mm



Interrupteur - interruttore - interruptor

CAMLIGHT

LED

12/24V

1000 Lumen

R10

IP69K

NEW

Caméra
Telecamera
Cámara



D16042
(69 CAMLIGHT1)

DT-2P-M



2 en 1 : éclaire tout en filmant - réduit les angles morts - connexion moniteur via sortie vidéo 4 pins

2 in 1: illumina durante le riprese - riduce gli angoli morti - collegamento al monitor tramite uscita video a 4 pin

2 en 1: ilumina mientras filma - reduce los ángulos muertos - conexión de monitor con salida de vídeo de 4 vías



Éclairage de sécurité

Luci di segnalazione

Faros de advertancia



DT-2P-M

Type connecteur - Nb pins - Mâle ou Femelle
Tipo di connettore - Num pin - Maschio o Femmina
Tipo de conector - Num pines - macho o hembra



Vitre en verre trempé
Lente in vetro temperato
Tulipa de vidrio templado



Flashez le QR code pour plus d'infos
Scansiona il codice QR per maggiori informazioni
Escanee el código QR para obtener más info

Éclairage de sécurité - Luci di segnalazione - Faros de advertancia

SL BLUE



NEW

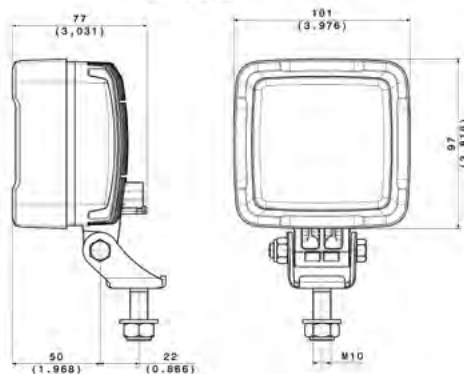

LED

12/36V
15W



IP69K

D16118
(A0787A763800)



DT-2P-M



SHD BLUE RED

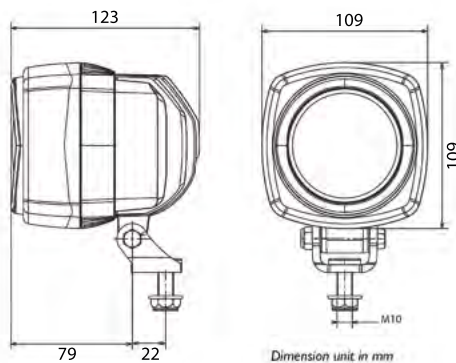

LED

12/24-100V
5W



IP69K

D14249
(A0787A625500)



DT-2P-M



WARNING LINE



COMPACT - COMPATTO - COMPACTO

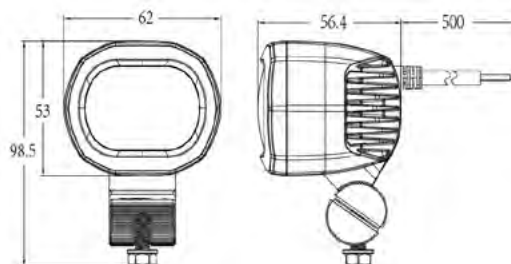

LED

12/24-80v
6W



IP67

D14357



D14358

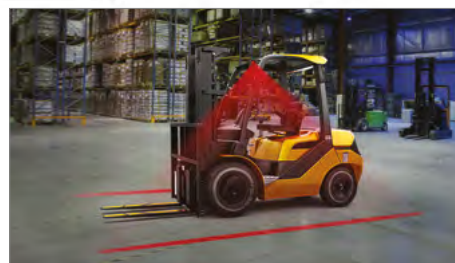

Éclairage de sécurité - Luci di segnalazione - Faros de advertancia

SAFETY STATIC



NEW



D16160

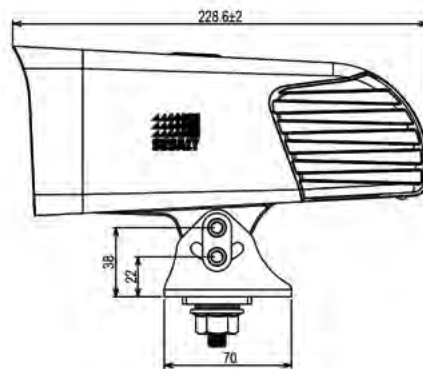
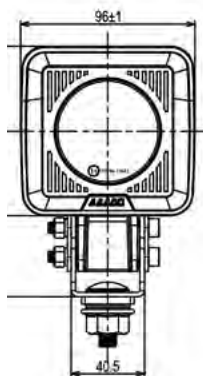

LED

10/30V
28W

E₉ 10R-06 23613

IP69K



SESA MOONLIGHT



NEW



D16022
(MOO.SIV.W)



LED

12/24V
15 W

IP69K

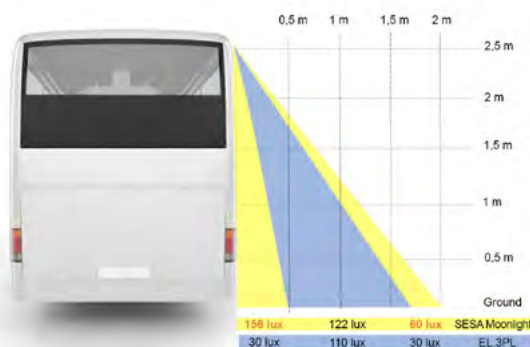

NEW



D16023
(MOO.SIV.R)



Phares de conduite

Proiettori

Faros delanteros



DT-2P-M

Type connecteur - Nb pins - Mâle ou Femelle
Tipo di connettore - Num pin - Maschio o Femmina
Tipo de conector - Num pines - macho o hembra



Flashez le QR code pour plus d'infos
Scansiona il codice QR per maggiori informazioni
Escanee el código QR para obtener más info



Pièces détachées
Ricambi
Repuestos

CHL 2 LED



LED



10/36V
50W High Beam
30W Low Beam



R112 - R6 - R7



IP69K



ISO PULSE
13207-1



Phare de conduite LED homologué

*Proiettore a LED omologato
Faro delantero LED homologado*

Performance lumineuse best in class

*Prestazioni di illuminazione più luminose e innovative
Rendimiento de iluminación más brillante e innovadora*

Compatibilité plug and play

*Compatibilità plug and play
Compatibilidad plug and play*

Design évite l'accumulation de neige et de glace

*Il design impedisce l'accumulo di neve e ghiaccio
Diseño evita la acumulación de nieve y hielo*

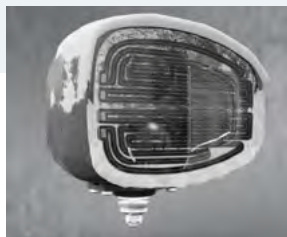

Nouveau! Technologie de dégivrage active et autonome
Nuovo! Tecnologia antighiaccio attiva e autonoma
¡Nuevo! Tecnología de deshielo activa y autónoma



D14964
(A0831A7332A4)

gauche - sinistra - izquierda



DT04-6P-M



D14963
(A0831A7333A4)

droit - destra - derecha

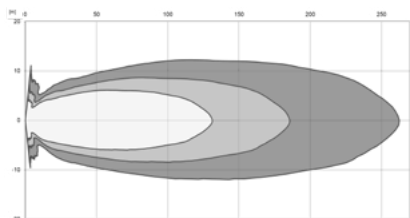

High beam light pattern

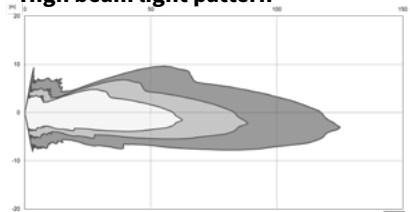

Low beam light pattern

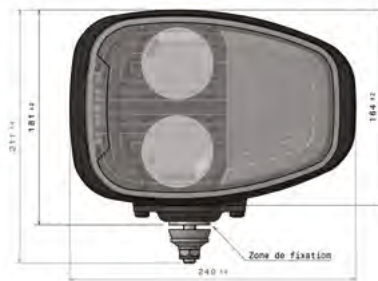
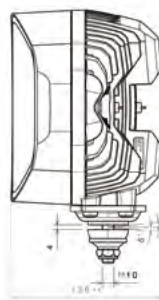

D14352
(A87005182400)

DT04-6P-F

Phares de conduite - Proiettori - Faros delanteros

CHL 1 LED



12/24V
50W High Beam
48W Low Beam



R112 - R6 - R7



IP69

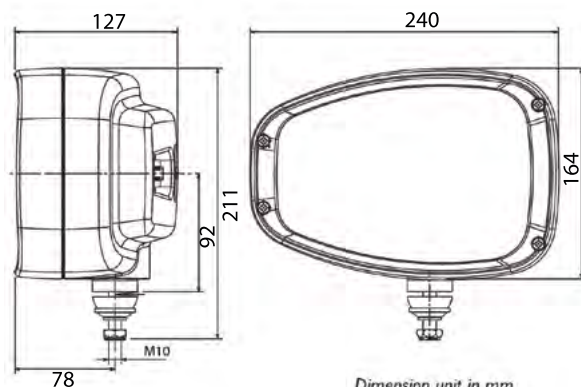

Feux de route - Feux de croisement - Indicateur de direction avant et latéral - Position
Abbagliante - Anabbagliante - Indicatore di direzione anteriore e laterale - Posizione
Luces de carretera - Luces de cruce - Intermitentes delanteros y laterales - Posición



D14324
(A0831A673200)

gauche - sinistra - izquierda

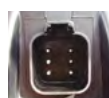

DT04-6P-M



D14325
(A0831A673300)

droit - destra - derecha



D14352
(A87005182400)

DT04-6P-F



Ref sur demande
P/N su richiesta - Ref. a petición

CHL1 H4

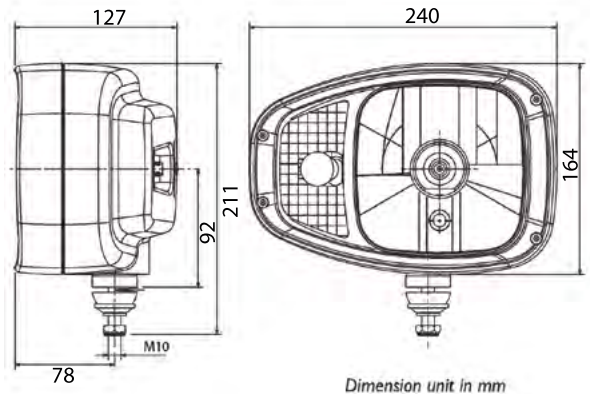
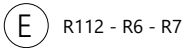

D14320
(A0830A673600) 12V

D14322
(A0830A673400) 24V

gauche - sinistra - izquierda



DT04-6P-M



D14321
(A0830A673700) 12V

D14323
(A0830A673500) 24V

droit - destra - derecha



D14352
(A87005182400)

DT04-6P-F

Phares de conduite - Proiettori - Faros delanteros

CL2 LED

LED

12/24V



5W Low Beam OFF Road

3W Turn light

2W Pilot light



IP69



R148 - R149

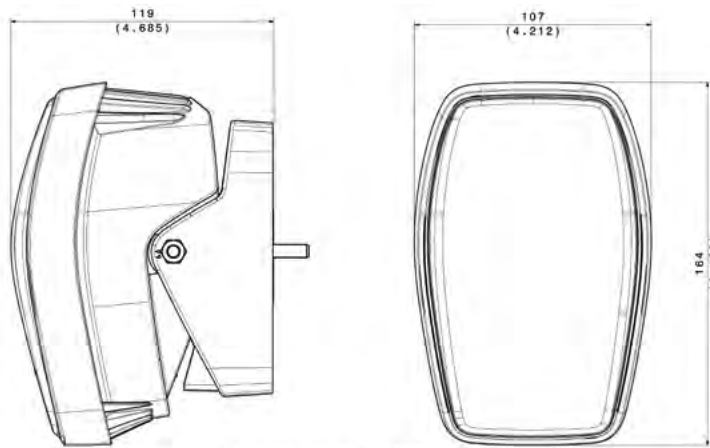

Dimension unit in mm (Inch)



Feux de croisement - Indicateur de direction - Position
Anabbagliante - Indicatore di direzione - Posizione
Luces de cruce - Intermitentes - Posición



NEW



D16115
(A0801A765600)

gauche - sinistra - izquierda



FEP-4P-M

NEW



D16115
(A0801A765600)

droit - destra - derecha

Feux auxiliaires

Fari ausiliari

Iluminación auxiliar



Flashez le QR code pour plus d'infos
Scansiona il codice QR per maggiori informazioni
Escanee el código QR para obtener más info

LED BARS SIGNAL



NEW

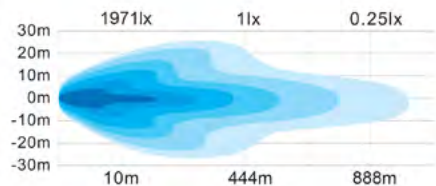
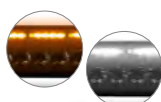

D16047 21,5"

Phare longue portée R112 - Flash ambre R65 - Position ambre et blanc
 Luce a lunga portata R112 - flash ambra R65 - posizione ambra e bianca
 Luz de largo alcance R112 - Destello ámbar R65 - Posición ámbar y blanco



12/24V



IP69K



R112

NEW

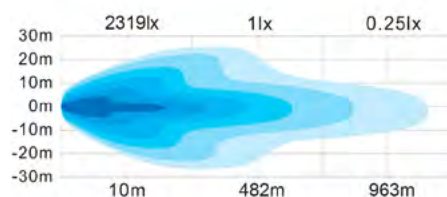

D16048 21,5"

Phare longue portée R112 - dégivrage automatique
 Luce a lunga portata R112 - sbrinamento automatico
 Luz de largo alcance R112 - deshielo automático



NEW

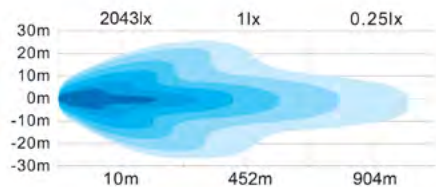

D16049 20"

Phare longue portée R112
 Luce a lunga portata R112
 Luz de largo alcance R112

NEW

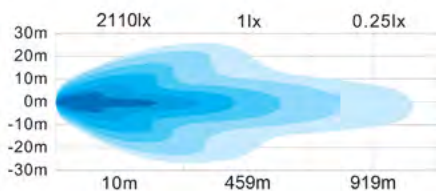

D16050 20"

Phare longue portée R112 - flash ambre R65
 Luce a lunga portata R112 - flash ambra R65
 Luz de largo alcance R112 - destello ámbar R65

LED BARS SIGNAL



NEW

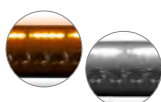

LED



12/24V



IP69K



R112



D16051 13"

Phare longue portée R112 - Flash ambre R65 - Position ambre et blanc
Luce a lunga portata R112 - flash ambra R65 - posizione ambra e bianca
Luz de largo alcance R112 - Destello ámbar R65 - Posición ámbar y blanco

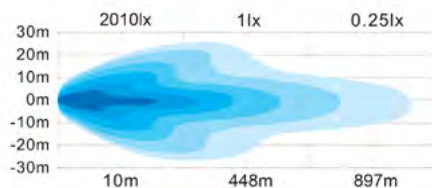

NEW



D16052 13"

Phare longue portée R112
Luce a lunga portata R112
Luz de largo alcance R112

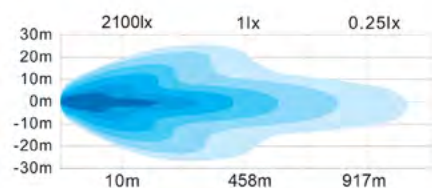

NEW



D16053 10"

Phare longue portée R112
Luce a lunga portata R112
Luz de largo alcance R112

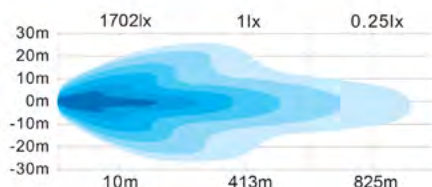

LED BARS ECO



NEW

LED



10/30V



IP67



D16040 425 mm



D16041 630 mm

ALPHA 230 PRO LED

LED

12/24V
50W

3450 Lumen

IP68

NEW



D16122
(A2894A769300)

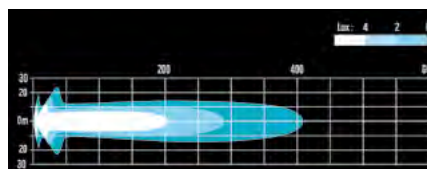
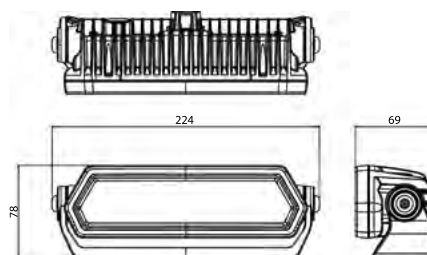

ALPHA 630 PRO LED

LED

12/24V
260W

15100 Lumen

IP68

NEW



D16123
(A2894A769400)

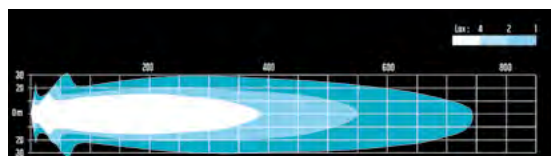
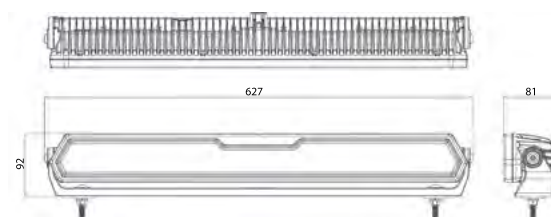

ALPHA 225 XENON



35W-D1S GEN5
24V
43 W

E4 16903

* lampe fournje - con lampadina - lampará incluida

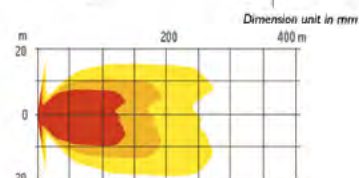
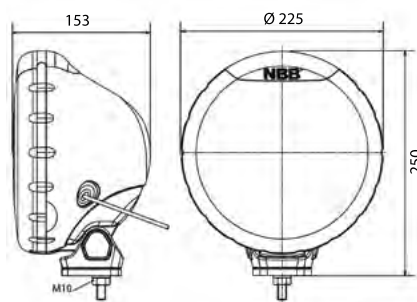

D14165*
(A0331A657300)

ALPHA 225



H1-12/24V
70W Max

E4 16902

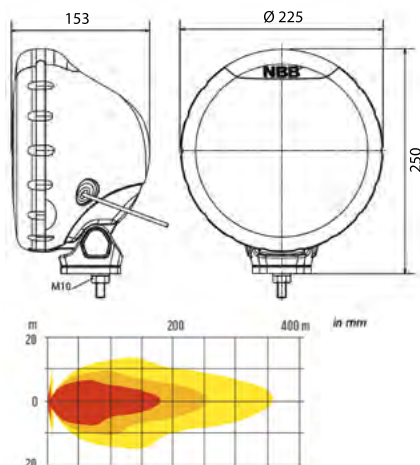

D14166
(A0330A657400)

AUXILIARY



NEW

LED

12/24V
108W

IP69K

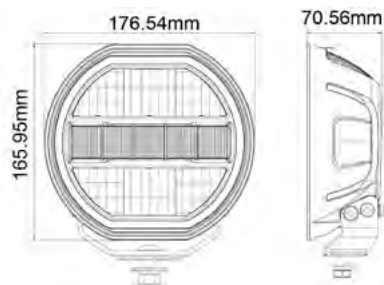

D16077 7"

Phare longue portée R149 - Position ambre et blanc
Luce a lunga portata R149 - posizione ambra e bianca
Luz de largo alcance R149 - Posición ámbar y blanco

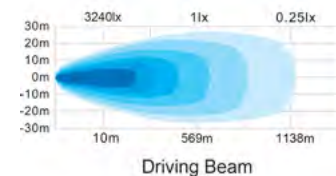

SEARCHLIGHT



NEW

360°

LED

10/30V

IP67



D16067

Pilotage télécommande
Telecomando
Control remoto

360°



D16068

Pilotage télécommande ou smartphone
Controllo tramite telecomando o app per smartphone
Control por mando a distancia o aplicación para smartphone

Éclairage intérieur

Illuminazione interna

Iluminación interior



DT-2P-M

Type connecteur - Nb pins - Mâle ou Femelle
Tipo di connettore - Num pin - Maschio o Femmina
Tipo de conector - Num pines - macho o hembra



Flashez le QR code pour plus d'infos
Scansiona il codice QR per maggiori informazioni
Escanee el código QR para obtener más info



Pièces détachées
Ricambi
Repuestos

RCL 1200



LED

9-30V

1200 Lumen

R10

IP6K9K

fils nus - estremità cavo nuda
- cable pelado

Affectations constructeurs
Applicazione primo impianto
Afectación primer equipo

LAMBERET p. 44

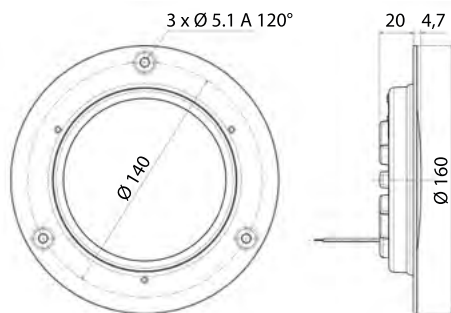

300010 6 LEDS



300000 6 LEDS
chromé - cromato - cromado

FE02



W5W - 12/24V

ADR



E₂ 7102

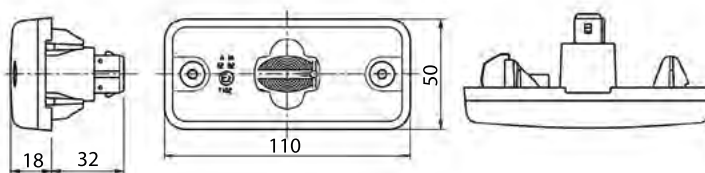

102200 K
clippé - fissaggio con clip - fijación con clip



D13876 JPT-2P-F



001726

2250



LED

10-30V

R10

IP69

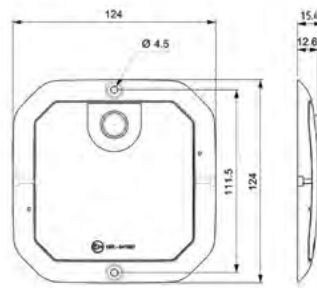
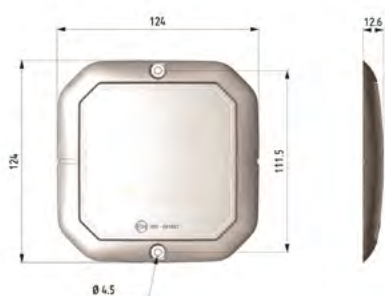

> 4 m <
timer 5 min

500 Lumen

D14569
(22.50.LP4.VLG) 4 LEDS - PIR

Avec détecteur de mouvement et chaleur (capteur PIR) - Con rilevatore di movimento e calore (PIR) - Con detector de movimiento y calor (PIR)



> 4 m <
timer 5 min

500 Lumen

MASTER
D14598
(22.50.LP4.MSV) 4 LEDS - PIR

Avec détecteur de mouvement et chaleur (capteur PIR) - Con rilevatore di movimento e calore (PIR) - Con detector de movimiento y calor (PIR)



500 Lumen

D14567
(22.50.L04.VLG) 4 LEDS

Sans détecteur de mouvement et chaleur (capteur PIR) - Senza rilevatore di movimento e calore (PIR) - Sin detector de movimiento y calor (PIR)



750 Lumen

D14568
(22.50.L06.VLG) 6 LEDS

Sans détecteur de mouvement et chaleur (capteur PIR) - Senza rilevatore di movimento e calore (PIR) - Sin detector de movimiento y calor (PIR)

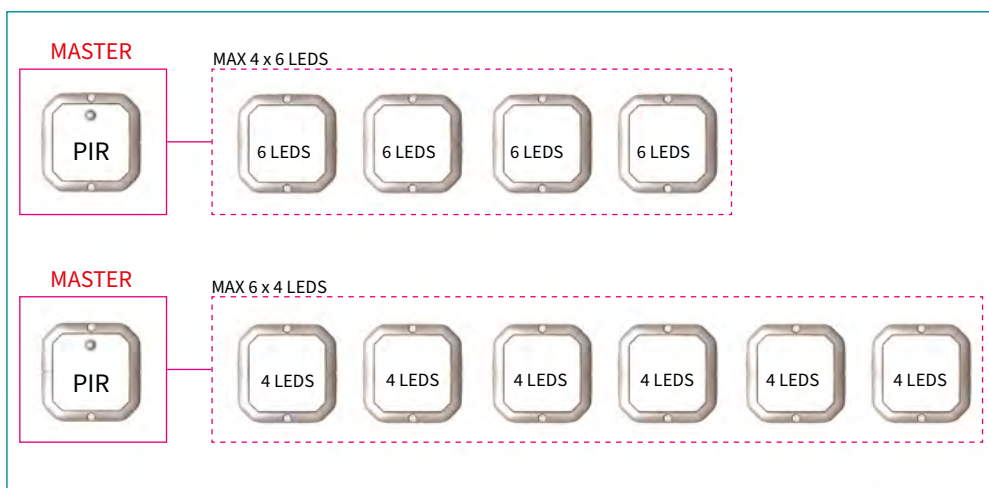

Exemple de montage Maître (PIR) + Esclaves -
Esempio di montaggio Master (PIR) + Schiavi -
Ejemplo de montaje Maestro (PIR) + Esclavos

SESA ZENITH



LED

12/24V

R10



IP67

filis nus - estremità cavo nuda
- cable pelado

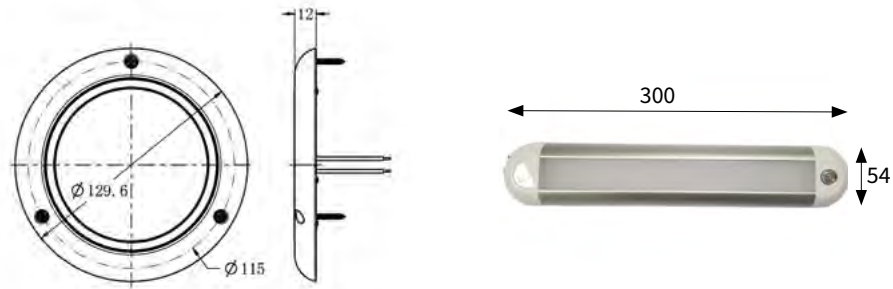

NEW



D16010

NEW



D16093

Bouton tactile - Tasto a sfioramento - Pulsador táctil

LED STRIP



LED

24V



IP68

NEW

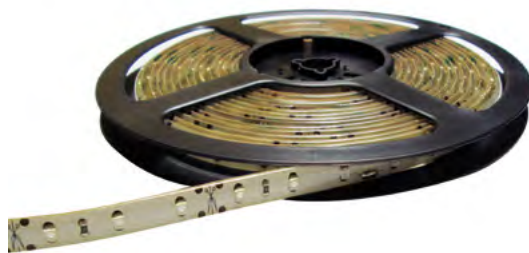

D16030

5 m



Gyrophares

Girofari

Luces rotativas

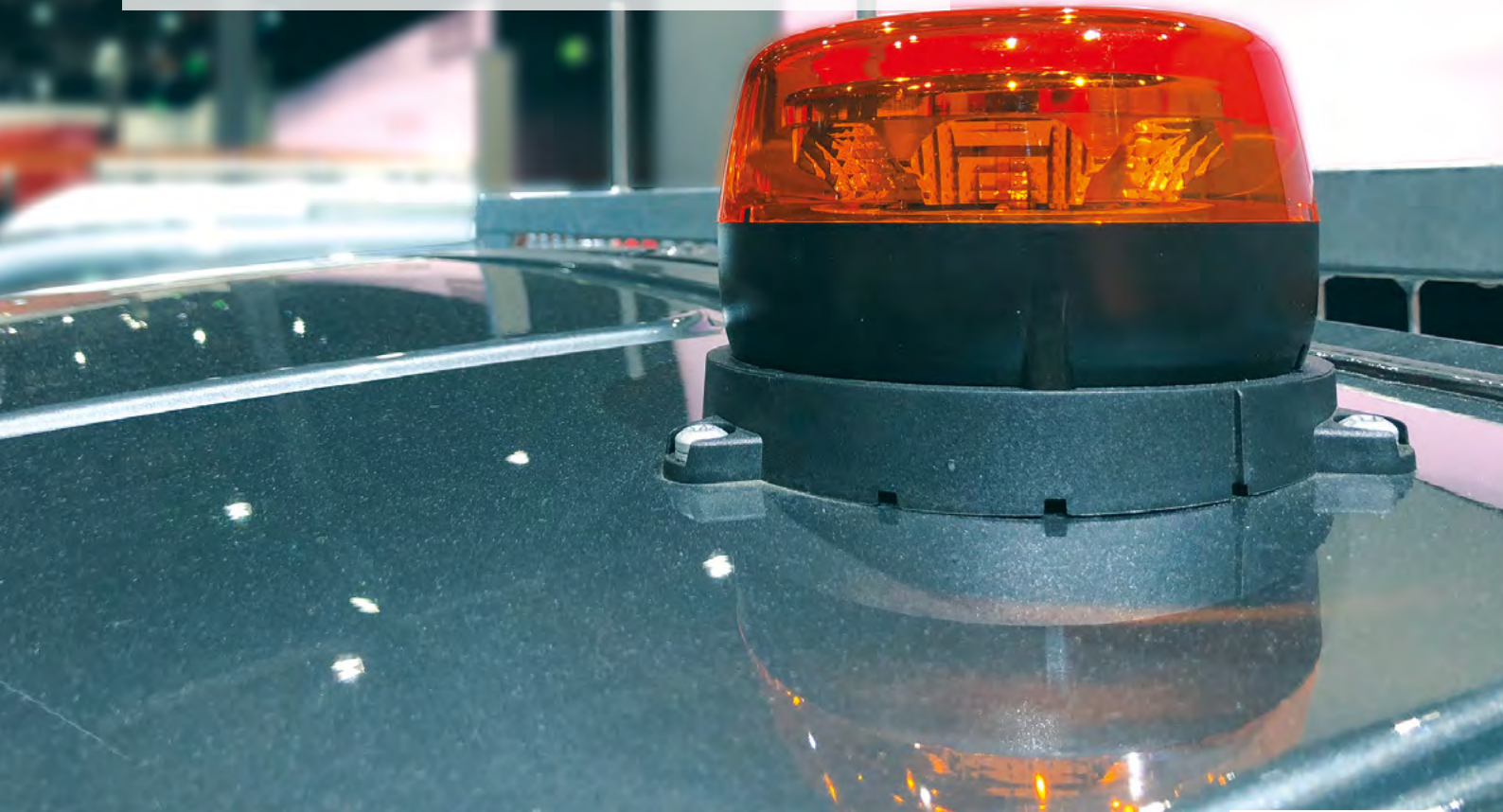

LED

p. 219-228



Halogène

p. 229



 Montage sur tige
Supporto tubolare DIN
Montaje de DIN

 Fixation à visser
Fissaggio a vite
Fijación por tornillo

 Magnétique
Magnético
Magnético

 LED Rotatif
LED Rotativo
LED Giratorio

 LED à éclats
LED Lampeggiante
LED Flash

 Polycarbonate
Policarbonato
Policarbonato



Flashez le QR code pour plus d'infos
Scansiona il codice QR per maggiori informazioni
Escanee el código QR para obtener más info



Indice de protection IP - solides/liquides
Protezione IP - solidi/liquidi
Protección IP - sólidos/líquidos



Pièces détachées
Ricambi
Repuestos



Homologation circulation réseau routier public
Omologazione circolazione su strada
Homologación circulación por carretera



Homologation CEM - compatibilité électromagnétique
Omologazione EMC - compatibilità elettromagnetica
Homologación CEM - compatibilidad electromagnética



Accessoires p. 230
Accessori p. 230
Accesorios p. 230

ATLASSINO

LED

10/30V
10 W - 16 W

R65 R10

SAE

IP6K9K

PC



Le gyrophare R65 le plus compact

Il più compatto lampeggiante R65
La luz destellante R65 más compacta

Double flash extra lumineux

Doppio flash extra-luminoso
Doble flash extra luminoso

LED puissante longue durée

LED potente e di lunga durata
LED potente de larga duración

Heavy duty - excellente résistance aux vibrations

Heavy duty : excellente resistenza alle vibrazioni
Heavy duty : gran resistencia a las vibraciones

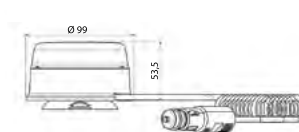
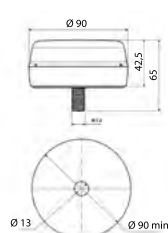
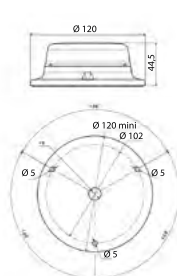
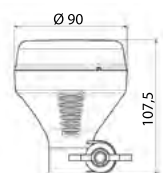

NEW



221300

CEM Class 5



NEW



221100 cable central

221200 cable lateral

fils nus - extrémité cavo nuda - cable pelado
CEM Class 5



NEW



221000

fils nus - extrémité cavo nuda - cable pelado
CEM Class 5



NEW



221500

CEM Class 5



Autres couleurs sur demande
Altri colori su richiesta
Ref. a petición

Gyrophares - Girofari - Luces rotativas

ATLAS



LED

10/30V
11 W - 17 W

✓ R65 ✓ R10

✓ SAE



IP6K9K



Affectations constructeurs
Applicazione primo impianto
Afectación primer equipo

DE BUF p. 25

MAN p. 52

MERCEDES p. 55

RENAULT TRUCKS p. 63

VOLVO p. 101

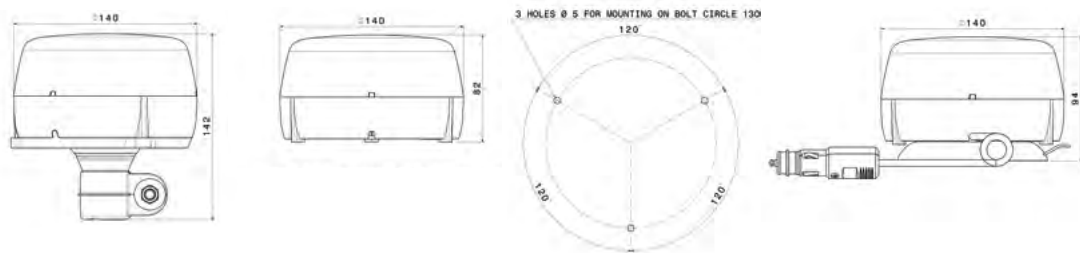

NEW



212420



212460



CEM Class 5



212400



CEM Class 3



211000



CEM Class 5
MONOBLOC



212120



212160



fils nus - estremità cavo nuda - cable pelado
CEM Class 5



212020



CEM Class 5
MAN p. 52

POS-2P-M



212730



CEM Class 5
VOLVO p. 104

TYCO MCON-2P-M



212710



CEM Class 5
MERCEDES p. 55

MQS-2P-M



212010



CEM Class 4
MERCEDES p. 56

KOSTAL-2P-M



212740



CEM Class 5
RENAULT TRUCKS p. 63

AMP-4P-F



212520



212560



CEM Class 5



Durée de vie optimale - Gestion thermique des Leds
- CEM Classe 3-5

Durata ottimale - Gestione termica dei LED - Classe
EMC 3-5

Vida útil óptima - Gestión térmica de los LED - CEM
Clase 3-5

ATLAS



LED

10/30V
11 W - 17 W

✓ R65 ✓ R10

IP69



Affectations constructeurs
Applicazione primo impianto
Afectación primer equipo

RENAULT TRUCKS p. 63
VOLVO p. 101

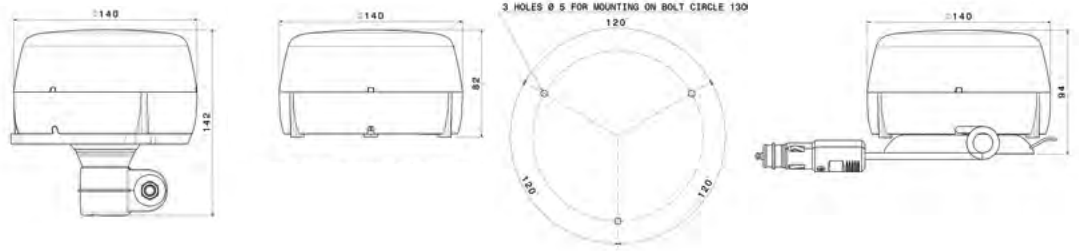

212470



CEM Class 5



212030



CEM Class 5
MAN p. 52

POS-2P-M



212170



CEM Class 5
fils nus - estremità cavo nuda - cable pelado



212570



CEM Class 5



212750*



CEM Class 5
RENAULT TRUCKS p. 63

AMP-4P-F

PEGASUS



LED

10/30V
9 W

✓ R65

✓ R10



* Multifunzione - Multifunción
** Rotativo - Giratorio

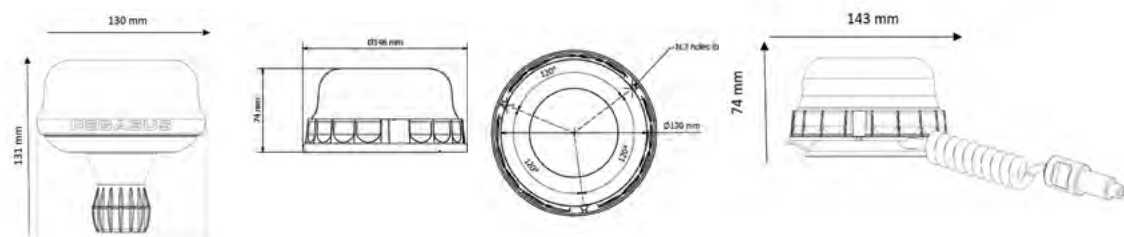

3 Types de flash homologués ECE R65
3 tipi di flash omologati ECE R65
3 tipos de flash homologadas ECE R65



FLASH



DOUBLE FLASH - DOPPIO FLASH -
DOBLE FLASH



ROTATIF - ROTATIVO - GIRATORIO



FLEXI

D14501
(21.50.L75.5V8) Multifonction*

D14725
(21.50.L75.3V8) Rotatif**



D14500
(21.50.L35.5V8) Multifonction*

D14724
(21.50.L35.3V8) Rotatif**



D14502
(21.50.LV5.5V8) Multifonction*

D14726
(21.50.LV5.3V8) Rotatif**



D14503
(21.50.811.MUV) Multifonction*

cabochon - calotta - tulipa



FLEXI

D14757
(21.50.L75.51V) Multifonction*



D14756
(21.50.L35.51V) Multifonction*



D14758
(21.50.LV5.51V) Multifonction*



D14747
(21.50.201.MUV) Multifonction*

cabochon - calotta - tulipa



GALAXY LED



LED

10/30V
9 W

✓ R65 ✓ R10

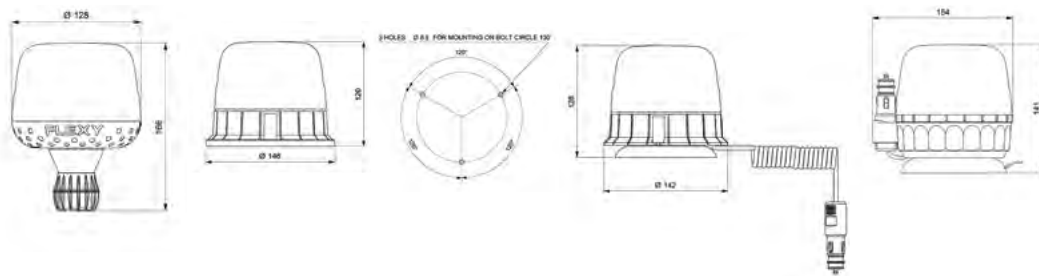

FLEXI

D14488
(21.49.L75.3V8)



D14487
(21.49.L35.3V8)



D14489
(21.49.LV5.3V8)



D14493
(21.49.L75.1V8)



D14492
(21.49.L35.1V8)



D14494
(21.49.LV5.1V8)



D14490
(21.49.LR5.3V8)



D14495
(21.49.LR5.1V8)



ROLL CABLE



D14755
(21.49.LR5.11V)



ROLL CABLE



FLEXI

D14753
(21.49.L75.11V)



D14752
(21.49.L35.11V)



D14754
(21.49.LV5.11V)



D14491
(2149.815.RTV)



D14496
(2149.815.LMV)



cabochon - calotta - tulipa



D14779
(21.49.801.VLG)



cabochon - calotta - tulipa

E-VENUS LED

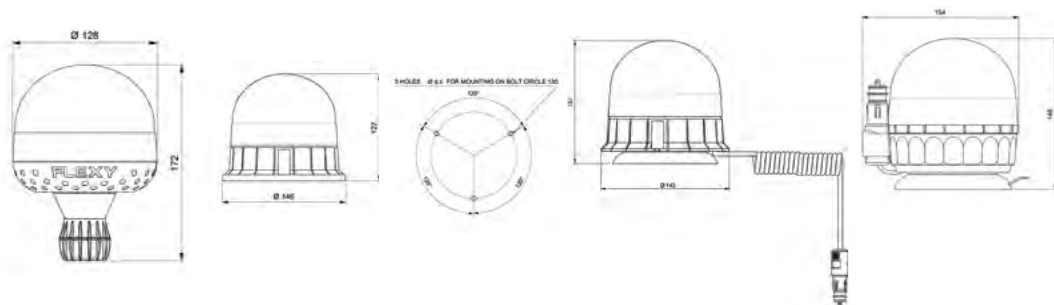

LED

10/30V
9 W

R65 R10



made w/solar elec

NEW



FLEXI

D16151



NEW



D16150



NEW



D16152



NEW



D16153



D16161

cabochon - calotta - tulipa

VEGA LED

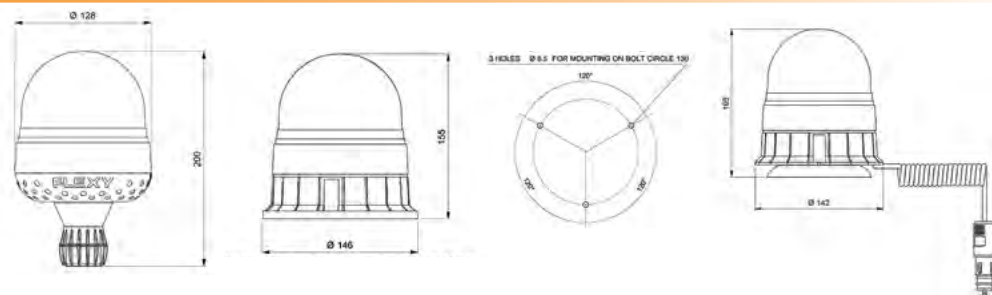

LED

10/30V
9 W

R65 R10



D14508
(21.87.L75.3V8)



D14507
(21.87.L35.3V8)



D14509
(21.87.LV5.3V8)



D14510
(21.87.815.RTV)

cabochon - calotta - tulipa



Montage sur tige
Supporto tubolare DIN
Montaje de DIN



Fixation à visser
Fissaggio a vite
Fijación por tornillo



Magnétique
Magnetico
Magnético



LED Rotatif
LED Rotativo
LED Giratorio



LED à éclats
LED Lampeggiante
LED Flash

TAURUS LED



LED

10/30V
9 W

R65 R10

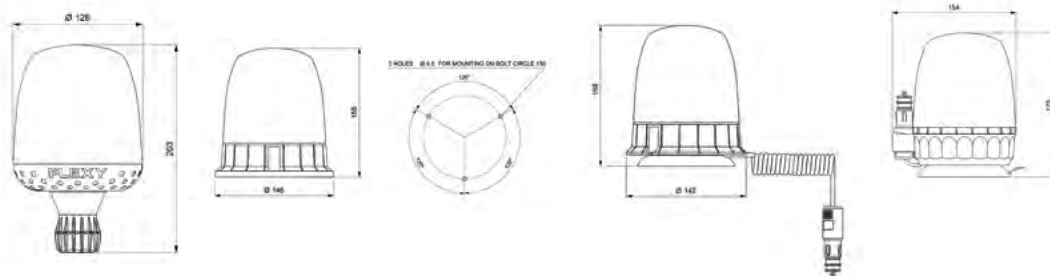

FLEXI

D14483
(21.48.L75.3V8)



D14482
(21.48.L35.3V8)



D14485
(21.48.LV5.3V8)



D14484
(21.48.LR5.3V8)

ROLL CABLE

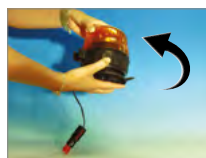

D14734
(21.48.LR5.15V)

ROLL CABLE



FLEXI

D14733
(21.48.L75.15V)



D14732
(21.48.L35.15V)



D14735
(21.48.LV5.15V)



D14486
(2148.815.RTV)

cabochon - calotta - tulipa



D14736
(2148.855.LMV)

cabochon - calotta - tulipa

SATURNELLO LED

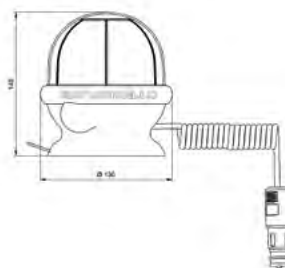
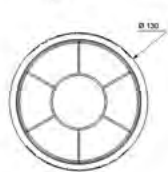

LED

10/30V
9 W

✓ R65 ✓ R10



FLEXI

D14737
(21.88.L85.3V8)



D14738
(21.88.LV5.3V8)



D14739
(21.88.815.VLG)

cabochon - calotta - tulipa

MINI SATURNELLO LED

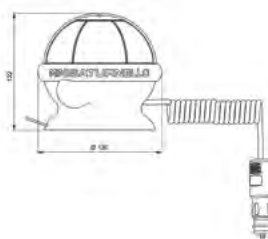
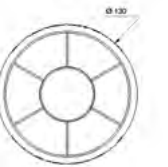

LED

10/30V
9 W

✓ R65 ✓ R10



FLEXI

D14740
(21.83.L85.3V8)



D14741
(21.83.LV5.3V8)



D14742
(21.83.815.VLG)

cabochon - calotta - tulipa

PUCK



LED

10/30V
3,5 W

R10

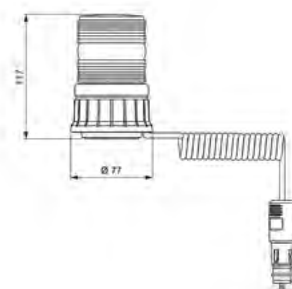
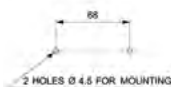
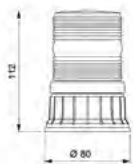
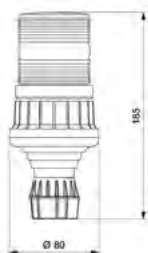

FLEXI

D14453
(21.38.L75.2VL)



D14451
(21.38.L35.2VL)



D14452
(21.38.LM5.2VL)



COMPACT - COMPACTO



FRESNEL



LED

10/110V
3,5 W

R10

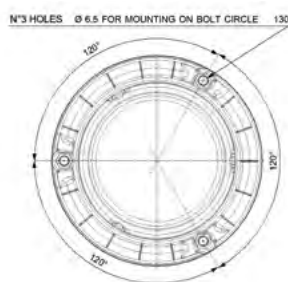
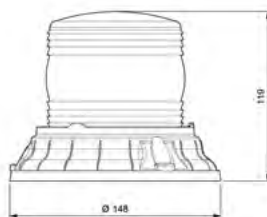

D14746
(21.37.L35.2VL)

AUTONOMOUS

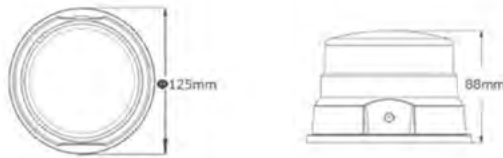

LED

10/30V
9 W

✓ R65 ✓ R10



NEW



D16012
(SM FL 104.OR.AUT)



Magnétique et sur batterie rechargeable, Câble de rechargement fourni.

Batteria magnetica e ricaricabile, cavo ricaricabile incluso.

Batería magnética y recargable, cable de carga USB incluido.

WARNING SIGNAL



NEW

LED



D16028



Magnétique et sur batterie rechargeable, Câble de rechargement fourni.

Batteria magnetica e ricaricabile, cavo ricaricabile incluso.

Batería magnética y recargable, cable de carga USB incluido.

TAURUS



H21W

12/24V
23W



lampes 12/24V fournies - con lampadine 12/24V - lamparás incluidas 12/24V

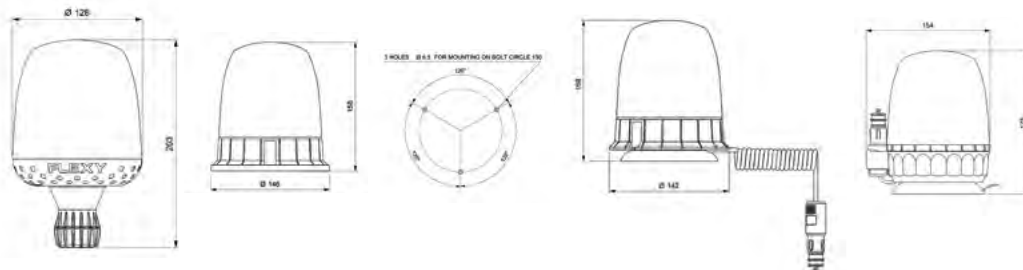

FLEXI

D14470
(21.48.H75.VLG)



D14467
(21.48.H35.VLG)



D14468
(21.48.HV5.VLG)



D14469
(21.48.HR5.VLG)



ROLL CABLE



D14471
(21.48.811.VLG)

cabochon - calotta - tulipa

VEGA



H1

12/24V
55-70W



lampes 12/24V fournies - con lampadine 12/24V - lamparás incluidas 12/24V

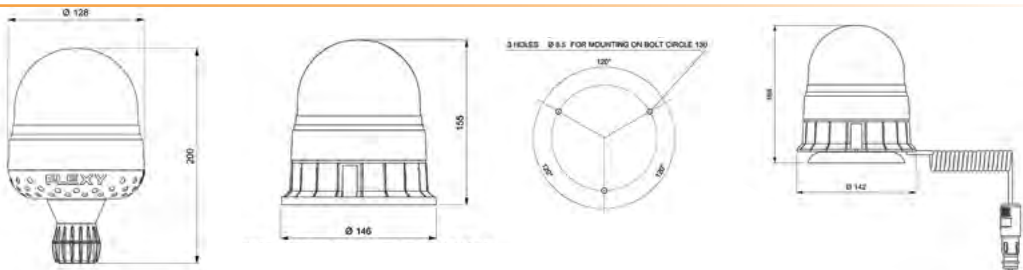

D14479
(21.87.T75.VLG)



D14477
(21.87.T35.VLG)



D14478
(21.87.TV5.VLG)



D14480
(21.87.811.VLG)

cabochon - calotta - tulipa



Exemple de montage - Esempio di montaggio - Ejemplo de montaje



D14514
(21.92.000.VLG)

tige avec support central - supporto con staffa centrale - varilla con soporte central
ISO 4148/4165



D14513
(21.91.000.VLG)

tige à visser - supporto da avvitare - varilla para atornillar
ISO 4148/4165

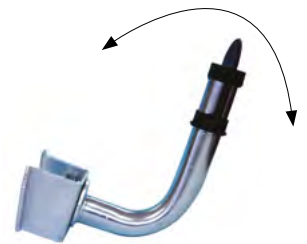

D14515
(21.97.005.VLG)

tige articulée 360° - supporto orientabile 360° - varilla rotativa 360°
ISO 4148/4165



D14511
(21.76.282.VLG)

semelle plate - base piatta - base plana



D14512
(21.76.283.VLG)

semelle inclinée - base inclinada - base inclinada



Exemple de montage - Esempio di montaggio - Ejemplo de montaje

STELLAR



LED

10/36V

R65

R10

SAE



IP6K9K



Performance lumineuse homologuée R65

*R65 prestazione luminosa approvata
Rendimiento luminoso homologado R65*

Design extra plat et aérodynamique

*Design ultrapiatto e aerodinamico
Diseño extraplano y aerodinámico*

Qualité «best in class» constructeurs

*Qualità insuperabile
La mejor calidad de producto*

Polycarbonate ultra robuste

*Policarbonato ultra resistente
Policarbonato ultrarresistente*



VIDEO YOUTUBE

Autres options et versions disponibles sur demande :

- Bleu véhicules prioritaires et d'urgences
- Phares de travail avant, arrière, latéraux
- Rappel stop, position, indicateur de direction
- Traffic master
- Interface véhicule mécanique et électronique
- Centre blanc opaque avec texte

Altre opzioni e versioni disponibili su richiesta:

- Veicoli prioritari e di emergenza
- Fari da lavoro anteriori, posteriori, laterali
- Fanale stop, posizione, indicatore di direzione
- Modulo sequenziale posteriore
- Interfaccia veicolo meccanica ed elettronica
- Centro bianco opaco con testo

Otras opciones y versiones disponibles bajo pedido :

- Vehículos de emergencia y prioritarios
- Faros de trabajo y proyector delanteros, traseros, laterales
- Stop adicional, posición, intermitente
- Control del tráfico
- Interfaz de vehículo mecánica y electrónica
- Centro opaco blanco con texto

STELLAR



LED



10/36V



IP6K9K

Câble fils nus - estremità cavo nuda - cable pelado



D23301 950 mm

R65 ambre - ambra - ámbar



D23401 1250 mm

R65 ambre - ambra - ámbar



D23501 1550 mm

R65 ambre - ambra - ámbar



D23513 1550 mm

R65 ambre - Stop/Position/Indicateur de direction - Phares de travail avant et latéraux
 R65 ambra - Stop/posizione/direzione - Fari da lavoro anteriori e laterali
 R65 ámbar - Stop/posición/dirección - Luces de trabajo delanteras y laterales

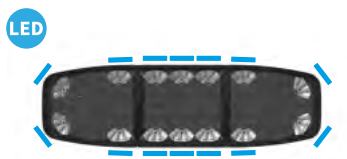

D23354 950 mm

R65 bleu - blu - azul

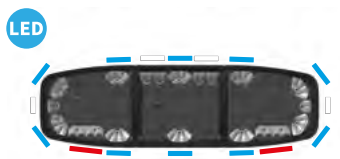

D23363 950 mm

R65 bleu - Stop/Position/Indicateur de direction - Phares de travail avant et latéraux
 R65 blu - Stop/posizione/direzione - Fari da lavoro anteriori e laterali
 R65 azul - Stop/posición/dirección - Luces de trabajo delanteras y laterales



D16058



D16035

Triflash



LED à éclats
LED Lampeggiante
LED Flash



Polycarbonate
Polycarbonato
Polycarbonato



Pièces détachées
Ricambi
Repuestos



Flashez le QR code pour plus d'infos
Scansiona il codice QR per maggiori informazioni
Escanee el código QR para obtener más info



Indice de protection IP - solides/liquides
Protezione IP - solidi/liquidi
Protección IP - sólidos/líquidos



Homologation circulation réseau routier public
Omologazione circolazione su strada
Homologación circulación por carretera



Homologation CEM - compatibilité électromagnétique
Omologazione EMC - compatibilità elettromagnetica
Homologación CEM - compatibilidad electromagnética

TRIFLASH 500 CEA



LED

10/30V
9,5 W

R10 NF EN 12352

PC/ABS

IP6K9K

< 3,5t



* kit de relevage manuel inclus - Sollevamento manuale incluso - Elevador manual incluido

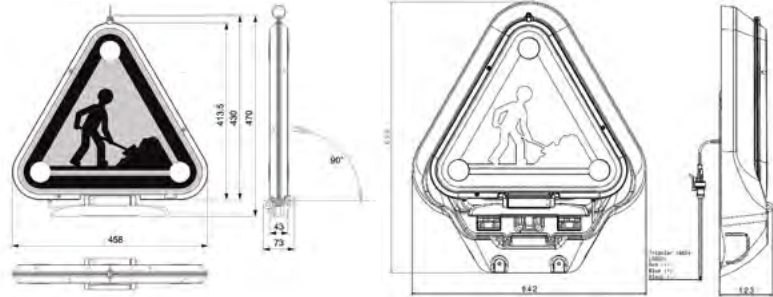

Symbole AK5 - Compact - Léger (3,15 Kg) - Homologué
Simbolo AK5 - Compatto - Leggero (3,15 Kg) - Omologato
Símbolo AK5 - Compacto - Ligero (3,15 Kg) - Homologado



D14760 *
(2090L51200)



Classe 1 : ville et route nationale - strade urbane - Ciudad y carreteras nacionales



D14762 *
(2090L52200)



Classe 2 : autoroutes et voies rapides - strade extraurbane - autovías

NEW

ELEC



D14925
(2090L5220E)



Classe 2 : autoroutes et voies rapides - strade extraurbane - autovías

TRIFLASH 700 CEA



LED

10/30V
9,5 W

R10 NF EN 12352

PC/ABS

IP6K9K

> 3,5t



* kit de relevage manuel inclus - Sollevamento manuale incluso - Elevador manual incluido
vignal-group.com



D14926 *
(2090L72200)



Classe 2 : autoroutes et voies rapides - strade extraurbane - autovías

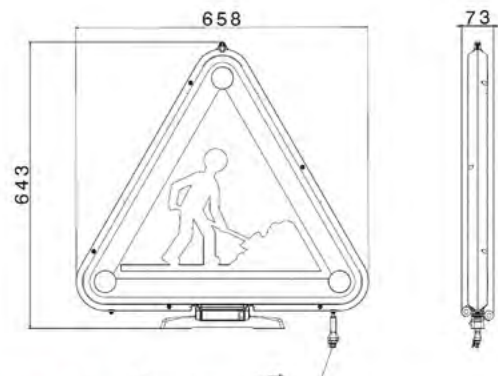

LED à éclats
LED Lampeggiante
LED Flash

TRIFLASH ACC CEA



LED

10/30V
9,5 W

✓ R65 ✓ R10



IP6K9K

Exemple de montage D14762 + D14930
Esempio di montaggio D14762 + D14930
Ejemplo de montaje D14762 + D14930



D14932
(2090L1B110)

Pour Triflash avec 1 gyrophare LED
Per Triflash con 1 girofaro LED
Para Triflash con 1 rotativo LED

D14933
(2090L1B136)

Pour Triflash avec 1 gyrophare LED
Per Triflash con 1 girofaro LED
Para Triflash con 1 rotativo LED

D14934
(2090L1B151)

Pour Triflash avec 1 gyrophare LED
Per Triflash con 1 girofaro LED
Para Triflash con 1 rotativo LED



D14929
(2090L2B110)

Pour Triflash avec 2 gyrophares LED
Per Triflash con 2 girofari LED
Para Triflash con 2 rotativos LED

D14930
(2090L2B136)

Pour Triflash avec 2 gyrophares LED
Per Triflash con 2 girofari LED
Para Triflash con 2 rotativos LED

D14931
(2090L2B151)

Pour Triflash avec 2 gyrophares LED
Per Triflash con 2 girofari LED
Para Triflash con 2 rotativos LED



D14935
(2090L2B181)

Pour Triflash avec 2 gyrophares LED
Per Triflash con 2 girofari LED
Para Triflash con 2 rotativos LED



D14928
(2090805000)

Kit de relevage manuel pour -
Sollevamento manuale incluso per -
Elevador manual para D14760 - D14762 - D14926



D14922
(209080U000)

Support universel - Pattes de fixation pour barre Triflash.
Staffa universale fissaggio per barra Triflash.
Soporte de montaje universal para barra Triflash.



D14989
(2090804000)

Kit de fixation sur barre pour Triflash électrique D14925.
Kit montaggio barra per Triflash elettrico D14925.
Kit de montaje sobre barra para Triflash eléctrico D14925.

TLP 500 SESALY



Symbole AK5 - Haute intensité lumineuse - référencé chez Orange, Ville de Paris, EDF, GDF, SNCF
 Simbolo AK5 - Alta intensità luminosa - scelto dalle principali flotte di energia e trasporto
 Símbolo AK5 - Alta intensidad luminosa - elegido por las principales flotas de energía y transporte

LED

12/24V
3,2 W

R10 NF EN 12352

IP6K9K

< 3,5t

NEW



D16001
(TLP 500 CL2)



Classe 1 : ville et route nationale - strade urbane - Ciudad y carreteras nacionales

NEW

ELEC



D16003
(TLP 500-ELEC.CL2)



Classe 2 : autoroutes et voies rapides - strade extraurbane - autovías

NEW



Ref sur demande
P/N su richiesta - Ref. a petición

TLP 700 SESALY



LED

10/30V
9,5 W

R10

PC/ABS

IP6K9K

>3,5t

NEW



D16034
(TLP 700 CL2)



Classe 2 : autoroutes et voies rapides - strade extraurbane - autovías

Feux de pénétration

Luci direzionali

Luces direccionales



Flashez le QR code pour plus d'infos
Scansiona il codice QR per maggiori informazioni
Escanee el código QR para obtener más info



Indice de protection IP - solides/liquides
Protezione IP - solidi/liquidi
Protección IP - sólidos/líquidos



Pièces détachées
Ricambi
Repuestos



Homologation circulation réseau routier public
Omologazione circolazione su strada
Homologación circulación por carretera



Homologation CEM - compatibilité électromagnétique
Omologazione EMC - compatibilità elettromagnetica
Homologación CEM - compatibilidad electromagnética



Polycarbonate
Policarbonato
Policarbonato

Feux de pénétration - Luci direzionali - Luces direccionales

SESA PULSAR



LED

12/24V
5,5 W

R65

R10



IP69K

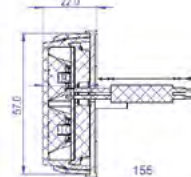
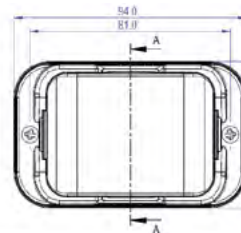
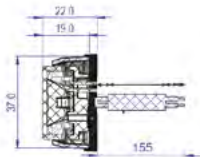
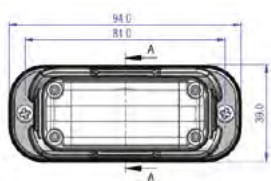

NEW

NEW



ECE R65-Class 1

ECE R65-Class 2

- D16004 ●
- D16056 ○
- D16005 ●
- D16075 ●

- D16018 ●
- D16017 ●
- D16076 dual color ● ●

Single (120 flash/min)	Double (120 flash/min)
Quad (120 flash/min)	Cruise

4 types de flash
4 tipi di flash
4 tipos de flash

DL LONG



LED

10/30V
12 W

R65

R10



IP67

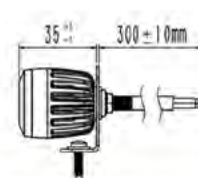
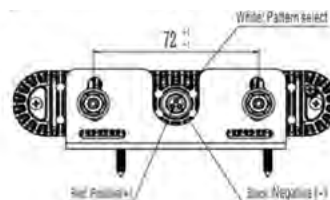

- D14190 ●
- D14354 ○
- D14353 ●

10 types de flash
10 tipi di flash
10 tipos de flash

One Flash (600ms)	In turn Double Flash (800ms)
In turn 4 Flash (800ms)	3 Flash (600ms)
5 Flash (1000ms)	1 Flash (960ms)
In turn 3 Flash (600ms)	Unique (410ms)
Frequent Flash (60ms)	Combination



Alternative flash ← →

GUARDIAN ANGEL



LED

360°



IP68



NEW



D16038



NEW



D16039

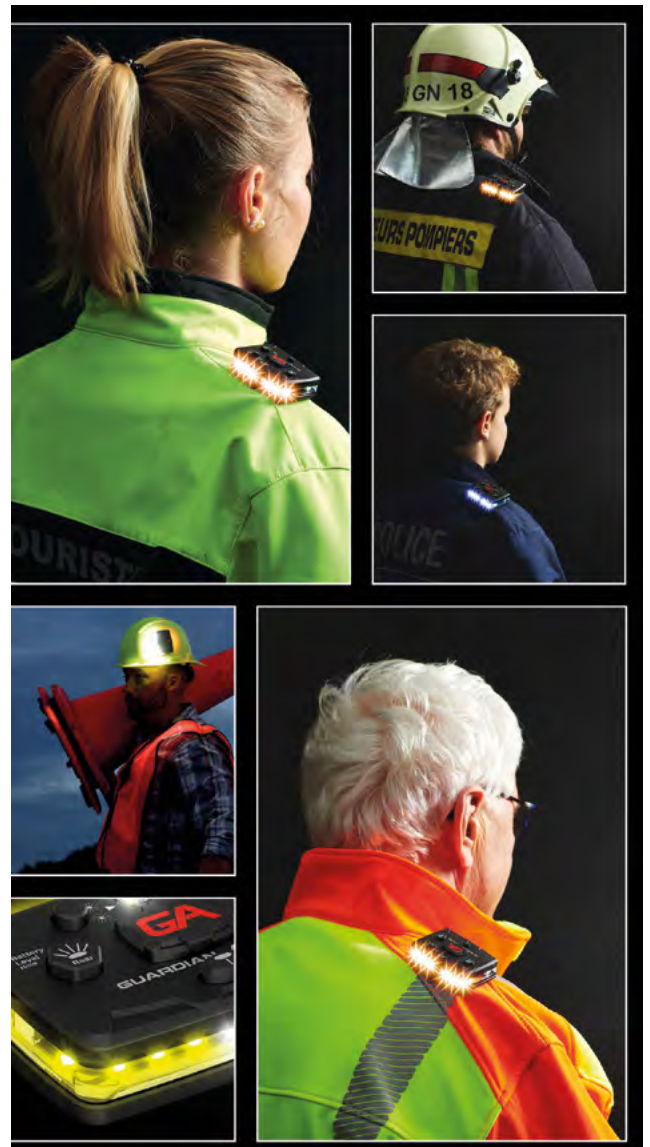

Alarmes sonores de recul

Cicalini retromarcia

Alarmas sonoras de marcha atrás



Standard



Multi-Frequency



Flashez le QR code pour plus d'infos
Scansiona il codice QR per maggiori informazioni
Escanee el código QR para obtener más info



Indice de protection IP - solides/liquides
Protezione IP - solidi/liquidi
Protección IP - sólidos/liquidos



Pièces détachées
Ricambi
Repuestos



Homologation CEM - compatibilité électromagnétique
Omologazione EMC - compatibilità elettromagnetica
Homologación CEM - compatibilidad electromagnética

ASR



STANDARD - ESTÁNDAR

102 mm x 71 mm x 41 mm

Standard



1. Chariots élévateurs, petits camions, VUL
Carelli elevatori, veicoli industriali, veicoli commerciali leggeri
Carretillas elevadoras, pequeños camiones, vehículos comerciales ligeros
2. Toute utilisation. Ajustement automatique 10 db supérieur au bruit ambiant
Universale. Regolazione automatica superiore di 10 db al rumore dell'ambiente esterno
Universal. Ajuste automático a 10 db más arriba que el ruido del entorno exterior
3. Benne à ordure, chantier, forêt, PL
Veicoli raccolta rifiuti, apparecchiature e veicoli di cantiere, apparecchiature e veicoli forestali, camion
Dumpers, volquetes, basculas, maquinarias forestales, camiones



12/24V



630120 : SAE Type D
630100 : SAE Type F
D13807 : SAE Type D
D13808 : SAE Type C

1	630120	87 db
2	630110	82-102 db
3	630100	102 db



IP65

MULTI-FRÉQUENCE - MULTI-FREQUENZA - MULTI-FRECUENCIA



102 mm x 71 mm x 41 mm

Multi-Frequency



D13807	87 db
D13808	97 db

Multi-Frequency



D13810	97 db 1500 mm
---------------	------------------

CLICK-IN



24V

MULTI-SON - MULTI-SUONO - MULTISONIDO

NEW



Beep Beep
Sshrrr Sshrrr

D16074	97 db
---------------	-------

Multi-fréquence ou standard
Multi-frequenza o standard
Multi-frecuencia o estandar

ASR



INTÉGRÉE - INCASSATO - INCORPORADO



001830 90 db

Pour connection sur feu arrière LC8 p. 150
Per collegamento su fanale posteriore LC8 p. 150
Para acoplamiento con piloto trasero LC8 p. 150



001872 55-90db

Ajustement bruit ambiant sur feu arrière LC8 MAN p. 153
Regolazione dell'ambiente esterno fanale posteriore LC8 MAN p. 153
Ajuste al entorno exterior piloto trasero LC8 MAN p. 153



D12953 90 db

Pour connection sur feu arrière LC9 p. 160, LC7 p. 166
Per collegamento su fanale posteriore LC9 / LC7 p. 160 / p. 166
Para acoplamiento con piloto trasero LC9 / LC7 p. 160 / p. 166

SESA TUNES ADVANCED - AVAS



AVAS

FMVSS141
R138



Son AVAS homologué R138

Suono AVAS omologato R138
Sonido AVAS homologado R138

Idéal véhicules hybrides et électriques

Ideale per veicoli ibridi ed elettrici
Ideal para vehículos híbridos y eléctricos

Niveau de son ajustable et personnalisable

Livello sonoro regolabile e personalizzabile
Nivel de sonido ajustable y personalizable

Multifonctions : Son AVAS, alarme de recul, gong piéton

Multifunzione: suono AVAS, allarme di retromarcia, gong per i pedoni
Multifunción: sonido AVAS, alarma de marcha atrás, gong para peatones Policarbonato ultrarresistente

Systemes caméra Telecamere Sistemas de cámara

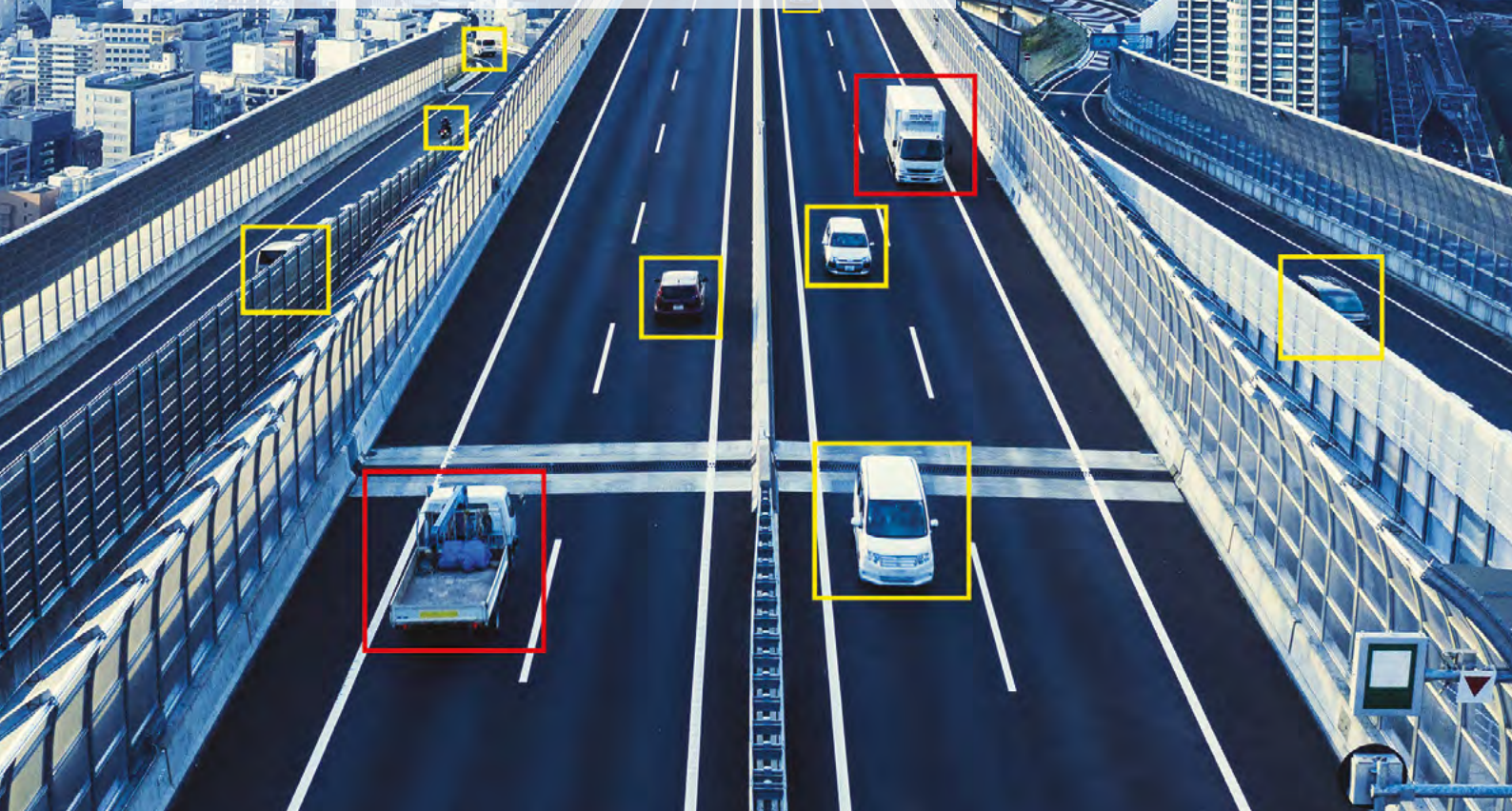

Systemes sans fil - Sistemi senza filo - Sistemas inalámbricos p. 244-245



Systemes filaires - Sistemi con filo - Sistemas cableados p. 246-250



Flashez le QR code pour plus d'infos
Scansiona il codice QR per maggiori informazioni
Escanee el código QR para obtener más info



Système HD
Sistema HD
Sistema HD



Indice de protection IP - solides/liquides
Protezione IP - solidi/liquidi
Protección IP - sólidos/líquidos



Écran tactile
Schermo touch screen
Pantalla táctil



Pièces détachées
Ricambi
Repuestos



Caméra vision nocturne
Telecamera per visione notturna
Cámara de visión nocturna



Taille écran
Grandezza schermo
Tamaño pantalla



Écran fractionné
Schermo diviso
Pantalla dividida



Système sans fil
Sistema senza filo
Sistema inalámbrico

CAM WIRELESS HD 2.4 GHz 7"



NEW



D16044

12/24V - Ecran fractionné couleur 7 pouces - transmission sans fil 2.4 GHz 300 m - Raccordement jusqu'à 4 caméras - **appairage automatique** - Enregistrement en temps réel - Support carte micro SD (non fournie) - Caméra micro intégré - vision de nuit - Utilisation entre -20°C et +70°C

12/24V - Multi schermi a colori 7 pollici - Trasmissione senza fili 2.4 GHz a 300 m - Collegamento fino a 4 camere - **Associazione automatica** - Registrazione in tempo reale - Supporto scheda micro SD - Camera con microfono - visione notturna - Usare tra -20°C e +70°C

12/24V - Pantalla color split 7 pulgadas - Transmisión inalámbrica 2.4GHz a 300 m- Conexión hasta 4 cámaras - **Auto Emparejamiento** - Grabación en tiempo real - Soporte de tarjetas SD - Cámara con micrófono - visión nocturna - Utilización entre -20°C et +70°C



TEMPS D'ENREGISTREMENT - TEMPO DI REGISTRAZIONE - TIEMPO DE GRABACIÓN :

MODE \ Micro SD	16G	32G	64G	128G
SINGLE (640x480x1)	≈ 15h	≈ 30h	≈ 60h	≈ 120h
QUAD (320x240x4)	≈ 17h	≈ 34h	≈ 68h	≈ 136h
SPLIT (400x480x2)	≈ 18h	≈ 36h	≈ 72h	≈ 144h

NOTICE DE BRANCHEMENT - ISTRUZIONI DI CONNESSIONE - INSTRUCCIONES DE CONEXIÓN :



rouge positif - rosso positivo - rojo positivo
 noir masse - nero massa - negro masa
 marron recul - marrone retromarcia - marrón marcha atrás
 blanc clignotant gauche - bianco indicatore a sinistra - blanco intermitente izquierda
 bleu clignotant droit - blu indicatore a destra - azul intermitente derecha
 vert ou jaune option - verde o giallo opzione - verde o amarilla opción



Les appareils 2.4 GHz tels que les téléphones cellulaires, les systèmes Bluetooth et Wi-Fi peuvent causer des interférences passagères. I dispositivi 2.4 GHz come cellulari, Bluetooth e Wi-Fi possono creare temporane interferenze. Los dispositivos 2.4 GHz como teléfonos celulares, sistemas Bluetooth y inalámbricos pueden causar interferencias temporales

ACC WIRELESS HD



COMPOSEZ VOTRE KIT SUR-MESURE
 CREA IL TUO KIT PERSONALIZZATO
 DISEÑA SU PROPIO KIT PERSONALIZADO



1. ECRAN - SCHERMO - PANTALLA

NEW



D16055

Ecran 7" - Schermo 7" - Pantalla 7"
 Fractionnable - Multi schermo - Dividida



2. CAMÉRA - CAMERA - CÁMARA

NEW



D16045

Aluminium
 Alluminio
 Aluminio

NEW



D16046

batterie rechargeable
 batteria ricaricabile
 batería recargable

NEW



D16126

Capot motorisé
 Autoscatto motorizzato
 Obturador automático motorizado



3. ACCESSOIRES - ACCESSORI - ACCESORIOS



D14063

7 m



D14326

antenne écran - antenna schermo - antena de pantalla



D14195

antenne caméra - antenna camera - antena de cámara



Exemple de montage - Esempio di montaggio - Ejemplo de montaje
 Kit D16044 + D16045 x 3

CAM WIRED HD 720P 7"

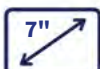

100°



20 m

NEW

D16033



12/24V - Ecran couleur 7 pouces - Raccordement possible pour 3 caméras - Caméra LED micro intégré - vision de nuit - Utilisation entre -20°C et +70°C

12/24V - Schermo a colori 7 pollici - Possibilità di collegamento a 3 camere- camera con microfono - visione notturna - Usare tra -20°C e +70°C

12/24V - Pantalla color 7 pulgadas - Conexión posible para 3 cámaras - Cámara de aluminio con micrófono - visión nocturna - Utilización entre -20°C y +70°C

NOTICE DE BRANCHEMENT D16033 - ISTRUZIONI DI CONNESSIONE - INSTRUCCIONES DE CONEXIÓN :

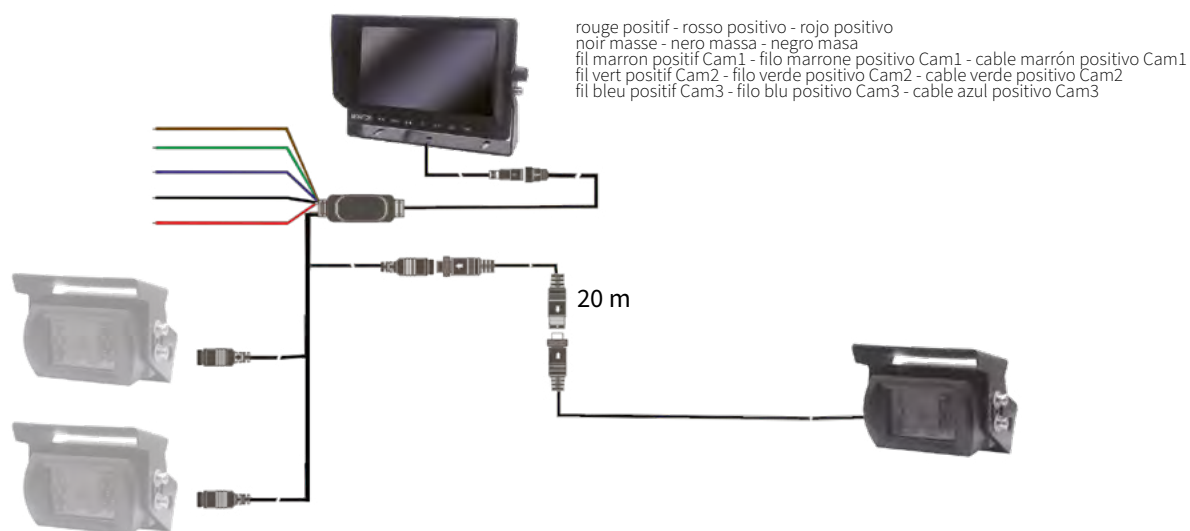

ACC WIRED



100°



D16043

Aluminium
Alluminio
Aluminio

150°



D14148

Slim grand angle
Compatta grandangolare
Compacta gran angular

120°



D14327

Motorisée + chauffante
Motorizzato + riscaldato
Motorizado + calefacción



D13620



D13621

10 m

D13622

20 m



Exemple de montage - Esempio di montaggio - Ejemplo de montaje
Kit D16033 + D13621 + D13620

CAM WIRED 720P AUTO SHUTTER 7"

 12/24V
10W

 R10

 
IP69K

 7" 
HD 720P



NEW

20 m

D16131

12/24V - Ecran couleur 7 pouces - Raccordement possible pour 3 caméras - Caméra LED avec capot motorisé et micro intégré - vision de nuit - Utilisation entre -20°C et +70°C

12/24V - Schermo a colori 7 pollici - Possibilità di collegamento a 3 camere - camera con autoscatto e microfono - visione notturna - Usare tra -20°C e +70°C

12/24V - Pantalla color 7 pulgadas - Conexión posible para 3 cámaras - Cámara de aluminio con obturador automático y micrófono - visión nocturna - Utilización entre -20°C y +70°C



ACC WIRED

 12/24V

HD 720P

120°



D16132

Capot motorisé
Autoscatto motorizzato
Obturador automático motorizado



D13620



D13621

10 m

D13622

20 m



CAM WIRED HD 1080P 7"



NEW

20 m

D16129



12/24V - Qualité d'image HD 1080P - Ecran quad HD 7" fractionnable - Raccordement jusqu'à 4 caméras - Caméra LED aluminium avec micro intégré - vision de nuit - Utilisation entre -20°C et +70°C

12/24V - Qualità dell'immagine HD 720P - Multi schermo quad HD 7" - Collegamento fino a 4 camere - Camera in acciaio con microfono - visione notturna - Usare tra -20°C e +70°C

12/24V - Calidad de imagen HD 720P - Pantalla quad HD 7" de vista múltiples - Conexión hasta 4 cámaras - Cámara de acero inoxidable con micrófono - visión nocturna - Utilización entre -20°C y +70°C

CAM WIRED HD 1080P 10"



NEW

20 m

D16130



12/24V - Qualité d'image HD 1080P - Ecran quad HD 10" fractionnable - Raccordement jusqu'à 4 caméras - Caméra LED aluminium avec micro intégré - vision de nuit - Utilisation entre -20°C et +70°C

12/24V - Qualità dell'immagine HD 720P - Multi schermo quad HD 10" - Collegamento fino a 4 camere - Camera in acciaio con microfono - visione notturna - Usare tra -20°C e +70°C

12/24V - Calidad de imagen HD 720P - Pantalla quad HD 10" de vista múltiples - Conexión hasta 4 cámaras - Cámara de acero inoxidable con micrófono - visión nocturna - Utilización entre -20°C y +70°C

ACC WIRED HD 1080P



12/24V

1. ECRAN - SCHERMO - PANTALLA



D16134

Ecran quad HD 7" fractionnable
- Multi schermo quad HD 7" -
Pantalla quad HD 7" de vista
múltiples



D16135

Ecran quad HD 10" fraction-
nable - Multi schermo quad HD
10" - Pantalla quad HD 10" de
vista múltiples



D16133

Aluminium - Alluminio - Alu-
minio

3. CÂBLAGE - CABLAGGIO - CABLEADO



D13620

Pour 1 caméra HD720P - Per
1 camera HD720P - Para 1
cámara HD 720P



D14685

Pour 2 caméras HD - Per 2 ca-
mere HD - Para 2 cámaras HD



D13621

10 m

D13622

20 m



5054

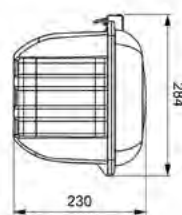
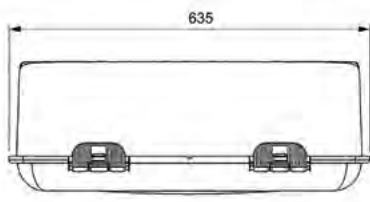

Max 6 kg

D14538
(50.52.925.TV2)

Avec sangle nylon - Con cinghie nylon - Con correa de nylon



Max 6 kg

D14539
(50.52.925.TVC)

Avec sangle CLIP réglable - Con cinghie di fissaggio regolabili CLIP - Con correa ajustable CLIP



NEW



Max 6 kg

D16163

5051

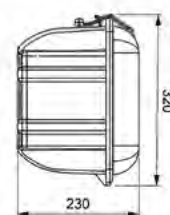
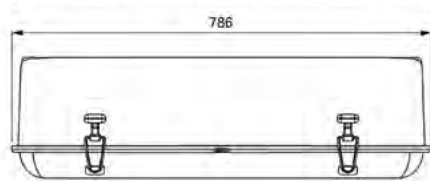

Max 9 kg

D14537
(50.51.020.VLG)

Avec sangle plastique - Con cinghie di plastica - Con correa de plástico

NEW



Max 9 kg

D16162

FIRE EXTINGUISHER



D16036

Inhibiteur de feu ultra compact - durée d'émission 50 secondes - durée de vie illimité (sans date de péremption) - sans entretien périodique
Estintore ultra compatto - tempo di emissione 50 secondi - durata illimitata (nessuna data di scadenza) - nessuna manutenzione periodica
Extintor ultracompacto - tiempo de emisión 50 segundos - vida ilimitada (sin fecha de caducidad) - sin mantenimiento periódico

Prises et câbles spiralés

Spine e spirali
Enchufes y espirales



Flashez le QR code pour plus d'infos
Scansiona il codice QR per maggiori informazioni
Escanee el código QR para obtener más info

7P



24V

24N (ISO 1185)
24S (ISO 3731)

MÉTALLIQUE - METALLICA - METÁLICA



D10873

24N



611530

24N



D10874

24S



611550

24S

PLASTIQUE - PLASTICA - PLÁSTICA



611500

24N



611580

24N



611510

24S



611590

24S



611520

24N



611540

24S

C7P



Longueur de travail : L
 Lunghezza di funzionamento : L
 Longitud de funcionamiento : L

LMax
 Longueur d'extension maximale
 :Massima lunghezza d'estensione
 Longitud máxima de extensión

MÉTALLIQUE - METALLICA - METÁLICA



D14313 LMax 3,5 m
611140 L : 3 m, LMax 4,5 m



D14314 LMax 3,5 m
611150 L : 3 m, LMax 4,5 m

PLASTIQUE - PLASTICA - PLÁSTICA



D14312 LMax 3,5 m
611070 L : 3 m, LMax 4,5 m



D14316 LMax 3,5 m
611080 L : 3 m, LMax 4,5 m

EURO6

D14574 L : 3 m, LMax 4,5 m

D14575 L : 3 m, LMax 4,5 m

EURO6

6 x 1,0 mm² + 1 x 1,5 mm²



611110 24N/24S

24N

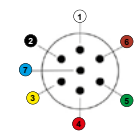

- ① - Masse
- ② - Feu de position G
- ③ - Clignotant G
- ④ - Feu Stop
- ⑤ - Clignotant D
- ⑥ - Feu de position D,
- ⑦ - Commande de frein

- Common return
- L rear position lamp
- L flasher lamp
- Stop lamp
- R flasher lamp
- R rear position lamp,
- Breaking control

- Masse
- Linke Schlussleuchte
- Fahrlichtungsanzeiger links
- Bremsleuchte
- Fahrlichtungsanzeiger rechts
- Rechte Schlussleuchte
- Steuerung Anhängerbremse

24S

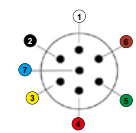

- ① - Masse
- ② - Sans affectation
- ③ - Feu de recul
- ④ - Alimentation en puissance
- ⑤ - Sans affectation
- ⑥ - Sans affectation
- ⑦ - Feu AR de brouillard

- Common return
- Without affectation
- Reverse lamp
- Power supply
- Without affectation
- Without affectation
- Fog lamp

- Masse
- Nicht belegt
- Rückfahrleuchte
- Stromversorgung (Dauerplus)
- Nicht belegt
- Nicht belegt
- Nebelschlussleuchte

Prises et câbles spiralés - Spine e spirali - Enchufes y espirales

15P



24V

ISO 12098



A10060



A10061



D14315 LMax 3,5 m

D11578 L : 3 m, LMax 4,5 m

D14577 L : 3 m, LMax 4,5 m **EURO6**

7P-15P



24V



D11487 L : 3 m, LMax 4,5 m

D14824 LMax 3,5 m



D14689 L : 3 m, LMax 4,5 m

EURO6 **D14578** L : 3 m, LMax 4,5 m

D14802 LMax 3,5 m



D13889



A10064

ABS/EBS



ISO 7638-1



611560 ABS/EBS



A10062 ABS/EBS



A10065 ABS/EBS



A10066 ABS/EBS



D14311 LMax 3,5 m ABS/EBS 5P

D10597 L : 3 m, LMax 4,5 m ABS/EBS 7P

D14576 L : 3 m, LMax 4,5 m ABS/EBS 7P **EURO6**



611570 PARC ABS/EBS-15P

ABS/EBS



- | | | |
|---|--------------------|--------------------|
| ⊕ - Plus (+) alimentation électrovanne | Plus electrovalve | Plus Magnetventil |
| ⊕ - Plus (+) connexions électroniques | Plus electronics | Plus Elektronik |
| ⊖ - Moins (-) connexions électroniques | Minus electronics | Minus Elektronik |
| ⊖ - Moins (-) alimentation électrovanne | Minus electrovalve | Minus Magnetventil |
| ⊙ - Connexion lampe témoin | Warning device | Warneinrichtung |
| Ⓜ - Connexion donnée CANH | CANH | Datenleitung CANH |
| Ⓝ - Connexion donnée CANL | CANL | Datenleitung CANL |

15 PÔLES



- | | | |
|--------------------------------------|----------------------------|---|
| ① - Clignotant gauche | L flasher lamp | Fahrtrichtungsanzeiger links |
| ② - Clignotant droit | R flasher lamp | Fahrtrichtungsanzeiger rechts |
| ③ - Feu AR de brouillard | Fog lamp | Nebelschlussleuchte |
| ④ - Masse | Common return | Masse |
| ⑤ - Feu de position gauche | L rear position lamp | Linke Schlussleuchte |
| ⑥ - Feu de position droit | R rear position lamp | Rechte Schlussleuchte |
| ⑦ - Feu stop | Stop lamp | Bremsleuchte |
| ⑧ - Feu de recul | Reverse lamp | Rückfahrleuchte |
| ⑨ - Alimentation 24V | 24V power supply | Stromversorgung +24V |
| Ⓜ - Capteur d'usure des freins | Worn brake indicator | Sensor für Bremsbelagverschleissanzeige |
| ⑪ - Capteurs de pressions des freins | Brake pressure collector | Anzeige für Federspeicherbremse |
| ⑫ - Dispositif de levage d'essieu | Adjustable suspension lift | Achsanhebung |
| ⑬ - Masse pour contacts 14 et 15 | Common return | Masse für Datenleitungen |
| ⑭ - Bus de données | Data line | Datenleitung |
| ⑮ - Bus de données | Data line | Datenleitung |

USBA.RBL



12/24V

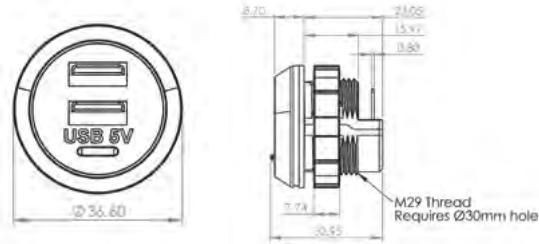

NEW



D16007

NEW



D16100

USBA.3.APL



12/24V

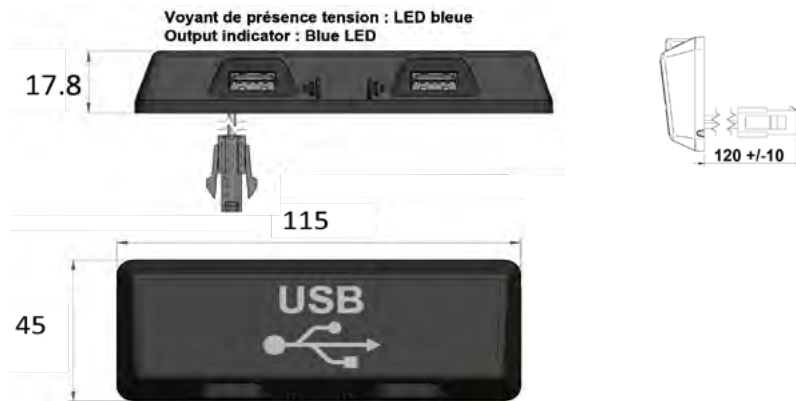

NEW



D16099



Connecteurs

Connettori

Conectores



Flashez le QR code pour plus d'infos
Scansiona il codice QR per maggiori informazioni
Escanee el código QR para obtener más info

AMP 1.5-7P-M

Type connecteur - Nb pins - Mâle ou Femelle
Tipo di connettore - Num pin - Maschio o Femmina
Tipo de conector - Num pines - macho o hembra

AMP 1.5



D11868

AMP 1.5-7P-F

Connecteur AMP 1.5 simple femelle
Connettore AMP 1.5 singolo femmina
Conector AMP 1.5 simple hembra

Pour / Per / Para
LC5, LC7, LC8, LC9, LC12, LC11, LC10



NEW



D11809

AMP 1.5-7P-M

Connecteur AMP 1.5 simple mâle
Connettore AMP 1.5 singolo maschio
Conector AMP 1.5 simple macho

HDSCS



D13878

HDSCS-8P-F

Connecteur HDSCS simple
Connettore HDSCS singolo
Conector HDSCS simple

Pour / Per / Para
LC8



AMP MCP



NEW



D14984

AMP-MCP-4P-F

Connecteur AMP MCP simple
Connettore AMP MCP singolo
Conector AMP MCP simple

Pour / Per / Para
LCR19



JPT



D13876

JPT-2P-F

Connecteur JPT 2 voies
Connettore JPT 2 vie
Conector JPT 2 vías

Pour / Per / Para
EPP98, SMD98,
FPL93, FE98



D13877

JPT-3P-F

Connecteur JPT 3 voies
Connettore JPT 3 vie
Conector JPT 3 vías

Pour / Per / Para
ICDL94



SUPERSEAL



D13880

SS-2P-F

Connecteur SUPERSEAL 2 voies femelle
Connettore SUPERSEAL 2 vie femina
Conector SUPERSEAL 2 vías hembra

Pour / Per / Para
SMD98, FPL93, LC12, ICDL10,
LPL18



D14208

SS-2P-M

Connecteur SUPERSEAL 2 voies mâle
Connettore SUPERSEAL 2 vie maschio
Conector SUPERSEAL 2 vías macho



D14362

SS-3P-F

Connecteur SUPERSEAL 3 voies femelle
Connettore SUPERSEAL 3 vie femina
Conector SUPERSEAL 3 vías hembra

Pour / Per / Para
SMCU



D14331

SS-3P-M

Connecteur SUPERSEAL 3 voies mâle
Connettore SUPERSEAL 3 vie maschio
Conector SUPERSEAL 3 vías macho

POS



D13879

POS-2P-F

Connecteur 2 voies position femelle
Connettore 2 vie femina
Conector 2 vías hembra

Pour / Per / Para
LC8T, DX



D14214

POS-2P-M

Connecteur 2 voies position mâle
Connettore 2 vie maschio
Conector 2 vías macho



D14170

DT-2P-F

connecteur 2 voies DT femelle
connettore 2 vie DT femmina
conector 2 vías DT hembra

Pour / Per / Para
Feux de travail, Fari di lavoro,
Faros de trabajo



NEW



D15155

DT-2P-M

connecteur 2 voies DT male
connettore 2 vie DT maschio
conector 2 vías DT macho

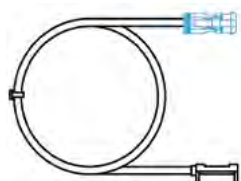

R12486

1500 mm

câble adaptateur DT 2V-CLICK-IN
cavo adattatore DT 2V-CLICK-IN
cable adaptador DT 2V-CLICK-IN

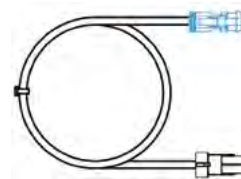

R14413

1500 mm

câble adaptateur DT-SUPERSEAL
cavo adattatore DT-SUPERSEAL
cable adaptador DT-SUPERSEAL



D14436

DT06-4S-4P-F

connecteur 4 voies DT06-4S femelle
connettore 4 vie DT06-4S femmina
conector 4 vías DT06-4S hembra

Pour / Per / Para
CTL15, BL15



D14434

DT04-4P-M

connecteur 4 voies DT04-4P mâle
connettore 4 vie DT04-4P maschio
conector 4 vías DT04-4P macho



D14437

DTM06-4S-4P-F

connecteur 4 voies DTM06-4S femelle
connettore 4 vie DTM06-4S femmina
conector 4 vías DTM06-4S hembra

Pour / Per / Para
CTL15, BL15



D14435

DTM04-4P-M

connecteur 4 voies DTM04-4P mâle
connettore 4 vie DTM04-4P maschio
conector 4 vías DTM04-4P macho



D14352

DT-6P-M

connecteur 6 voies DT
connettore 6 vie DT
conector 6 vías DT

Pour / Per / Para
CHL



Faisceaux Cablaggi Cableados

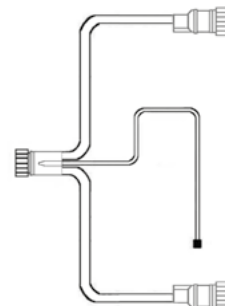

Flashez le QR code pour plus d'infos
Scansiona il codice QR per maggiori informazioni
Escanee el código QR para obtener más info

AMP 1.5-7P-M

Type connecteur - Nb pins - Mâle ou Femelle
Tipo di connettore - Num pin - Maschio o Femmina
Tipo de conector - Num pines - macho o hembra

ADP RSC



ADR



24N 24S / 15P

ADAPTATEURS AVANT - PRESE ANTERIORE - ENCHUFES DELANTEROS

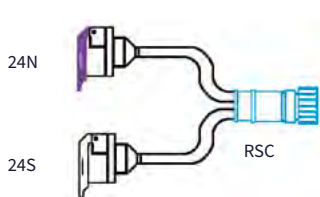

D10504 1000 mm 16V

D13257 1500 mm 15V

Faisceau prises 24N / 24S
Cavo con connettore 24N / 24S
Cable con enchufes 24N / 24S

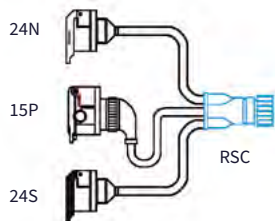

D14780 500 mm 16V

D13256 300 mm 15V

Faisceau prises 15P / 24N / 24S
Cavo con connettore 15P / 24N / 24S
Cable con enchufes 15P / 24N / 24S

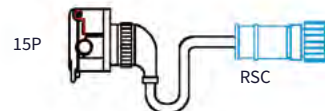

D13254 1000 mm 16V

D13255 600 mm 15V

Faisceau prises 15P
Cavo con connettore 15P
Cable con enchufes 15P

Comment différencier rapidement les connecteurs RSC ? Come distinguere i connettori RSC? ¿Cómo distinguir los conectores RSC?

Un connecteur RSC 16 voies présente 4 pins centraux alors qu'un connecteur RSC 15 voies en présente 3 (voir schéma ci-contre).

Un connettore RSC 16 vie presente 4 pins nel centro, mentre un connettore RSC 15 vie ne presente solo 3 (vedere disegno allegato).

Un conector RSC 16 polos tiene 4 pins en el centro mientras que un conector RSC 15 polos tiene 3 pins (esquema).

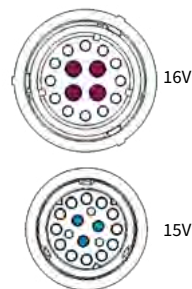

PRL RSC



ADR

CÂBLE D'ALIMENTATION PRINCIPALE - CAVO DI ALIMENTAZIONE PRINCIPALE - MANGUERA DE ALIMENTACIÓN PRINCIPAL



D10505 16 m 16V

D13263 15 m 15V

Prolongateur RSC simple
Prolunga RSC semplice
Manguera alargadora RSC simple

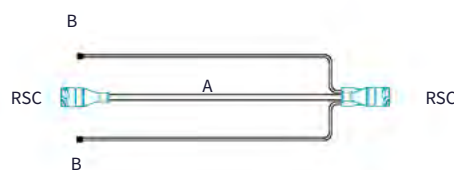

D10510 A: 10 m / B: 10 m 16V

D10508 A: 16 m / B: 16 m 16V

D13260 A: 15 m / B: 0,27 m* 15V

Prolongateur avec câbles plats
Prolunga RSC con cavi piatti
Manuera alargadora RSC con cables planos
* avec autoproforants / con click-in

FCA RSC



ADR

ADAPTATEURS ARRIÈRE - PRESE OSTERIORE - ENCHUFES TRASEROS

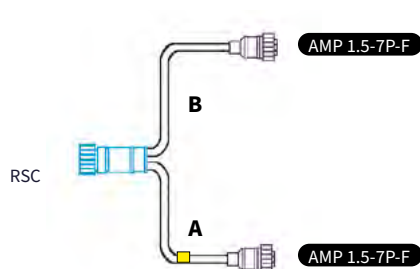

D10513 A: 3,5 m / B: 3,5 m 16V

Faisceau pour feux arrière avec surmoulages droits
Cavo per fanali posteriori con connettore pressofuso dritto
Manguera para pilotos traseros con conector sobremoldeado rectos
■ = gauche - sinistra - derecha

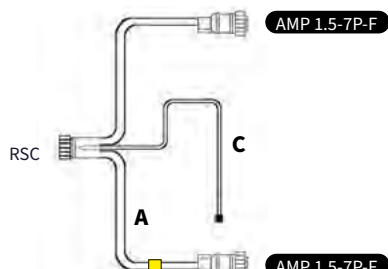

D13262 A: 2,5 m / B: 1,5 m / C: 1,2 m 15V

Faisceau pour feux arrière avec câbles plats et surmoulages droits
Cavo per fanali posteriori con cavi piatti e connettori pressofuso dritto
Manguera para pilotos traseros con cables planos y conectores sobremoldeado rectos
■ = gauche - sinistra - derecha

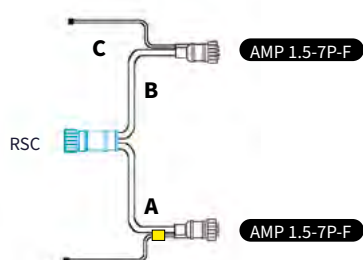

D10514 A/B: 2 m / C: 0,5 m 16V

D10515 A: 1,5 m / B: 2,5 m / C: 16 m 16V

R12499 A: 2,5 m / B: 1,5 m / C: 0,5 m 15V

Faisceau pour feux arrière avec câbles plats et surmoulages droits
Cavo per fanali posteriori con connettore pressofuso dritto
Manguera para pilotos traseros con conector sobremoldeado rectos
■ = gauche - sinistra - derecha

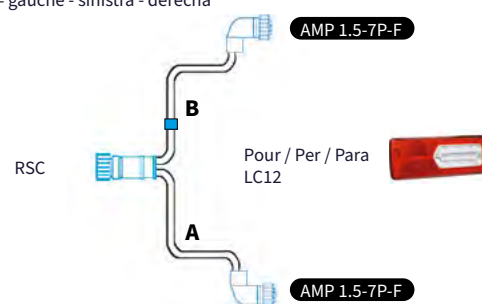

R14407 A: 2 m / B: 2 m 16V

Faisceau pour feux arrière LC12T avec surmoulages coulés
Cavo per fanali posteriori LC12T con connettore 90°
Manguera para pilotos traseros LC12 con conector sobremoldeado 90°
■ = gauche - sinistra - derecha

MDJ



ADR

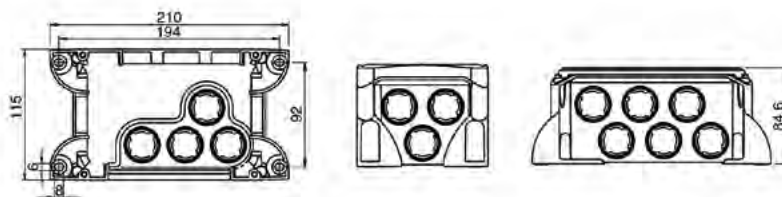

SYSTÈME MDJ - SISTEMA SCATOLA DI DERIVAZIONE - SISTEMA CAJA



175020



D11889



175086 cable Ø 5,9-6,9

177136 cable Ø 8,3-10

175096 cable Ø 11-12

Faisceaux - Cablaggi - Cableados

FCA

Pour feux arrière type LCR19 p.114

Per fanali posteriori LCR19 p.114

Para pilotos traseros LCR19 p.114



D14984

AMP-MCP-4P-F

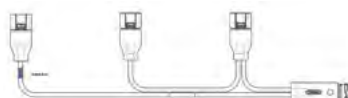

D14980

AMP 1.5-7P-M



D14983

AMP-MCP-4P-F



Affectations constructeurs
Applicazione primo impianto
Afectación primer equipo

SCHMITZ p. 93



AMP-MCP-4P-F

D14846

HDSCS-6P-F

gauche - sinistra - izquierda



AMP-MCP-4P-F

D14847

HDSCS-6P-F

droit - destra - derecha

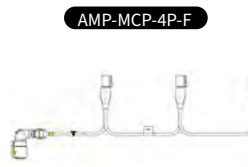

AMP-MCP-4P-F

D14884

HDSCS-6P-F

gauche - sinistra - izquierda

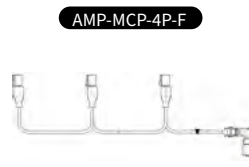

AMP-MCP-4P-F

D14885

HDSCS-6P-F

droit - destra - derecha

COVER



CAPOT DE PROTECTION - PROTEZIONE - PROTECCIÓN

175 mm x 68 mm x 52 mm

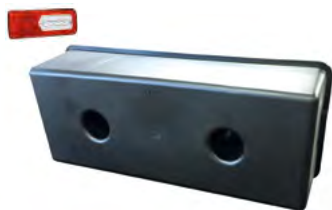

D14721

Capot de protection pour connectiques LC12
Protezione per connettori LC12
Protección para conectores LC12

195 mm x 70 mm x 113 mm



D13726

Capot de protection pour connectique
coudée feu arrière
Protezione per fanali posteriori con
connettori 90°
Protección para piloto trasero con conector
90°

195 mm x 70 mm x 113 mm



D13725

Capot de protection pour connectique
droite feu arrière
Protezione per fanali posteriori con
connettori dritto
Protección para piloto trasero con conector
recto

KIT



KITS DE RÉPARATION POUR FEUX ARRIÈRE - KIT DI REPARAZIONE PER FANALI POSTERIORI - KIT DE REPARACIÓN PARA PILOTOS TRASEROS



D11868

AMP 1.5-7P-F

Connecteur AMP 1.5 simple
Connettore AMP 1.5 singolo
Conector AMP 1.5 simple



D11865

500 mm

Connecteur AMP 1.5 avec câble plat
Connettore AMP 1.5 con cavo piatto
Conector AMP 1.5 con manguera plana

NEW



D11809

AMP 1.5-7P-M

Connecteur AMP 1.5 simple mâle
Connettore AMP 1.5 singolo maschio
Conector AMP 1.5 simple macho



CÂBLES FEUX ARRIÈRE - CAVI PER FANALI POSTERIORI - CABLES PARA PILOTOS TRASEROS



AMP 1.5

Pour feux arrière type LC5, LC6, LC7, LC8, LC9, LC12 p.112

Per fanali posteriori LC5, LC6, LC7, LC8, LC9, LC12 p.112

Para pilotos traseros LC5, LC6, LC7, LC8, LC9, LC12 p.112



AMP 1.5-7P-F

D11626 2500 mm

D11627 4300 mm

Pour module de jonction 175020
Per scatola di derivazione 175020
Para caja de derivación 175020



AMP 1.5-7P-F

D11628 2500 mm

Fils nus
Estremità cavo nuda
Cable pelado

AMP 1.5

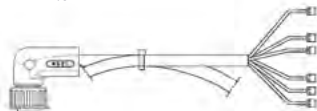

AMP 1.5-7P-F

280049 4000 mm

Fils nus
Estremità cavo nuda
Cable pelado

RALLONGES - PROLUNGA - ALARGADORES



AMP 1.5-7P-M

AMP 1.5-7P-F

D12449 1000 mm

D12450 2000 mm

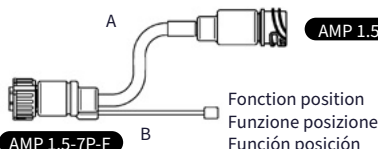

AMP 1.5-7P-M

AMP 1.5-7P-F

R12575 A: 3 m / B: 3 m

R12576* A: 0,5 m / B: 3 m

* Pour / Per / Para LC9 p. 135



DOUBLEUR DE FEUX - CAVO PER DOPPI FANALI POSTERIORI - MANGUERA PARA DOBLES PILOTOS TRASEROS



AMP 1.5-7P-F

AMP 1.5-7P-M

D11689 500 mm





CÂBLES FEUX LATÉRAUX - CAVO LUCI DI POSIZIONE - CABLES PARA PILOTOS DE POSICIÓN AMP JPT

ADR



AMP JPT

Pour éclairateurs de plaque EPP98 p. 152 et feux de position SMD98, FE98 et FPL93 p. 161

Per luce targa EPP98 p. 152 e luce di posizione SMD98, FE98 e FPL93 p. 161

Para piloto iluminación de placa EPP98 p. 152 y piloto de posición SMD98, FE98 y FPL93 p. 161



JPT-2P-F

280009	A : 2 m
280019	A : 4 m
280029	A : 6 m

Fils nus
Estremità cavo nuda
Cable pelado

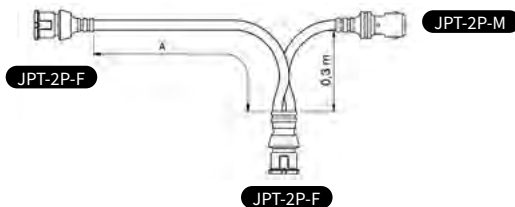

280059	A : 3,5 m
---------------	-----------

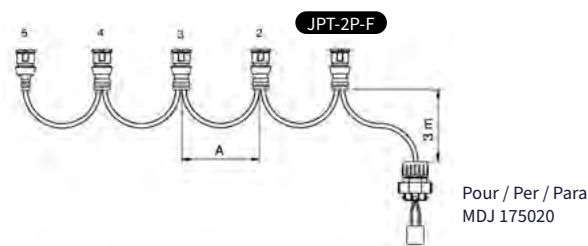

4 x JPT	280099	A : 3,5 m	280139	A : 5,5 m
5 x JPT	280109	A : 3,5 m	280149	A : 5,5 m

KIT

KITS DE RÉPARATION POUR FEUX LATÉRAUX - KIT DI REPARAZIONE PER LUCI LATERALI - KIT DE REPARACIÓN PARA PILOTOS LATERALES

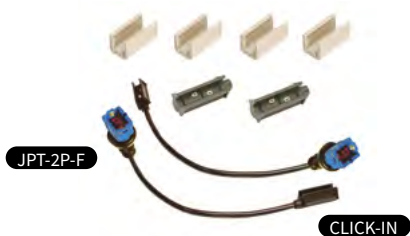

001796	500 mm
001806	1500 mm



001786	500 mm
---------------	--------



D13876	JPT-2P-F
---------------	----------

Connecteur JPT 2 voies
Connettore JPT 2 vie
Conector JPT 2 vías

FCA



ADR



SUPERSEAL

Pour éclairateurs de plaque LPL18, EPP96LED p. 269 et feux de position SMD98, DX p. 269

Per luce targa LPL18, EPP96LED p. 269 e luce di posizione SMD98, DX p. 269

Para piloto iluminación de placa LPL18, EPP96LED p. 269 y piloto de posición SMD98, DX p. 269



CÂBLES FEUX LATÉRAUX - CAVO LUCI DI POSIZIONE - CABLES PARA PILOTOS DE POSICIÓN SUPERSEAL

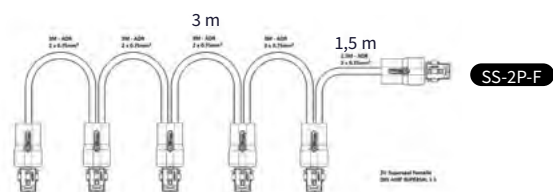

R14173 17,5 m

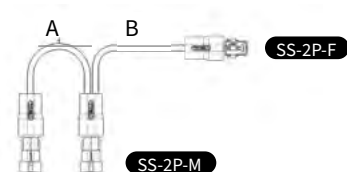

R14418 A : 300 mm/ B:500 mm



R14426 1500 mm

Rallonge SUPERSEAL 2 voies
Prolunga SUPERSEAL 2 vie
Alargador SUPERSEAL 2 vías



D14985 1500 mm

KIT



KITS DE RÉPARATION POUR FEUX LATÉRAUX - KIT DI REPARAZIONE PER LUCI LATERALI - KIT DE REPARACIÓN PARA PILOTOS LATERALES



D13880

SS-2P-F

Connecteur SUPERSEAL 2 voies femelle
Connettore SUPERSEAL 2 vie femmina
Conector SUPERSEAL 2 vías hembra

Pour / Per / Para
SMD98, FPL93, LC12, ICDL10,
LPL18



D14208

SS-2P-M

Connecteur SUPERSEAL 2 voies mâle
Connettore SUPERSEAL 2 vie maschio
Conector SUPERSEAL 2 vías macho



Câble plat
Cavo piatto
Manguera plana



D11268 16 m

A10779 100 m

Câble plat - Cavo piatto - cable plano



D11147 500 mm

Câble plat optionnel avec connecteur 2 voies pour repiquage sur feu arrière LC8
Cavo piatto opzionale con connettore a 2 vie per collegamento su fanale posteriore LC8
Manguera plana opcional con conector 2 vías para acoplamiento con piloto trasero LC8

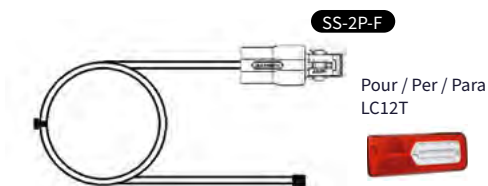

R14412 16 m

Câble plat optionnel avec connecteur 2 voies SUPERSEAL pour repiquage sur feu arrière LC12T
Cavo piatto opzionale con connettore a 2 vie SUPERSEAL per collegamento su fanale posteriore LC12T
Manguera plana opcional con conector 2 vías SUPERSEAL para acoplamiento con piloto trasero LC12T

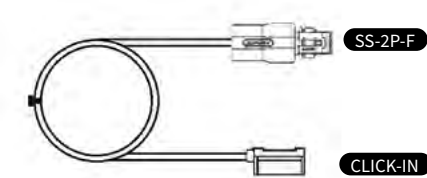

R14416 1500 mm

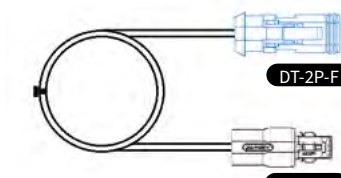

R14413 1500 mm



R14339 7,5 m
4V DT



R14338 8,5 m
4V DT

ACC



D10517 500 mm

D10518 1500 mm

D10519 3500 mm



D10132 200 mm



151236

Verrou pour click-in à usage unique
 Morsetto click-in per uso unico
 Abrazadera para click-in con uso único

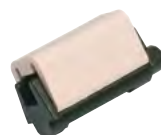

001826

Obtuteur seal-in
 Protezione per seal-in
 Protección para seal-in

Systemes câblage et feux

Kit cablaggi e fanali

Sistemas cableados y iluminación

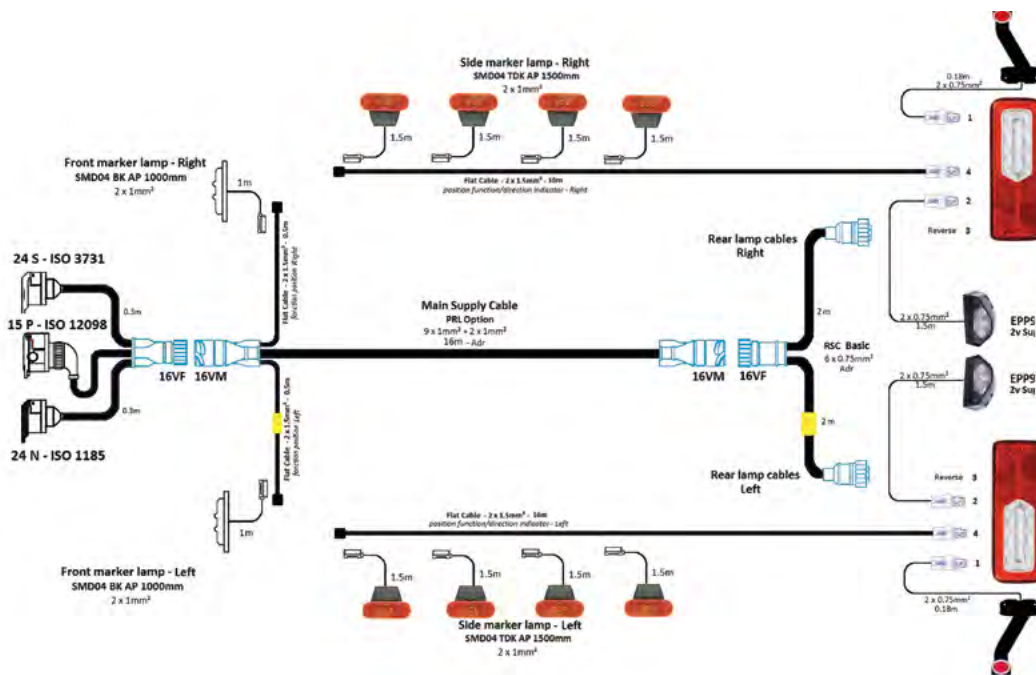

Flashez le QR code pour plus d'infos
Scansiona il codice QR per maggiori informazioni
Escanea el código QR para obtener más info

AMP 1.5-7P-M

Type connecteur - Nb pins - Mâle ou Femelle
Tipo di connettore - Num pin - Maschio o Femmina
Tipo de conector - Num pines - macho o hembra

KITS COMPLETS LED - KIT COMPLETO LED - KITS COMPLETOS LED



FEUX DE POSITION LATÉRAUX LED CLIGNOTANTS gestion selon supplément 6 - R48
 LUCI LATERALI LED LAMPEGGIANTI gestione secondo supplemento 6 - R48
 PILOTOS DE POSICION LED INTERMITENTES según suplemento 6 - R48



24V

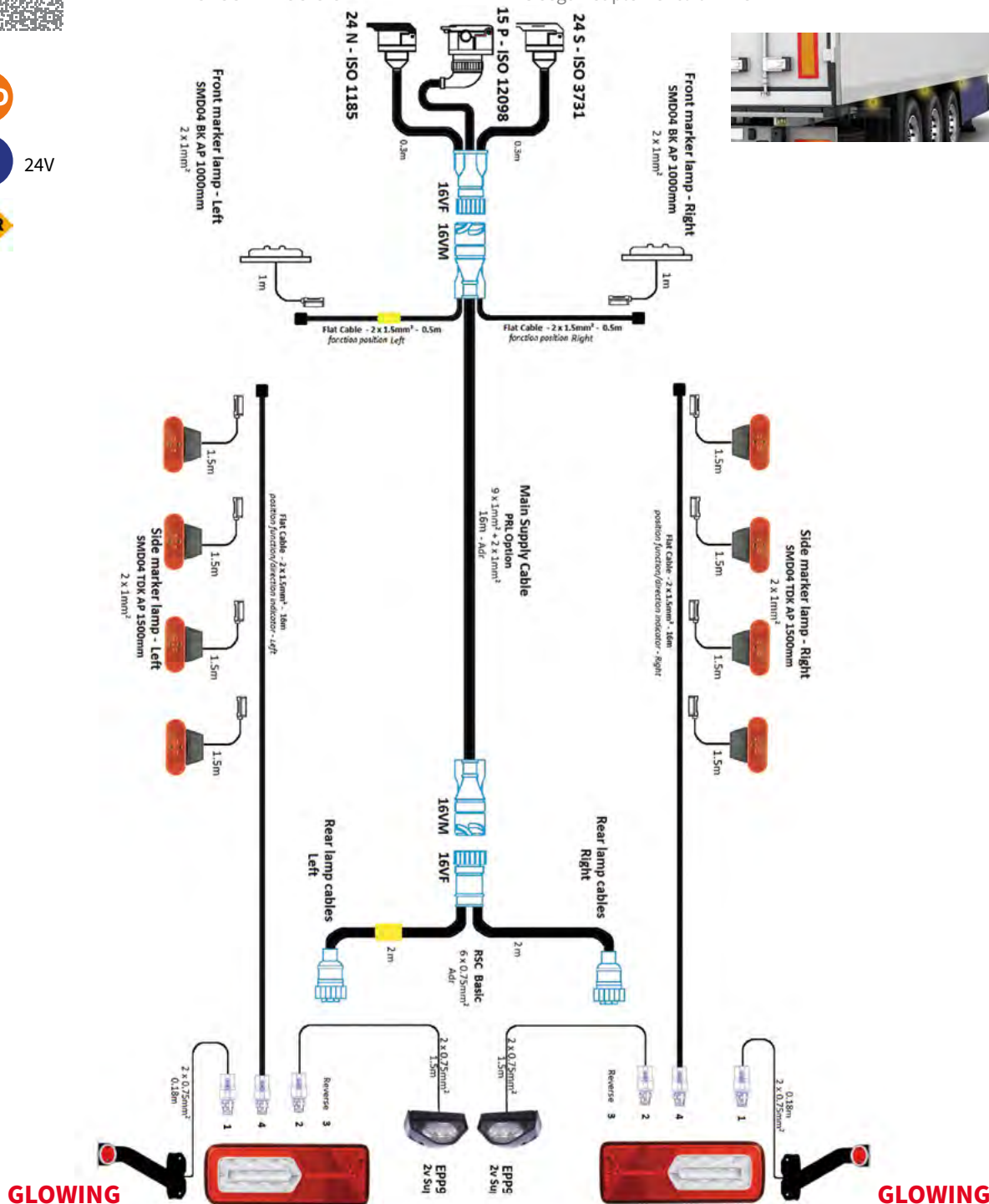

A14366

Kit complet 100% LED : 2 feux arrière LC12TLED, 2 feux sur antennes DX led câbles SS 1,5 m, 2 Eclairers de plaque EPP96 LED câble ADR SS 1,5 m, 8 feux de position latéraux clignotants LED SMD04 câble AP 1500 mm, 2 feux de position avant LED SMD04 câble AP 1000 mm.

Câblage système RSC de 16 m avec câbles plats latéraux de 16 m connectique SS, câble adaptateur arrière de 2 m, adaptateur avant 3 prises.

Kit completo 100% LED: 2 fanali posteriori LC12TLED, 2 cornetti LED con cavo SS 1,5m, 2 luce targa LED con cavo ADR SS 1,5m, 8 fanali laterali lampeggianti LED SMD04 con cavo 1500mm, 2 fanali d'incombro anteriori LED SMD04 con cavo AP 1000mm.

Cablaggio sistema RSC 16m con cavi piatti laterali connettori SS, cavo per fanali posteriori 2 m, adattatore 3 prese anteriore, Equipaggiamento di compatibilità universale

Kit completo 100% LED: 2 pilotos traseros LC12TLED, 2 pilotos de anchura DX LED cables SS 1,5 m, 2 luces de matrícula EPP96 LED cable SS 1,5m, 8 pilotos de posición laterales intermitentes LED SMD04 cable click-in 1500 mm, 2 pilotos de posición delanteros LED SMD04 cable click-in 1000 mm. Cableado sistema RSC de 16 m con cables planos laterales de 16 m conector SS, cable para pilotos traseros de 2 m, adaptador delantero 3 enchufes.

KITS COMPLETS - KIT COMPLETO - KITS COMPLETOS



24V

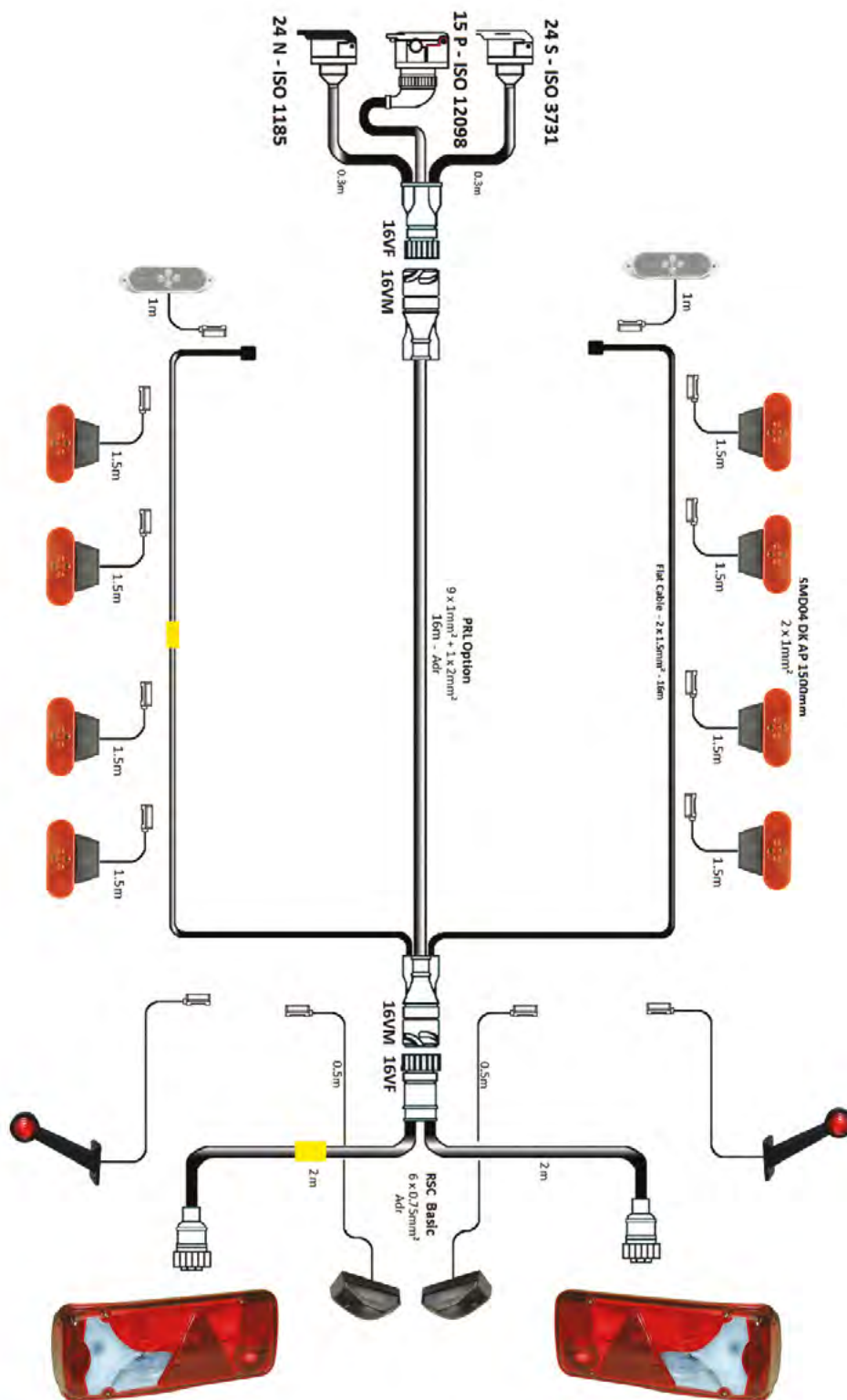

A11212

Kit complet : 2 feux arrière LC8T, 2 feux sur antennes DX câbles AP 600mm, 2 Eclairieurs de plaque EPP96 câble ADR AP 410 mm, 8 feux de position latéraux LED SMD04 bride soudée câble AP 1500 mm, 2 feux de position avant LED SMD04 câble AP 1000 mm.

Câblage système RSC de 16 m avec câbles plats latéraux de 16 m, câble adaptateur arrière de 2 m, adaptateur avant 3 prises

Kit completo : 2 fanali posteriori LC8T, 2 cornetti con cavo AP 600mm, 2 luce targa con cavo ADR AP 410mm, 8 fanali laterali LED SMD04 con braccio 90° con cavo 1500mm, 2 fanali d'incombro anteriori LED SMD04 con cavo AP 1000mm.

Cablaggio sistema RSC 16m con cavi piatti laterale, cavo per fanali posteriori 2 m, adattatore 3 prese anteriore

Kit completo : 2 pilotos traseros LC8T, 2 pilotos de anchura DX cables click-in 600mm, 2 luces de matrícula EPP96 cable ADR click-in 410 mm, 8 pilotos de posición laterales LED SMD04 soporte 90° cable click-in 1500 mm, 2 pilotos de posición delanteros LED SMD04 cable click-in 1000 mm. Cableado sistema RSC de 16 m con cables planos laterales de 16 m, cable para pilotos traseros de 2 m, adaptador delantero 3 enchufes

KITS COMPLETS LED - KIT COMPLETO LED - KITS COMPLETOS LED

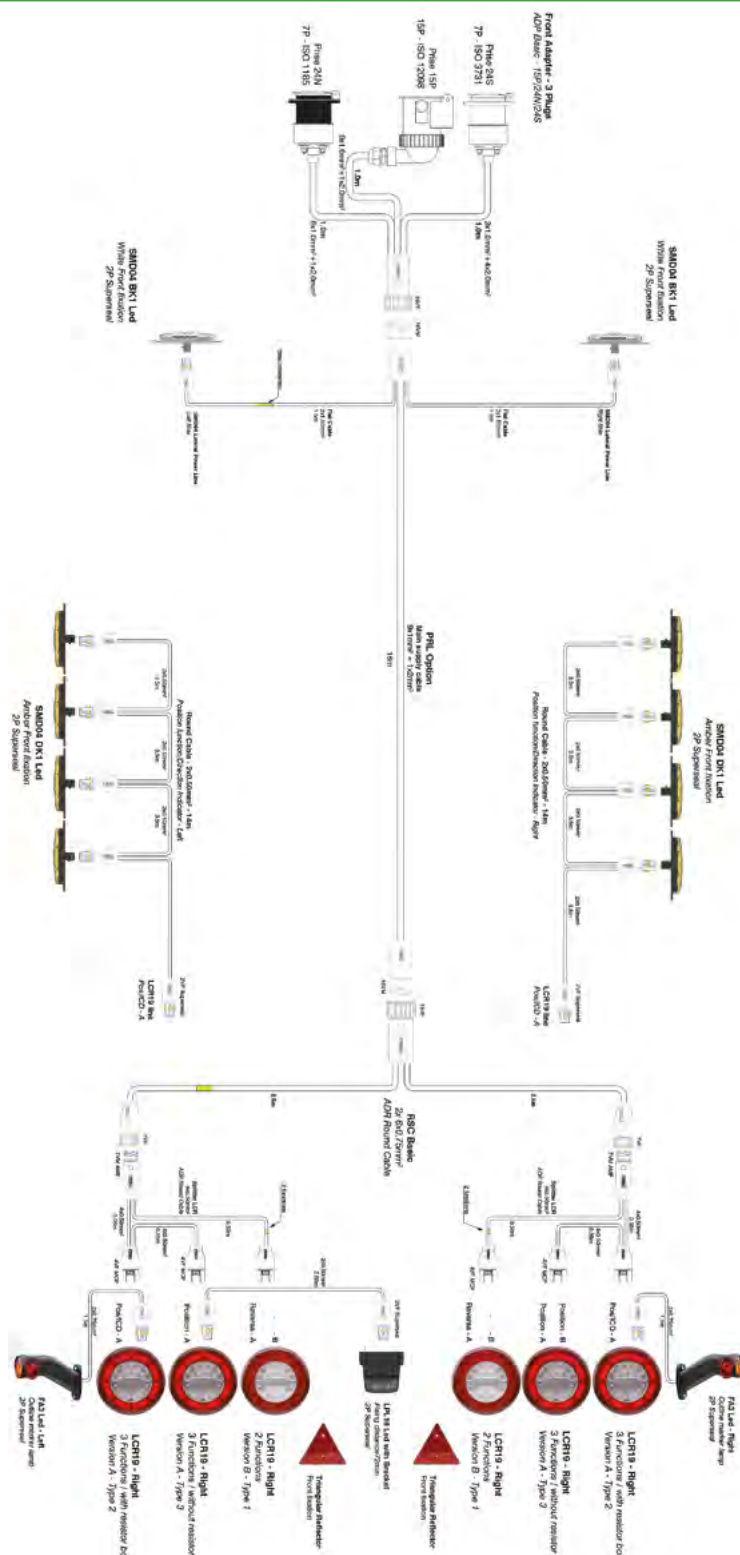

NEW

A15153

Kit complet 100% LED : 2 feux arrière LCR19 3 fonctions avec résistance, 2 feux arrière LCR19 3 fonctions sans résistance, 2 feux arrière LCR19 2 fonctions, 2 feux sur antennes FA3 led câbles SS 1,5 m, 1 Eclairer de plaque LPL18 câble ADR SS 2,5 m, 8 feux de position latéraux clignotants LED SMD04 SS, 2 feux de position avant LED SMD04 SS. Câblage système RSC de 16 m avec câbles plats latéraux de 16 m connectique SS, câble adaptateur arrière de 2,5 m, adaptateur avant 3 prises.

Kit completo 100% LED: 2 fanali posteriori LCR19 3 funzioni con scatola di resistenza, 2 fanali posteriori LCR19 3 funzioni senza scatola di resistenza, 2 fanali posteriori LCR19 2 funzioni, 2 cornetti LED con cavo SS 1,5m, 1 luci targa LED con cavo ADR SS 2,5 m, 8 fanali laterali lampeggianti LED SMD04 SS, 2 fanali d'incontro anteriori LED SMD04 SS. Cablaggio sistema RSC 16m con cavi piatti laterali connettori SS, cavo per fanali posteriori 2,5 m, adattatore 3 prese anteriore, Equipaggiamento di compatibilità universale

Kit completo 100% LED: 2 pilotos traseros LCR19 3 funciones con caja de resistencia, 2 pilotos traseros LCR19 3 funciones sin caja de resistencia, 2 pilotos traseros LCR19 2 funciones, 2 pilotos de anchura DX LED cables SS 1,5 m, 1 luz de matrícula LPL18 cable SS 2,5m, 8 pilotos de posición laterales intermitentes LED SMD04 SS, 2 pilotos de posición delanteros LED SMD04 SS. Cableado sistema RSC de 16 m con cables planos laterales de 16 m conector SS, cable para pilotos traseros de 2,5 m, adaptador delantero 3 enchufes.

Index : Liste de correspondance - Codici costruttore - Referencias cruzadas

	OES	VIGNAL		OES	VIGNAL
DAF	0867930	196010	IVECO	500356783	D11482
	1272653	067500		504097923	193290
	1284211	167640		580224029	160120
	1284212	167630		5801363428	169390
	1304788	168010		5801363430	169400
	1304789	168020		5801363431	169410
	1329718	193020		5801363432	169420
	1401713	152170		5801426889	153220
	1401731	152180		5801426894	153210
	1403887	195010		5801426912	153200
	1451482	052500		5801426917	153230
	1519368	D12953		5801426975	153240
	1608352	001726		5801426977	153250
	1625985	169160		5801426979	153260
	1625986	169170		5801572018	110560
	1626101	119550		5801572024	110550
	1626102	001616		5801631615	198760
	1653605	193200		5801637182	155480
	1660967	168890		5801637199	155450
	1660968	169380		5801637201	155460
	1846491	117000		5801637202	155470
	1846492	117010		5801757326	155500
	1875576	155110		5801757328	155490
	1875577	155100		5802000568	160080
	1875578	155120		5802000570	160110
	1875579	155140		5802000573	160100
	1875580	155130		5802000767	160090
	1875581	155150		5802000770	160130
	1914690	055020		5802000772	160120
	1914691	055030		5802055272	155540
	1973239	001830		5802055273	160140
	1626319/1284213	168100		5802062689	160150
	1626320/1284214	168390		5802240291	160150
	1814096/1815754	109010		5802240292	160080
				5802240293	160110
FIAT	1305797	193170		5802240294	160140
	71749250	193360		5802240295	160100
	1356794080	193360		5802240296	160090
	1372698080	153280		5802240297	160130
	1372699080	153270		5802830033 EZ	154200
				5802830034 EZ	154210
FORD	1940131	D16109		5802980630 EZ	154220
	1940132	D16108		5802980631 EZ	154220
				5802984152 EZ	053730
IVECO	791123	152180		A610067-002	052500
	1608352	001726		R504083205	168480
	41200664	193170	LECAPITAINE	661012	D11689
	41221040	119930		661058	164050
	41221041	119920			
	42535711	052500	MAN	7CE945095	155550
	42555041	110530		7CE945096	155560
	42555042	110520		81.25225-6544	156200
	42555131	D12337		81.25225-6545	156210
	42555132	D12336		81.25225-6547	156220
	42566495	052500		81.25229-6059	056500
	47363002	199000		81.25229-6060	056510
	69500026	D12335		81.25207-6074	212020
	69500032	D12334		81.25207-6075	212030
	69500044	D12341		81.25103-6076	D16110
	69500047	D12340		81.25225-6526	169180
	69500590	D12339		81.25225-6523	169170
	69500591	D12338		81.25225-6524	169160
	93161844	067500		81.25225-6530	169190
	99463244	168610		81.25225-6033/6464	168090
	500308514	193020		81.25225-6034	168100
	500356782	D11481			

Index : Liste de correspondance - Codici costruttore - Referencias cruzadas

	OES	VIGNAL		OES	VIGNAL
MAN	81.25225-6528	168490	RENAULT TRUCKS	5001846846	152050
	81.25229-6051	067500		5001846847	152020
MERCEDES	A 000 826 20 56	056540	5001846848	152030	
	A 000 826 21 56	056550	5001846849	152060	
	A 405 820 0158	212420	5001846850	152070	
	A 906 820 04 64	156340	5001847153	052500	
	A 906 820 17 64	156350	5001847582	169060	
	A 910 206 29 00	212010	5001847583	169070	
	A 910 820 64 00	160400	5001847584	169000	
	A 910 820 65 00	160410	5001847585	169010	
	A 910 826 10 00	060000	5001847586	169020	
	A 910 826 11 00	060010	5001847587	169030	
	A 910 906 36 00	212010	5001847588	067500	
	A 910 906 69 00	212420	5001847589	001726	
	A 910 906 6900	212420	5001847597	119470	
	A 949 540 01 04	196170	5001857964	152510	
	A 956 544 00 11	1987860	5001857965	152520	
	A 956 820 00 59	116200	5001858092	152500	
	A 956 820 02 58	212710	5001858093	152600	
	A 959 544 01 03	155590	5001862030	102200	
	A 959 544 02 03	155600	5001862030	193200	
	A 959 544 03 03	155610	5001864535	169310	
A 960 820 0258	212710	5001864536	169320		
A 960 820 0358	212710	5001870556	152180		
NISSAN	26164-9X402	119550	5010217022	185020	
	26244-9X400	001616	5010217023	185040	
	26554-9X126	052500	5010271807	185160	
	26555-9X125	152180	5010293829	196010	
	26555-9X126	152170	5010306792	193020	
	26555-9X128	153120	5010392231	052000	
			5010595381	152170	
OPEL	4421269	196010	5010595382	152180	
	4421265/6	152180	7420802348	159010	
PEUGEOT CITROËN	9815126980	153280	7420802350	159020	
	9815127080	153270	7420802353	159030	
	63501FS	153280	7420802418	059000	
	6350FS	153270	7420862032	152880	
RENAULT TRUCKS	23811106	212740	7420862035	152880	
	23811107	212750	7420862038	152190	
	5000296591	166000	7420862041	152200	
	5000296591	166100	7420894265	193280	
	5000296592	167000	7421106206	198650	
	5000296592	167100	7421137718	104450	
	5000296593	066000	7421268609	191170	
	5000296594	067000	7421396991	D13019	
	5000296718	088010	7421430181	104570	
	5000461058	181000	7422800385	158030	
	5000461059	181050	7422800386	158040	
	5000623050	188310	7422800391	058000	
	5000807304	040000	7423080010	158050	
	5000808166	040500	7423292490	059500	
	5000808171	141000	7423374865	D10596	
	5000808172	141500	7423398397	123020	
	5001831194	168220	7423398399	123000	
	5001832999	168260	7423398400	123010	
	5001834561	195010	7423398635	113100	
	5001834565	119450	7423467438	159520	
	5001834568	001616	7423530438	159520	
	5001835853	168140	7423530440	159500	
	5001846843	152000	7423530441	159510	
5001846844	152010	7423530442	159530		
5001846845	152040	7425982261	158030		
		7482252291	115040		
		7482252506	115000		
		7482255014	115030		
		7482266219	113020		

Index : Liste de correspondance - Codici costruttore - Referencias cruzadas

	OES	VIGNAL		OES	VIGNAL
RENAULT TRUCKS	7482285707	113030	VOLKSWAGEN	2E0 945 112 A	056550
	7482346591	115020		7CA 945 091	152180
	7482367030	115010		7CA 945 092	152180
	7482392733	198620		7CA945095	155570
	7482522006	104570		7CA945096	155580
	7482586940	198740			
	7484185589	D14161	VOLVO TRUCKS	20537280	052000
	7484538758	193020		20717520	102200
	7484585204	158040		20721495	196010
	7484585206	158050		20734485	193020
	7484585208	158030		20745060	052500
	7485118470	152170		20745066	001726
	7700353021	196020		20745225	195010
	7700377130	D14590		20745227	001616
	7700377208	198510		20769775	159010
	8200602314	D14593		20769776	159020
	265100848R	196010		20769777	159030
	265500292R	152180		20769781	152880
	265504514R	152180		20769782	152880
	265550674R	152180		20769783	152190
	265551402R	152180		20769784	152200
				20789440	198620
SCANIA	1350343	067500		20802418	059000
	1365963	168350		20872890	D12111
	1365964	168360		21087346	207010
	1756751	156780		21087347	207020
	1756754	156770		21214524	114020
	1784669	056540		21214534	114000
	1784670	056550		21341202	119550
	1791369	156790		21346521	111020
	2020496	D10596		21346522	111030
	2021575	156780		21368779	116050
	2021576	156790		21368781	116060
	2021578	155020		21368782	116030
	2021579	156770		21368783	116020
	2129985	156770		21396991	D13019
	2129986	155020		21448885	107040
	2129987	156780		21478751	107050
	2129988	156790		21735299	159530
	2129991	056550		21735301	159520
	2129992	056540		23354972	158030
	2160127	155090		23354973	158040
	2160128	155080		23354974	158050
	2340796	155520		23522304	159520
	2862201	D14852		23522305	159530
				23522307	159500
				23522308	159510
SCHMITZ	1302341	161000		23690764	159520
	1302342	161010		23690765	159530
	1348566	D14488		23690769	159500
	1364736	161000		23742314	212730
	1364737	161010		24080598	113110
	1370066	161280		82114500	107010
	1370067	161290		82114502	107050
	1415545	213010		82114504	107040
	1415546	213090		82114506	107000
				82116545	207000
UD TRUCKS	84655961	120000		82150539	114010
	261319Z01B	153860		82151157	111000
	261319Z01C	153870		82151205	111010
	261319Z01D	153880		82202076	113000
	265109Z00A	196010		82278930	112010
	265509Z00A	052500		82278938	112000
				82348508	116040
VOLKSWAGEN	2E0 945 095 A	156340		82349220	116010
	2E0 945 096 A	156350		82349221	116000
	2E0 945 111 A	056540			

Index : Liste de correspondance - Codici costruttore - Referencias cruzadas

	OES	VIGNAL	
VOLVO TRUCKS	82355678	107000	
	82355684	107010	
	82467736	107500	
	82467737	107510	
	82483073	159510	
	82483074	159500	
	82849894	158030	
	82849905	058000	
	82849923	158050	
	82849925	158040	
	84044658	198740	
	84122332	059500	
	84139927	107000	
	84139939	107010	
	84185589	D14161	
	84195505	158030	
	84195519	158040	
	84195521	158050	
	84441759	159500	
	84441760	159510	
	84441766	158030	
	84441767	158040	
	84441768	158050	
	84441936	159520	
	84441937	159530	
	84538758	193020	
	85105029	001766	
	VOLVO BUS	20480486	198650
		70364301	198640
	VOLVO CONSTRUCTION	11170068	198520
23374865		D10596	

Index références - Indice riferimenti - Índice referencias

000086	158, 178	104180	170	116060	103	154220	41, 136
000176	152, 178	104210	165	116200	57	155020	91, 131
001616	107, 157	104220	165	117000	22, 156	155080	91, 131
001619	154, 156	104250	165	117010	22, 156	155090	91, 131
001696	161, 166, 168, 171	104260	165	119450	157	155100	20, 126
001716	161, 166, 168, 171	104290	160	119470	157	155110	20, 126
001726	162, 168, 215	104300	160	119550	157	155120	20, 126
001766	104, 167	104310	160	119920	154	155130	20, 126
001786	268	104330	170	119930	154	155140	20, 126
001796	268	104340	170	120000	156	155150	20, 126
001806	268	104360	170	123000	65	155450	35, 128
001826	271	104450	160	123010	65	155460	35, 128
001830	242	104520	160	123020	65	155470	35, 128
001846	18	104570	160	141000	146	155480	35, 128
001872	129, 242	104640	165	141500	146	155490	35, 128
001916	168	104650	165	151236	271	155500	35, 128
002100	115	104670	165	152000	77, 81	155520	91, 131
014580	154	104680	170	152010	77	155540	35, 128
040000	146	104690	160	152020	73, 78, 82	155550	52, 129
040500	146	104700	165	152030	78	155560	52, 129
052000	137	104710	170	152040	77	155570	100, 127
052500	137, 138, 139	104720	160	152050	77	155580	100, 127
053700	140, 141	104760	165	152060	78	155590	55
053710	140, 141	104770	165	152070	78	155600	55
053730	136	104840	160	152130	137	155610	55
055020	126, 127	107000	102, 105, 155	152140	137	156040	133
055030	126, 127	107010	102, 105, 155	152150	137	156050	133
055040	128	107040	102, 105, 155	152160	137	156060	133
055050	128	107050	102, 105, 155	152170	137	156070	133
056000	130	107500	105, 155	152180	137	156130	133
056010	130	107510	105, 155	152190	137	156200	52, 129
056020	132	109010	21, 156	152200	137	156210	52, 129
056030	132	110520	154	152500	73, 82	156220	52, 129
056500	129, 130	110530	154	152510	73, 82	156250	27, 49, 134
056510	129, 130	110550	154	152520	73, 82	156260	27, 49, 134
056540	131, 132	110560	154	152600	81	156290	130
056550	131, 132	111000	101, 155	152880	77, 81, 107	156300	45, 130
056700	133	111010	101, 155	153000	140	156310	45, 130
056710	133	111020	101, 155	153010	140	156340	56, 100, 132
056720	134	111030	101, 155	153020	140	156350	56, 100, 132
056730	134	112000	102	153030	140	156380	49, 134
058000	118	112010	102	153040	140	156390	49, 134
059000	135	112110	177	153050	140	156540	18, 130
059500	119	112120	177	153060	140	156550	18, 130
060000	116, 117	112130	177	153070	140	156590	132
060010	116, 117	112710	177	153120	137	156600	132
066000	145	112720	177	153130	140	156630	133
067000	142	113000	104	153160	18	156640	133
067500	141, 142, 143, 144	113020	66	153170	18	156770	91, 131
067600	145	113030	66	153200	36, 139	156780	91, 131
067610	145	113100	65	153210	36, 139	156790	91, 131
080026	164	113110	104	153220	36, 139	158030	63, 101, 118
080046	164	114000	102	153230	36, 139	158040	63, 101, 118
087020	163	114010	102	153240	36, 139	158050	63, 101, 118
087030	172	114020	102	153250	36, 139	159010	64, 67, 71, 106, 135
087040	158, 169	115000	66	153260	36, 139	159020	64, 67, 71, 106, 135
088010	178	115010	66	153270	138	159030	64, 67, 71, 106, 135
094016	167	115020	66	153280	138	159500	64, 76, 105, 119
094036	161	115030	66	153660	141	159510	64, 76, 105, 119
094056	171	115040	66	153670	141	159520	64, 76, 105, 119
102200	162, 215	116000	103	153700	141	159530	64, 76, 105, 119
104090	113, 115, 165	116010	103	153710	141	160080	34, 116
104100	113, 115, 165	116020	103	153880	98	160090	34, 116
104130	160	116030	103	153890	98	160100	34, 116
104140	160	116040	103	154200	41, 136	160110	34, 116
104170	170	116050	103	154210	41, 136	160120	34, 116

Index références - Indice riferimenti - Índice referencias

160130	34, 116	168590	39, 42, 143	196010	152	280059	268
160140	34, 116	168600	38, 39, 40, 42, 143	196020	152	280099	268
160150	34, 116	168610	38, 39, 40, 143	196170	152	280109	268
160400	56, 117	168770	145	198510	166	280139	268
160410	56, 117	168780	145	198520	166	280149	268
161000	112	168790	145	198530	166	300000	47, 215
161010	112	168800	145	198540	166	300010	47, 215
161120	112	168810	144	198580	166	610080	177
161130	112	168830	145	198620	65, 104, 167	611010	177
161180	112	168890	21	198640	109, 171	611020	177
161190	112	169000	68, 72, 77	198650	75, 109, 166	611070	255
161200	112	169010	68, 72, 77	198660	161	611080	255
161210	112	169020	68, 72	198690	161	611110	255
161260	112	169030	68, 72	198740	65, 104, 167	611140	255
161270	112	169060	69, 73	198760	36, 166	611150	255
161280	112	169070	69, 73	198810	166	611500	254
161290	112	169160	21, 53, 142	199000	150	611510	254
161420	112	169170	21, 53, 142	199020	150	611520	254
161430	112	169180	53, 142	199030	150	611530	254
161460	112	169190	53, 142	199040	113, 115, 150	611540	254
161470	112	169310	67, 71	207000	103, 106	611550	254
161500	112	169320	67, 71	207010	103, 106	611560	257
161510	112	169380	21	207020	103, 106	611570	257
161560	112	169390	37, 143	211000	220	611580	254
161570	112	169400	37, 143	212010	56, 220	611590	254
161580	112	169410	37, 143	212020	52, 220	630100	241
161590	112	169420	37, 143	212030	52, 221	630110	241
161700	113	175020	265	212120	220	630120	241
161710	113	175086	265	212160	220	1987860	57
161720	113	175096	265	212170	221	A10060	256
161730	113	177136	265	212400	220	A10061	256
163010	122	180010	164	212420	26, 55, 56, 220	A10062	257
163050	122	180040	164	212460	220	A10064	256
164000	17, 120	181000	178	212470	221	A10065	257
164010	17, 48, 120	181050	158	212520	220	A10066	257
164020	97, 120	185020	69, 85	212560	220	A10779	270
164030	97, 120	185040	69	212570	221	A11212	274
164050	48	185160	69	212710	220	A14366	273
165020	17, 48, 120, 195	187120	163	212730	220	A14420	121
165030	17, 48, 120, 195	187130	172	212740	220	A15153	275
165040	31, 97, 120, 195	187140	158, 169	212750	221	D10132	271
165050	31, 97, 120, 195	187720	163	213010	14, 59, 93, 114	D10227	152
166000	145	187730	172	213070	51, 59, 114	D10493	166
166100	145	187760	158, 169	213090	14, 93, 114	D10494	166
167000	142	188010	178	213150	14, 51, 59, 114	D10495	166
167100	142	188110	178	213160	114	D10496	166
167500	142	188210	178	213200	114	D10497	166
167530	145	188310	178	213240	114	D10498	166
167550	145	188610	178	213300	114	D10499	171
167600	142	188710	178	213380	114	D10500	161
167630	21	191170	79	213430	114	D10502	152
167640	21	193020	168	221000	219	D10503	177
168010	21, 144	193170	168	221100	219	D10504	264
168020	21, 144	193200	162	221200	219	D10505	264
168090	54, 141	193280	168	221300	219	D10508	264
168100	24, 54, 141	193290	168	221500	219	D10510	264
168140	72	193360	168	240346	184	D10513	265
168220	68, 72, 89	194010	167	240356	184	D10514	265
168260	68, 72, 89	194020	167	240366	184	D10515	265
168270	142	194030	167	241346	184	D10517	271
168340	142	194130	161	241356	184	D10518	271
168350	92	194150	161	241366	184	D10519	271
168360	92	194250	171	280009	152, 268	D10596	184
168390	24	195010	162	280019	268	D10597	257
168480	38, 143	195030	162	280029	268	D10642	177
168490	54	195060	172	280049	267	D10643	177

Index références - Indice riferimenti - Índice referencias

D10800	177	D13713	166	D14427	174	D14555	186
D10873	254	D13725	266	D14428	174	D14556	186
D10874	254	D13726	266	D14429	174	D14567	216
D11147	177, 270	D13807	241	D14430	174	D14568	216
D11268	270	D13808	241	D14431	174	D14569	216
D11399	161	D13810	241	D14432	174	D14574	255
D11400	171	D13816	124	D14434	262	D14575	255
D11479	42, 148	D13817	123	D14435	262	D14576	257
D11480	42, 148	D13874	151	D14436	262	D14577	256
D11481	42, 148	D13875	174	D14437	262	D14578	256
D11482	42, 148	D13876	261, 268	D14451	227	D14587	184
D11487	256	D13878	260	D14452	227	D14588	184
D11578	256	D13879	261	D14453	227	D14589	184
D11626	267	D13880	261, 269	D14467	229	D14590	83, 184
D11627	267	D13889	256	D14468	229	D14591	184
D11628	267	D14030	174	D14469	229	D14592	184
D11689	267	D14031	174	D14470	229	D14593	83, 184
D11809	260, 266	D14034	174	D14471	229	D14594	184
D11865	266	D14035	174	D14477	229	D14595	184
D11868	260, 266	D14037	134, 175	D14478	229	D14596	184
D11888	152	D14038	134, 175	D14479	229	D14598	216
D11889	265	D14039	134, 175	D14480	229	D14655	174
D11899	177	D14040	134, 175	D14482	225	D14685	250
D12334	41, 148	D14063	244	D14483	225	D14689	256
D12335	41, 148	D14116	151	D14484	225	D14706	182
D12336	41, 148	D14148	247	D14485	225	D14707	182
D12337	41, 148	D14165	212	D14486	225	D14708	182
D12338	42	D14166	213	D14487	223	D14709	182
D12339	42	D14170	160, 262	D14488	223	D14710	182
D12340	42	D14188	124	D14489	223	D14711	182
D12341	42	D14189	124	D14490	223	D14712	182
D12428	176	D14190	238	D14491	223	D14713	182
D12429	176	D14191	199	D14492	223	D14714	181
D12430	141, 176	D14195	244	D14493	223	D14715	181
D12449	267	D14208	261, 269	D14494	223	D14716	181
D12450	267	D14214	261	D14495	223	D14721	266
D12699	165	D14249	202	D14496	223	D14722	96, 165
D12711	134, 176	D14311	257	D14500	222	D14724	222
D12712	134, 176	D14312	255	D14501	222	D14725	222
D12713	180	D14313	255	D14502	222	D14726	222
D12714	180	D14314	255	D14503	222	D14732	225
D12715	180	D14315	256	D14507	224	D14733	225
D12867	166	D14316	255	D14508	224	D14734	225
D12953	135, 143, 242	D14320	110, 207	D14509	224	D14735	225
D13019	108	D14321	110, 207	D14510	224	D14736	225
D13034	134, 176	D14322	110, 207	D14511	230	D14737	226
D13035	134, 176	D14323	110, 207	D14512	230	D14738	226
D13205	180	D14324	206	D14513	230	D14739	226
D13206	180	D14325	206	D14514	230	D14740	226
D13207	180	D14326	244	D14515	230	D14741	226
D13254	264	D14327	247	D14517	152	D14742	226
D13255	264	D14331	261	D14529	184	D14743	198
D13256	264	D14345	124	D14530	184	D14744	198
D13257	264	D14348	124	D14531	184	D14745	198
D13260	264	D14352	262	D14535	182	D14746	227
D13262	265	D14353	238	D14536	182	D14747	222
D13263	264	D14354	238	D14537	252	D14752	223
D13277	177	D14357	202	D14538	251	D14753	223
D13288	137	D14358	202	D14539	251	D14754	223
D13609	151	D14362	261	D14540	196	D14755	223
D13610	151	D14421	174	D14542	196	D14756	222
D13620	247, 248, 250	D14422	174	D14544	196	D14757	222
D13621	247, 248, 250	D14423	174	D14547	197	D14758	222
D13622	247, 248, 250	D14424	174	D14549	197	D14760	234
D13624	176	D14425	113, 115, 174	D14552	197	D14762	234
D13710	161	D14426	113, 115, 174	D14553	197	D14779	223

Index références - Indice riferimenti - Índice referencias

D14780	264	D16025	147	D16130	249
D14781	113, 175	D16026	183	D16131	248
D14782	113, 175	D16027	183	D16132	248
D14802	256	D16028	228	D16133	250
D14811	60	D16029	125	D16134	250
D14824	256	D16030	217	D16135	250
D14846	115, 266	D16031	183	D16150	224
D14847	115, 266	D16032	183	D16151	224
D14850	188	D16033	246	D16152	224
D14851	188	D16034	236	D16153	224
D14852	189	D16035	232	D16155	187
D14855	189	D16036	252	D16156	187
D14856	189	D16038	239	D16157	187
D14857	186	D16039	239	D16160	203
D14879	165	D16040	211	D16161	224
D14880	186	D16041	211	D16162	252
D14885	266	D16042	200	D16163	251
D14922	235	D16043	247	D23301	232
D14925	234	D16044	244	D23354	232
D14926	234	D16045	244	D23363	232
D14928	235	D16046	244	D23401	232
D14929	235	D16047	210	D23501	232
D14930	235	D16048	210	D23513	232
D14931	235	D16049	210	R12486	262
D14932	235	D16050	210	R12499	265
D14933	235	D16051	211	R12575	267
D14934	235	D16052	211	R12576	267
D14935	235	D16053	211	R14173	269
D14963	205	D16055	244	R14338	97, 270
D14964	205	D16056	238	R14339	97, 270
D14965	192	D16058	232	R14364	151
D14966	192	D16067	213	R14407	265
D14967	193	D16068	213	R14412	113, 115, 270
D14968	190	D16069	172	R14413	113, 115, 262, 270
D14980	115, 266	D16070	172	R14416	270
D14983	115, 266	D16071	172	R14418	113, 115, 269
D14984	115, 260, 266	D16072	172	R14426	113, 115, 269
D14985	269	D16073	172	STA	242
D14989	235	D16074	241		
D14990	182	D16075	238		
D14991	182	D16076	238		
D14994	199	D16077	213		
D15048	199	D16086	180		
D15056	122	D16087	180		
D15077	190	D16088	180		
D15093	192	D16089	125		
D15094	193	D16093	217		
D15095	193	D16099	258		
D15100	194	D16100	258		
D15155	262	D16103	180		
D16001	236	D16104	180		
D16003	236	D16105	180		
D16004	238	D16108	147		
D16005	238	D16109	147		
D16006	123	D16110	189		
D16007	258	D16111	187		
D16008	183	D16114	191		
D16009	183	D16115	208		
D16010	217	D16118	202		
D16011	123	D16119	191		
D16012	228	D16120	191		
D16017	238	D16122	212		
D16018	238	D16123	212		
D16022	203	D16124	194		
D16023	203	D16126	244		
D16024	147	D16129	249		

N° d'homologation - Numero di omologazione - Número de homologación

E2	781	FE80	164	E20	0021276	STOP	125
E2	1295	SMD00	167	E1	003244	R104	180
E2	2040	LC8	128	E2	0050	C199	154
E13	2060	725	148	E11	010002	R70	182
E2	2065	SMD98	171	E24	020078	FE12	177
E3	2617	2751	152	E20	020889	DX	176
E1	3110	F930	123	E2	04010	SMD98	161
E4	4052	FRR	124	E2	04075	LC9	135
E2	4054	FPL93	168	E2	05010	FE04	160
E2	4089	FE94	161	E2	05011	FE04	170
E2	4091	FE94	171	E2	05021	SMD04	165
E2	4093	FE94	167	E2	05022	SMD04	160
E2	4701	FE87	169	E2	05023	SMD04	170
E2	4703	FE87	158	E2	06018	C105	154
E2	5047	ICDL94	157	E2	06024	LC5T	140
E2	5052	FE95	162	E2	07092	DXLC8	176
E2	5126	FE95	172	E2	08028	SRD07	155
E9	6653	FRR	124	E2	09025	ICDL07	156
E2	7001	EPP96	152	E20	1390	W97	172
E2	7001	EPP98	152	E20	1397	W97	172
E2	7102	FE02	162	E20	1398	W97	172
E2	7139	ICDL94	157	E2	21003	LC15	136
E11	7573	2963	186				
E2	8005	LC5	137				
E2	8040	SMD98	166				
E13	8434	725	148				
E2	9056	LC7T	145				
E2	10035	DX	177				
E2	10073	SRD08	155				
E2	10113	LC9 LED	118				
E13	10989	BX868	151				
E2	11017	EPP96 LED	151				
E2	11128	ICDL10	156				
E9	11734	SLIM	148				
E2	12007	LC8	126				
E2	12056	C105	154				
E2	12164	LC10 LED	119				
E4	13992	FRR	124				
E2	14010	FA3 LED	174				
E2	14085	LC11	116				
E2	14086	LC11	116				
E9	14260	SESA AIRGLOW	123				
E9	14261	SESA SOLAR	122				
E2	16005	CTL15	120				
E2	16007	BL15	120				
E2	16027	LC12 LED	112				
E2	16059	ICDL15	156				
E2	16111	CTL14	148				
E2	18042	LC12 G LED	112				
E2	19014	LPL18	150				
E2	19106	LCR19	114				
E2	19140	SL1000	186				
E4	23271	FRR	124				
E2	86710	FE87	163				
E2	86711	FE87	172				
E2	88017	LC7	142				
E2	88033	LC6	145				
E2	88034	LC6	145				
E2	88035	LC7	142				
E2	88714	FE88	179				
E2	90711	FE81	158				
E2	91098	LC4	146				
E2	91099	LC4	146				
E2	91715	FE80	164				
E13	0001	R104	180				
E13	0002	R104	180				



Feux arrière - Fanali posteriore - Pilotos traseros



Index images - immagini - imágenes

Feux arrière - Fanali posteriore - Pilotos traseros

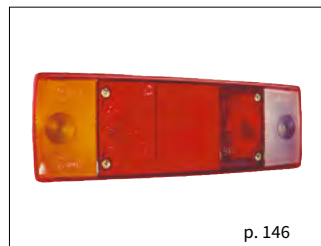
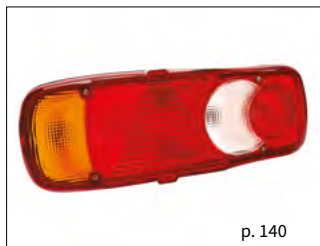

Eclaireurs de plaque - Luci targa - Iluminación de placa



Feux clignotants - Luci intermittenti - Pilotos intermitentes

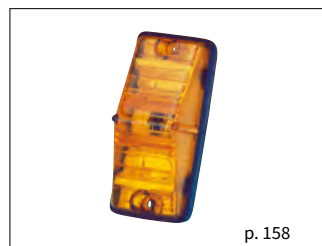
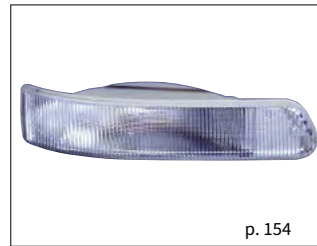
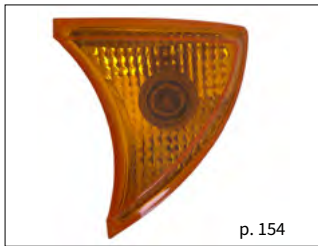

Feux de position - Luci di posizione - Pilotos de posición

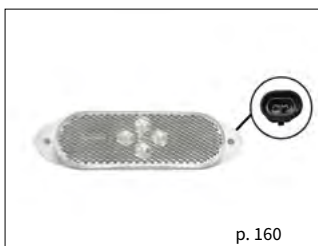

Index images - immagini - imágenes

Feux de position - Luci di posizione - Pilotos de posición

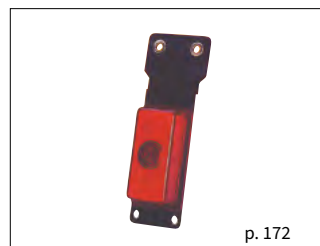
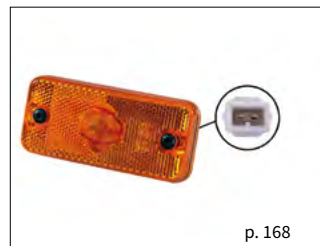
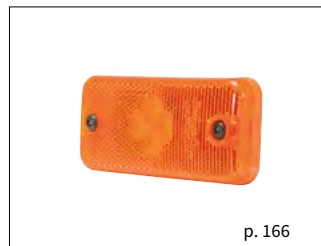
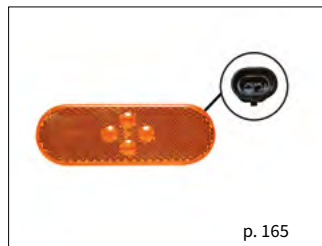

Feux de gabarits - Luci d'ingombro - Luces de anchura



Feux de gabarits - Luci d'ingombro - Luces de anchura



Signalisation passive - Segnaletica passiva - Señalización

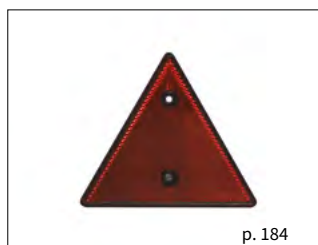
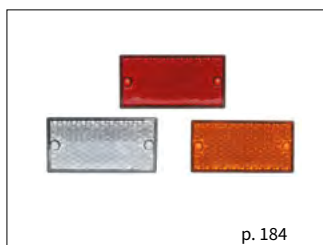
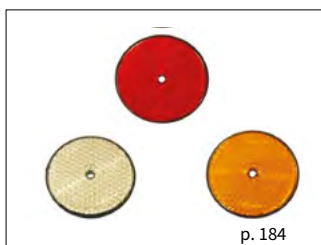
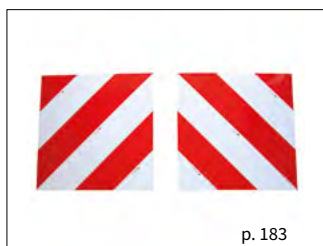
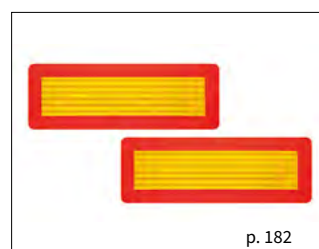
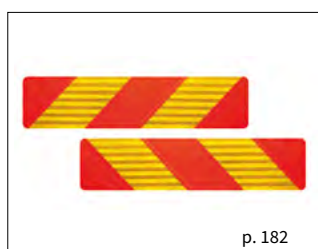
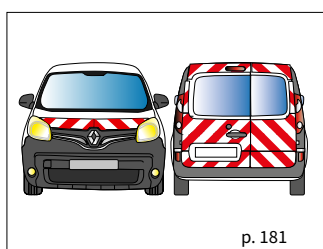
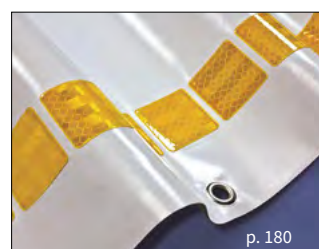
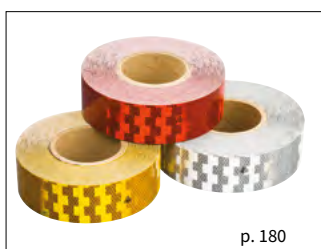

Index images - immagini - imágenes

Phares de travail - Fari da lavoro - Faros de trabajo



Éclairage de sécurité - Luci di segnalazione - Faros de advertancia



Phares de conduite - Proiettori - Faros delanteros



Feux auxiliaires - Fari ausiliari - Iluminación auxiliar

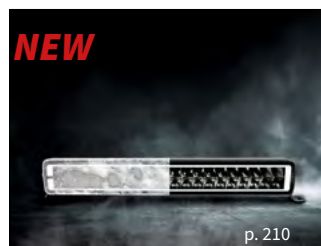

Index images - immagini - imágenes

Feux auxiliaires - Fari ausiliari - Iluminación auxiliar



Éclairage intérieur - Illuminazione interna - Iluminación interior



Gyrophares - Girofari - Luces rotativas



Gyrophares - Girofari - Luces rotativas



Index images - immagini - imágenes

Gyrophares - Girofari - Luces rotativas



Rampes lumineuses - Barre di segnalazione - Puentes luminosos

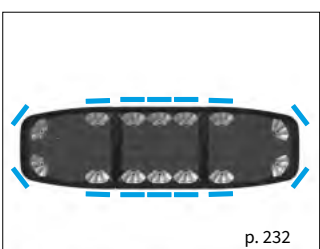
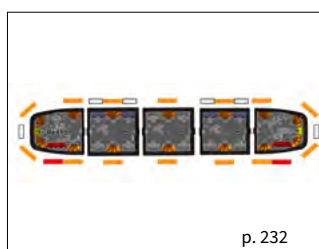
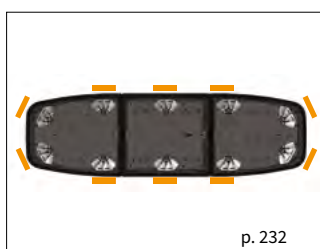

Triflash



Triflash



Feux de pénétration - Luci direzionali - Luces direccionales

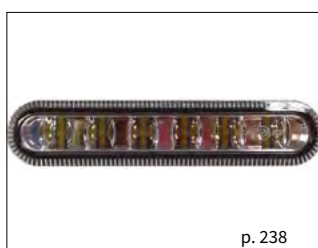

Alarmes sonores de recul - Cicalini retromarcia - Alarmas sonoras de marcha atrás



Index images - immagini - imágenes

Systemes caméras - Telecamere - Sistemas de cámara



Coffres porte extincteur - Cassonetti porta estintore - Porta extintores



Prises et câbles spiralés - Spine e spirali - Enchufes y espirales



Prises et câbles spiralés - Spine e spirali - Enchufes y espirales



Prises USB - Porte USB - Tomas USB



Connecteurs - Connettori - Conectores



Index images - immagini - imágenes

Faisceaux - Cablaggi - Cableados

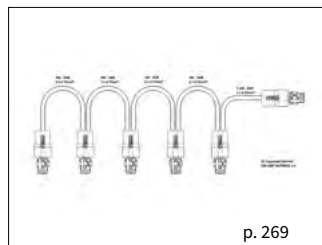
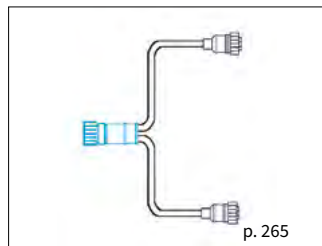
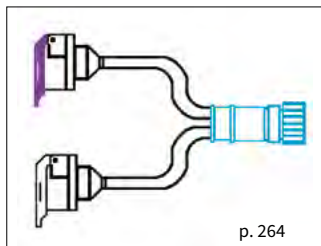

Systèmes câblage et feux - Kit cablaggi e fanali - Sistemas cableados e iluminación

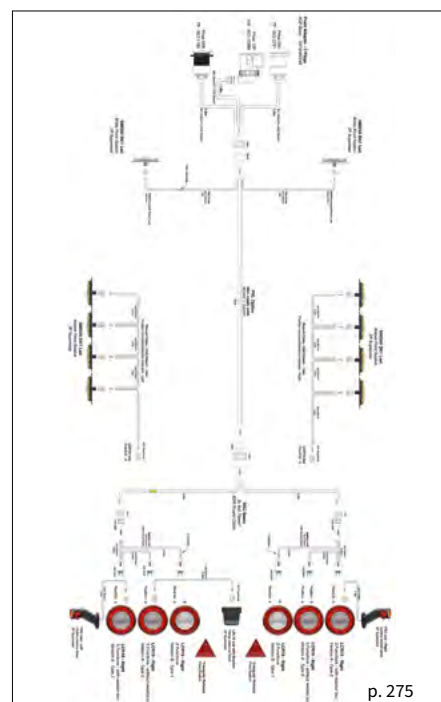
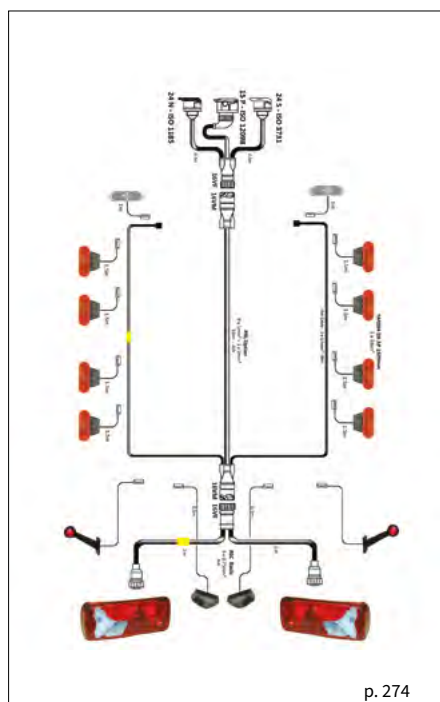
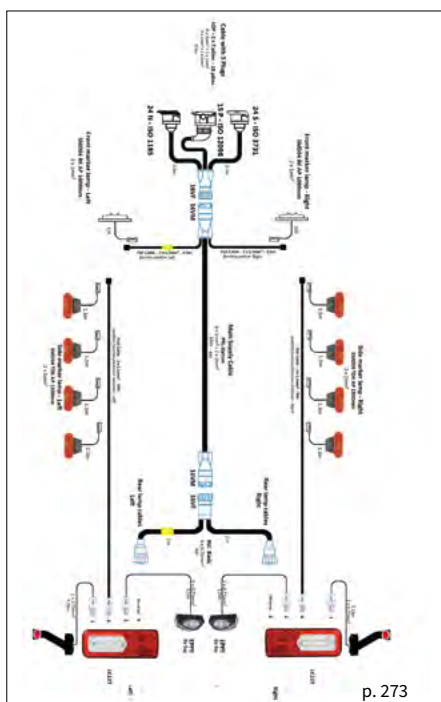

MISE EN GARDE SUR LES RISQUES JURIDIQUES DE LA CONTREFAÇON
AVVERTIMENTO SUI RISCHI LEGALI DELLA CONTRAFFAZIONE
ADVERTENCIA SOBRE LOS RIESGOS JURIDICOS DE LA FALSIFICACION

MISE EN GARDE SUR LES RISQUES JURIDIQUES DE LA CONTREFAÇON DES PIÈCES D'ORIGINE

Les **remplacements** ou **modifications** de composants autres que ceux montés et recommandés par le constructeur peuvent remettre en cause la sécurité des usagers de la route (diminution des performances photométriques).

Ex : **Le montage d'un cabochon adaptable sur un feu d'origine Vignal est interdit.**

Toute opération de ce type sur le matériel sera **à la charge entière de celui qui sera intervenu** et pourra **remettre en cause** l'homologation du véhicule délivrée par les autorités compétentes.

Le fabricant dégage sa responsabilité réglementaire.

La contrefaçon et la concurrence déloyale de pièces sont condamnées par la loi civile et pénale :

- La contrefaçon engage la responsabilité civile et pénale du fabricant, du revendeur, voire dans certains cas de l'utilisateur des pièces de contrefaçon.

- La concurrence déloyale engage la responsabilité civile du fabricant et du revendeur de copies serviles; en tirant de cette opération un avantage injustifié, **il fausse les règles normales de la concurrence** et réalise de ce fait **un acte de parasitisme** en détournant le travail de recherche et de conception, ainsi que le savoir-faire des constructeurs.

AVVERTIMENTO SUI RISCHI LEGALI DELLA CONTRAFFAZIONE DEI PRODOTTI ORIGINALI

La **sostituzione** o **modifica** di Ricambi con parti diverse da quelle assemblate e raccomandate dal costruttore può ridurre la sicurezza degli utenti della strada (riduzione delle performances fotometriche)

Es: **Il montaggio di una lente adattabile su un fanale originale Vignal è proibito.**

Qualunque operazione di questo tipo sul materiale **sarà giudicata come responsabilità di chi l'ha effettuata** e **comprometterà l'omologazione del veicolo** rilasciata dalle autorità competenti.

Il costruttore declina ogni responsabilità.

La contraffazione e la concorrenza sleale di parti originali sono soggette legalmente a condanne civili e penali:

- La contraffazione sottomette a responsabilità civile e penale il fabbricante, il rivenditore ed, in certi casi, l'utilizzatore di prodotti copiati.

- La concorrenza sleale sottomette a responsabilità civile il fabbricante e rivenditore di prodotti copiati; creando un vantaggio ingiustificato, **falsa le regole normali della concorrenza** e realizza un **atto di parasitismo** approfittando del lavoro di design, ricerca e sviluppo, così come del know-how dei fabbricanti di prodotti originali.

ADVERTENCIA SOBRE LOS RIESGOS JURIDICOS DE LA FALSIFICACION DE LOS PRODUCTOS ORIGINALES

Las **substituciones** o las **modificaciones** de Repuestos diferente que los montados y recomendados por el constructor pueden ser causa de una seguridad reducida de los usuarios de la carretera (disminución de los resultados fotométricos)

Ej: **El montaje de una tulipa adaptable sobre un piloto original Vignal está prohibido.**

Todas las operaciones de este tipo sobre el material **serán juzgadas como responsabilidad** del que habrá intervenido y **comprometerá la homologación del vehículo** emitida por las autoridades competentes.

El constructor declina todas las responsabilidades.

La falsificación y la competencia desleal de piezas son condenadas por la ley civil y penal:

- La falsificación está sujeta a responsabilidad civil y penal del fabricante, del revendedor, incluso, en ciertos casos, del utilizador de los productos copiados.

- La competencia desleal está sujeta a responsabilidad civil del fabricante y del revendedor de copias; trayendo una ventaja injustificada de esta operación, **falsea las reglas normales de la competencia** y realiza **un acto de parasitismo** aprovechándose del trabajo de I+D, así como del know-how de los constructores de productos originales.

NORMES ET RÈGLEMENTATION

NORME E RIGOLAMENTO

NORMA Y REGLAMENTO

Les extraits de réglementation sont disponibles sur notre site web.

Les éléments sont extraits du règlement ECE R48 concernant la majorité des véhicules.
Se référer au règlement pour des configurations particulières.

Les produits doivent être homologués selon le dernier amendement en vigueur
L'utilisateur est responsable de la conformité de l'équipement de son véhicule.

VIGNAL s'engage sur la conformité de ses produits.



Le sigle ADR signifie que le produit est homologué pour le montage sur des véhicules qui satisfont aux dispositions ADR (accord européen relatif au transport international des marchandises dangereuses par route).

Les produits ADR ont un indice de protection d'au moins IP54.

L'indice de protection IP détermine le degré de protection du matériel contre la pénétration des corps solides (1er chiffre) et des liquides (2ème chiffre).



Exemple : IP54

1er chiffre : 5 => Protégé contre les infiltrations de poussière

2ème chiffre : 4 => Protégé contre les projections d'eau (haute pression) de toutes les directions

I estratti di rigolamento sono disponibili sul nostro sitio web.

I elemnti sono estratti del rigolamento ECE R48 per la maggior parte dei veicoli.
Riferirsi al rigolamento per configurazione speciale.

I prodotti devono essere omologati secondo l'ultima revisione in vigore.
L'utilizzatore è risponsabile della conformità dell' attrezzatura del suo veicolo.

VIGNAL si impegna sulla conformità dei suoi prodotti.



Il siglo ADR significa che il prodotto è omologato per il montaggio sui veicoli omologati ADR (accordo europeo sul trasporto internazionale delle merce pericolose).

I prodotti ADR hanno un indice di protezione minimo IP54.

L'indice di protezione IP determina il grado di protezione contra l'ingresso di materie solide (primo numero) e liquide (secondo numero).



Esempio : IP54

Primo numero: 5 = proteggeto contra la polvere

Secondo numero: 4 = proteggeto contra l'acqua (alta pressione) da qualche direzione.

Los extractos de reglamento están disponibles en nuestro sitio web.

Los elementos son extractos del reglamento ECE R48 que concierne la mayoría de los vehículos.
Referirse al reglamento para configuraciones particulares.

Los productos tienen que ser homologados según la última enmienda en vigor.
El usuario es responsable de la conformidad del equipo de su vehículo.

VIGNAL se compromete sobre la conformidad de sus productos.



El sigla ADR significa que el producto es homologado para el montaje sobre vehículos homologados ADR (Acuerdo Europeo sobre el transporte internacional de cargas peligrosas por vía terrestre).

Los productos ADR tienen un grado de protección de al menos IP54.

El IP determina el grado de protección del material contra el ingreso de objetos sólidos (primer dígito) e agua (segundo dígito).



Ejemplo : IP54

1er dígito : 5 => Protección contra polvo

2do : 4 => Protección contra chorros de agua

NORMES ET RÈGLEMENTATION

NORME E RIGOLAMENTO

NORMA Y REGLAMENTO

Indice de protection

Indice	1 ^{er} chiffre (dizaine) = Protection contre la poussière	2 ^{ème} chiffre (unité) = Protection contre l'eau
0	Aucune protection.	Aucune protection.
1	Protégé contre les corps solides supérieurs à 50 mm.	Protégé contre les chutes verticales de gouttes d'eau.
2	Protégé contre les corps solides supérieurs à 12,5 mm.	Protégé contre les chutes de gouttes d'eau jusqu'à 15° de la verticale.
3	Protégé contre les corps solides supérieurs à 2,5 mm.	Protégé contre l'eau en pluie jusqu'à 60° de la verticale.
4	Protégé contre les corps solides supérieurs à 1 mm.	Protégé contre les projections d'eau de toutes directions.
5	Protégé contre les poussières.	Protégé contre les jets d'eau de toutes directions à la lance.
6	Totalement protégé contre les poussières.	Protégé contre les forts jets d'eau de toutes directions à la lance.
7	-	Protégé contre les effets de l'immersion (jusqu'à 1m).
8	-	Matériel submersible dans des conditions spécifiées (immersion prolongée) au delà de 1 m et pendant 30 minutes.
9K	-	Protection contre le nettoyage à haute pression.

International Protection

Livello	1 ^a cifra = Protezione contro l'accesso di corpi solidi	2 nd digit = Protezione contro l'accesso di liquidi
0	Nessuna protezione.	Non protetto.
1	Protetto contro corpi solidi di dimensioni superiori a 50mm.	Protetto da caduta verticale di gocce d'acqua.
2	Protetto contro corpi solidi di dimensioni superiori a 12mm.	Protetto da caduta di gocce d'acqua con inclinazione massima 15°.
3	Protetto contro corpi solidi di dimensioni superiori a 2.5mm.	Protetto dalla pioggia.
4	Protetto contro corpi solidi di dimensioni superiori a 1mm.	Protetto da spruzzi.
5	Protetto contro la polvere.	Protetto da getti d'acqua.
6	Totalmente protetto contro la polvere.	Protetto da ondate.
7	-	Protetto da immersione temporanea.
8	-	Protetto da immersione continua.
9K	-	Protetto da alta pressione

Grado de protección IP

Nivel	Primer dígito = Protección contra el ingreso de objetos sólidos	Segundo dígito = Protección contra el ingreso de agua
0	Sin protección.	Sin protección.
1	Protección contra los objetos sólidos mayores de 50 mm.	Protección contra goteos de agua.
2	Protección contra los objetos sólidos mayores de 12,5 mm.	Protección contra goteos de agua (inclinado 15°).
3	Protección contra los objetos sólidos mayores de 2,5 mm.	Protección contra agua nebulizada (spray).
4	Protección contra los objetos sólidos mayores de 1,0 mm.	Protección contra proyecciones de agua de toda dirección.
5	Protección contra polvo.	Protección contra chorros de agua.
6	Protección fuerte contra polvo.	Protección contra fuertes chorros de agua.
7	-	Inmersión completa en agua.
8	-	Inmersión completa y continua en agua.
9K	-	Protección contra la limpieza de alta presión.



2024



VIGNAL GROUP

19, avenue du 24 Août 1944
69960 Corbas - France
E-mail : contact@vignal-group.com
Site web : www.vignal-group.com

VIGNAL SYSTEMS
19, avenue du 24 Août 1944
69960 Corbas - France

VIGNAL ABL
3, rue de la Cotonnière
Z.I. du Chemin Vert
14000 Caen - France

VIGNAL C.E.A.
11, Via Alla Rossa
6862 Rancate - Switzerland

VIGNAL ABL USA
660 Golf Club Boulevard
Mosinee, WI 54455
United States

VIGNAL SESALY
12 avenue de l'Industrie*
69960 Corbas - France
* en 2024

VIGNAL SARR
170 avenue du Panorama
72100 Le Mans - France

VIGNAL CHANGZHOU
Building B2, Huaping (Changzhou)
Intelligent Manufacturing Park,
585 Huanghe West Road,
Xinbei District Changzhou
Jiangsu Province, China



Ref: 99999CA

Imprimé en France - Novembre 2023